

6.0 JET ENGINE WAKE AND NOISE DATA

6.1 Jet Engine Exhaust Velocities and Temperatures

6.2 Airport and Community Noise

- NOTES:
- JT3D ENGINE
 - DATA NOT VERIFIED BY TEST
 - CONDITIONS:
 - STANDARD DAY
 - SEA LEVEL
 - ZERO WIND
 - STATIC AIRPLANE

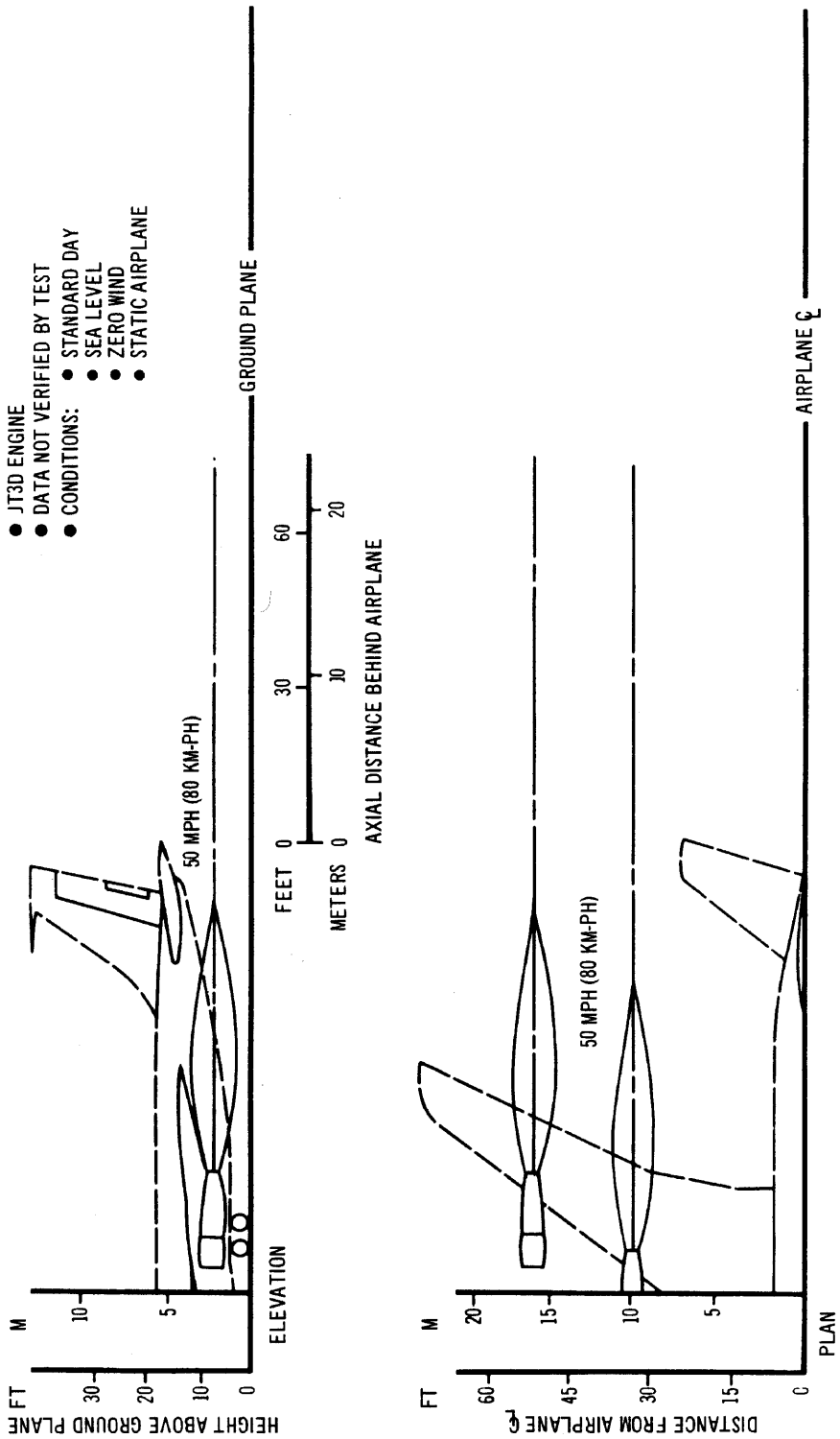

6.1 JET ENGINE EXHAUST - VELOCITY CONTOURS - IDLE POWER
 MODELS 707-120B, -320B, -320C

**JET ENGINE EXHAUST - TEMPERATURE CONTOURS - IDLE POWER
 MODELS 707-120B, -320B, -320C**

- NOTES:**
- JT3D ENGINE
 - DATA NOT VERIFIED BY TEST
 - CONDITIONS:
 - STANDARD DAY
 - SEA LEVEL
 - ZERO WIND
 - STATIC AIRPLANE

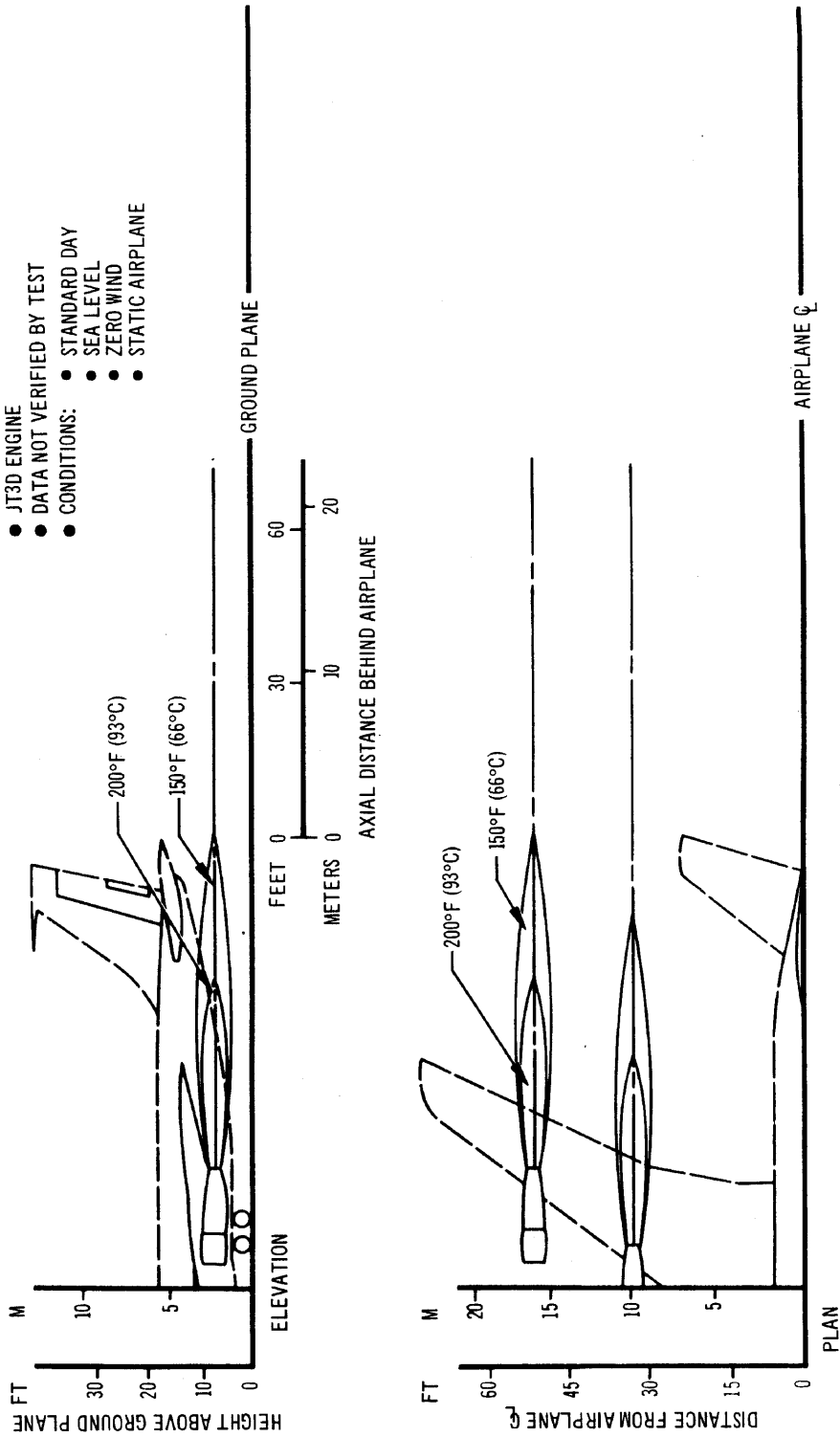

- NOTES:
- JT3D ENGINE
 - DATA NOT VERIFIED BY TEST
 - STANDARD DAY
 - SEA LEVEL
 - ZERO WIND
 - STATIC AIRPLANE TO LEVEL
 - STRAIGHT AHEAD MOVEMENT

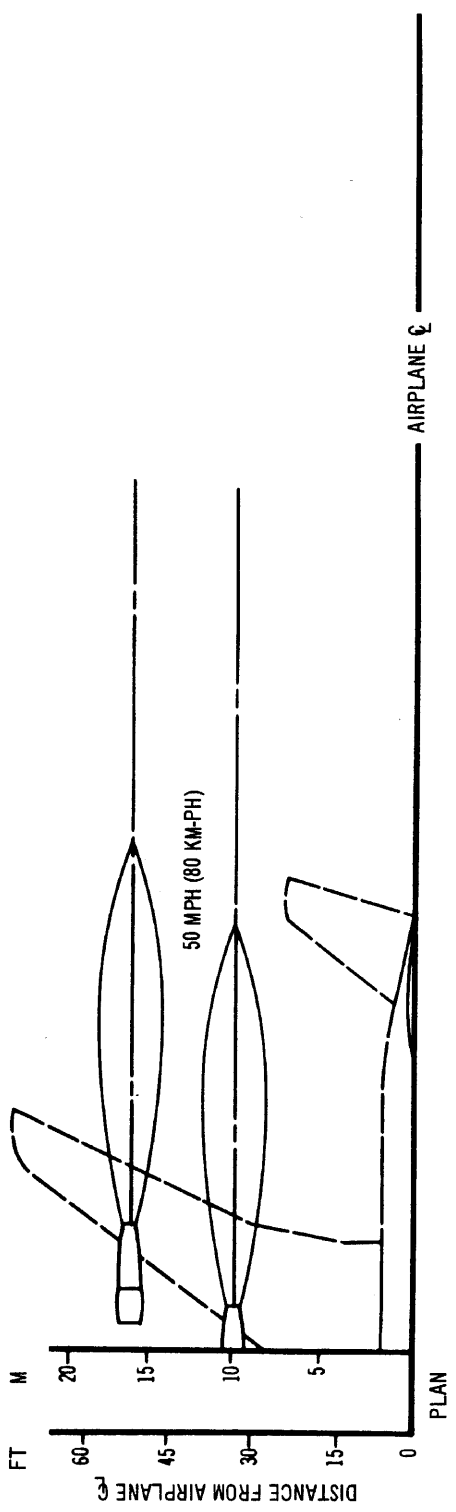
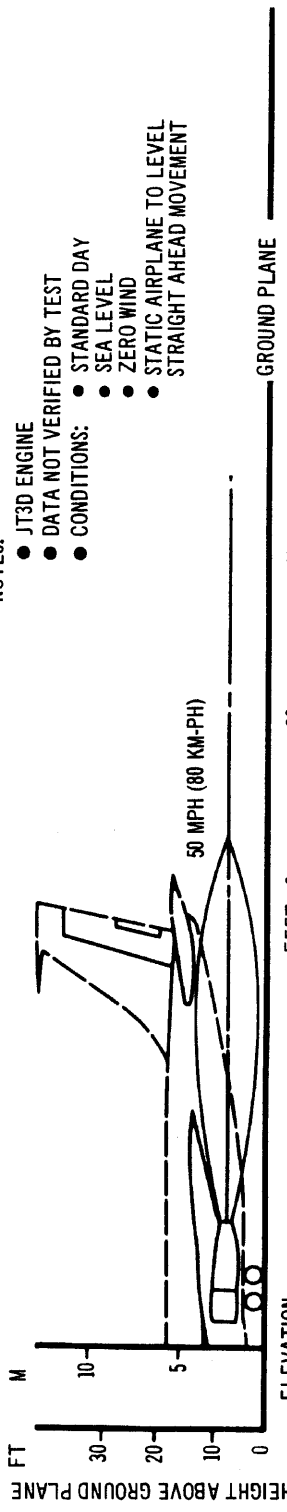

**JET ENGINE EXHAUST - VELOCITY CONTOURS - BREAKAWAY POWER
MODELS 707-120B, -320B, -320C**

JET ENGINE EXHAUST - TEMPERATURE CONTOURS - BREAKAWAY POWER MODELS 707-120B, -320B, -320C

- NOTES:**
- JT3D ENGINE
 - DATA NOT VERIFIED BY TEST
 - CONDITIONS:
 - STANDARD DAY
 - SEA LEVEL
 - ZERO WIND
 - STATIC AIRPLANE TO LEVEL STRAIGHT AHEAD MOVEMENT

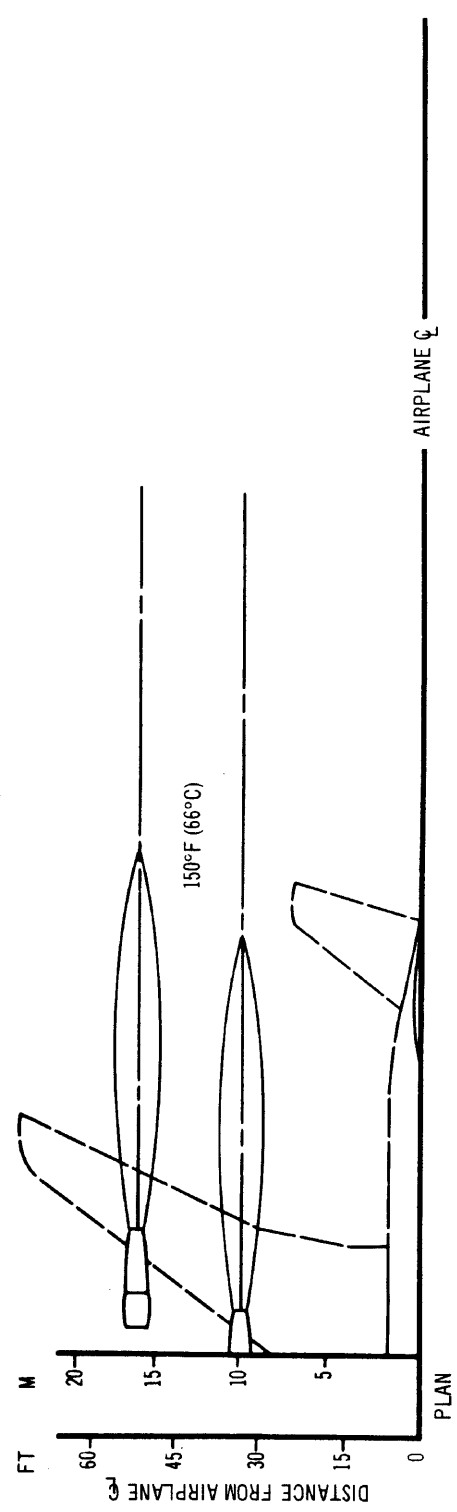
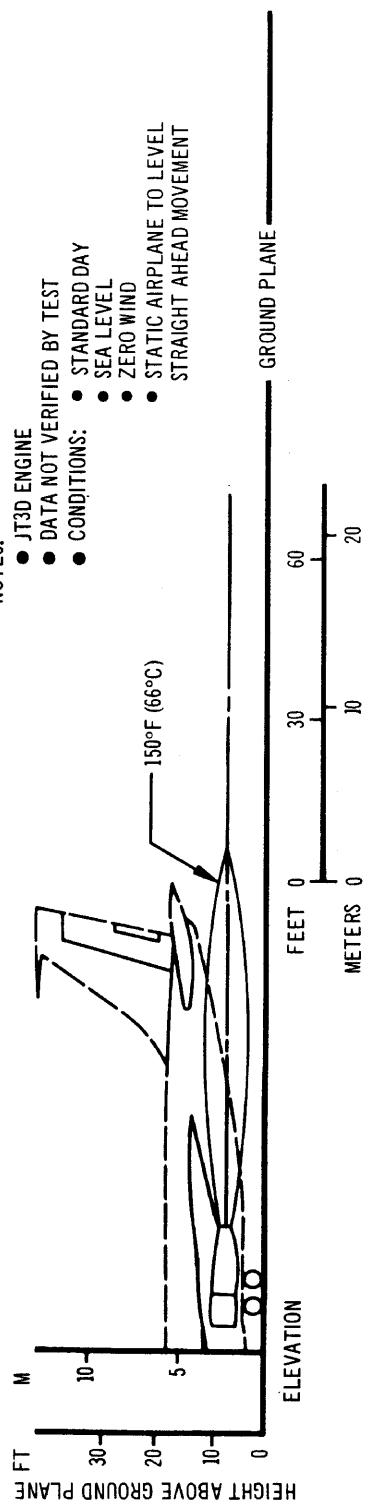

NOTES:

- JT3D ENGINE
- DATA NOT VERIFIED BY TEST
- CONDITIONS:
 - STANDARD DAY
 - SEA LEVEL
 - ZERO WIND
 - STATIC AIRPLANE

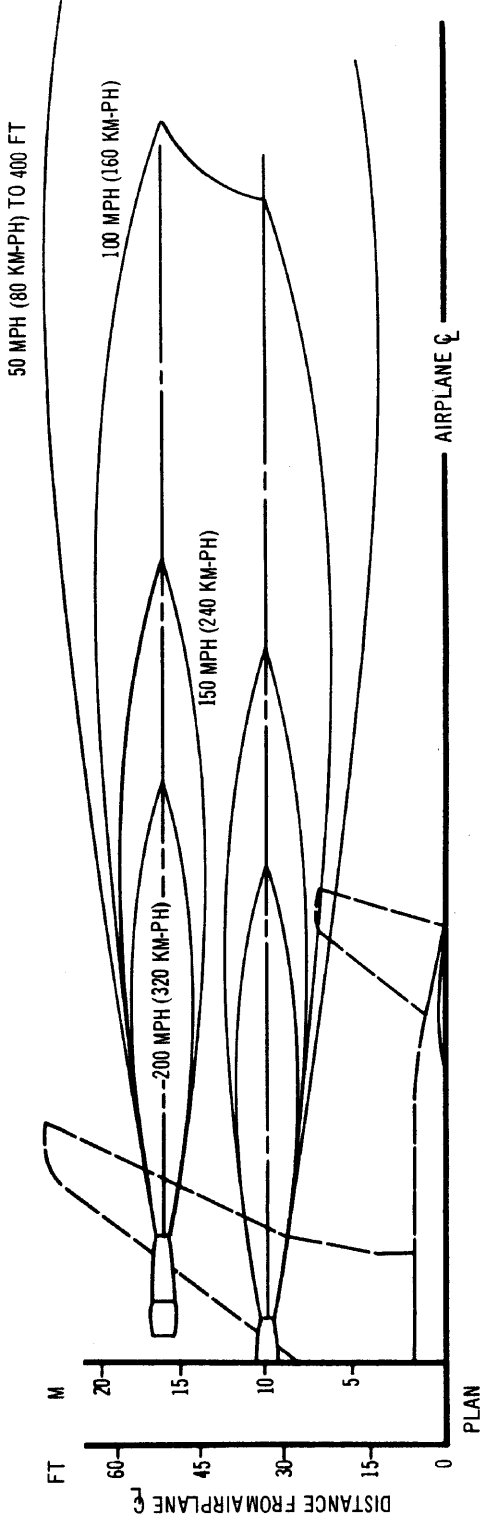
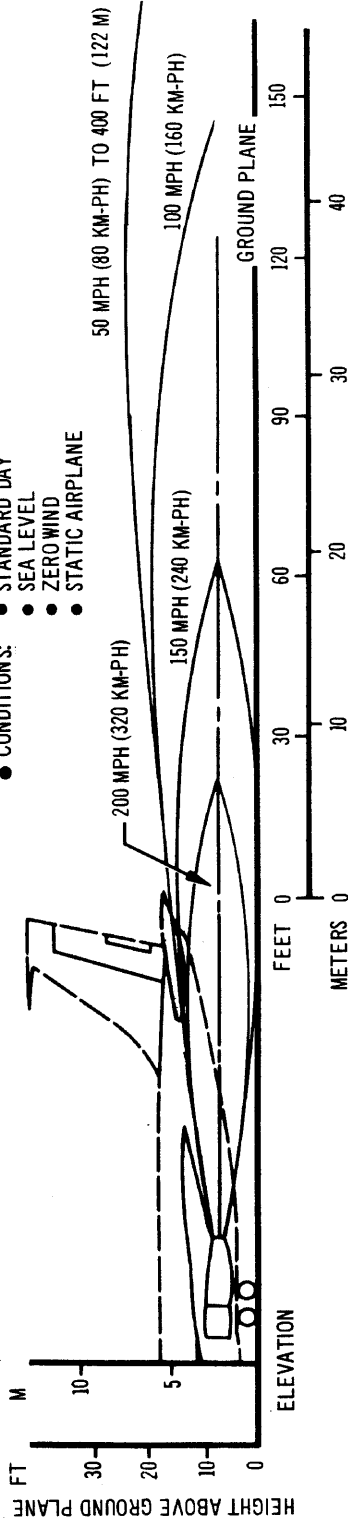

JET ENGINE EXHAUST - VELOCITY CONTOURS - MAXIMUM POWER
 MODELS 707-120B, -320B, -320C

- NOTES:
- JT3D ENGINE
 - DATA NOT VERIFIED BY TEST
 - CONDITIONS:
 - STANDARD DAY
 - SEA LEVEL
 - ZERO WIND
 - STATIC AIRPLANE

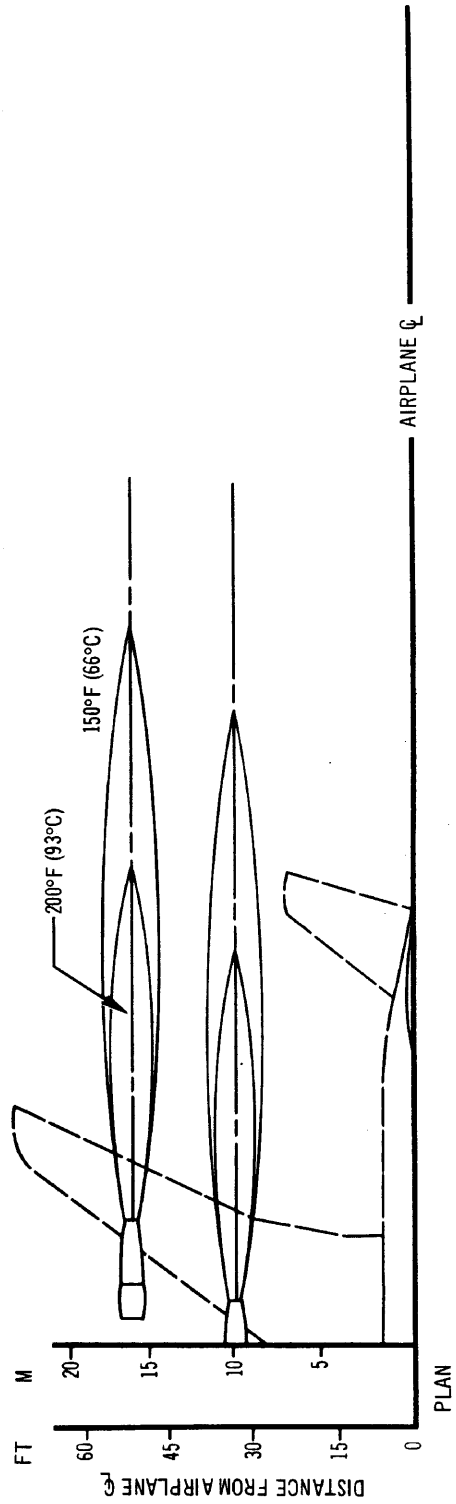
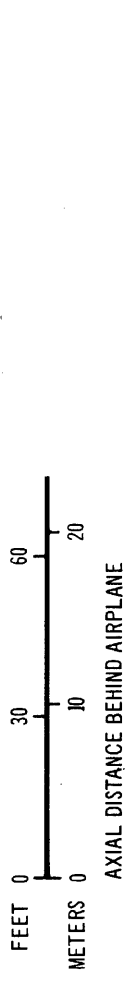
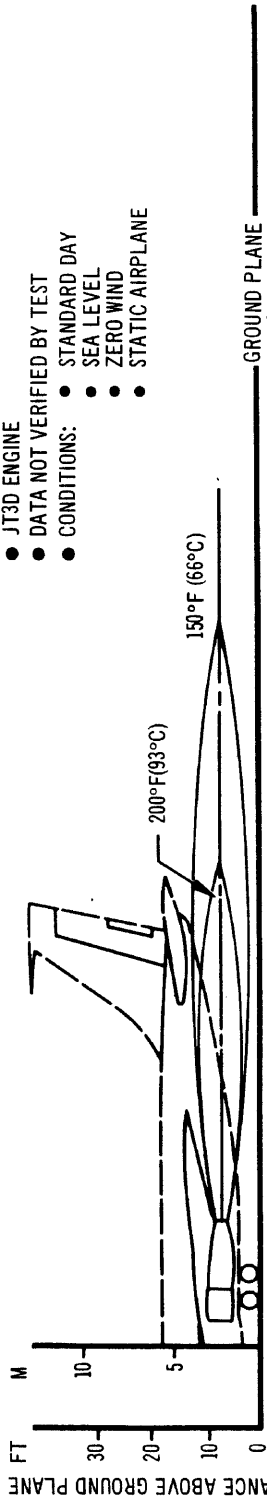

JET ENGINE EXHAUST - TEMPERATURE CONTOURS - MAXIMUM POWER
 MODELS 707-120B, -320B, -320C

- NOTES:
- JT4A ENGINE
 - DATA NOT VERIFIED BY TEST
 - CONDITIONS:
 - STANDARD DAY
 - SEA LEVEL
 - ZERO WIND
 - STATIC AIRPLANE

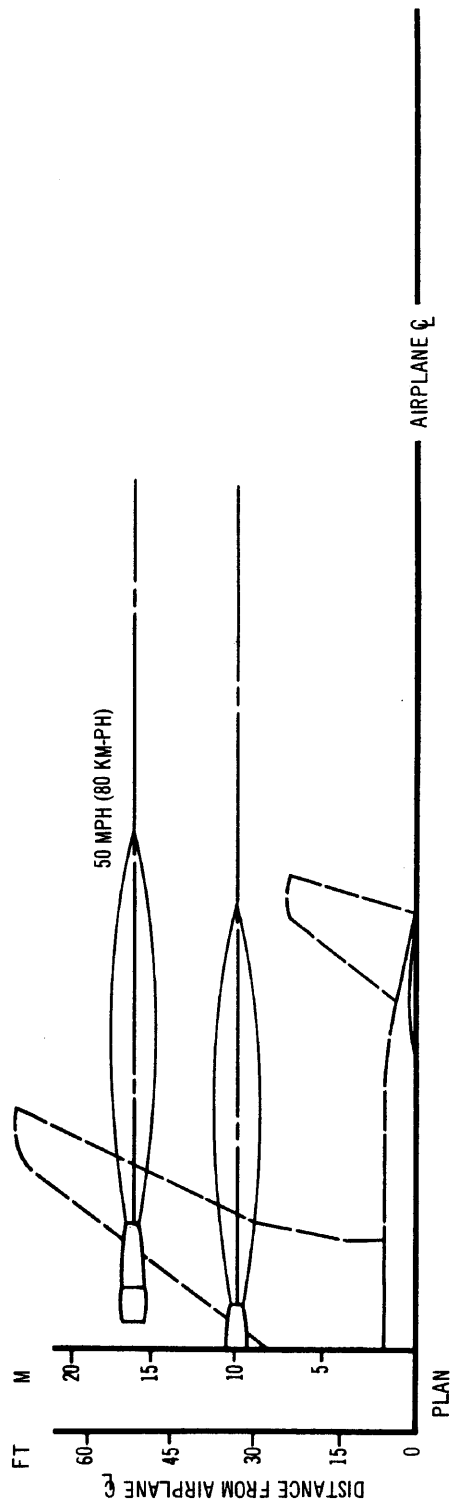
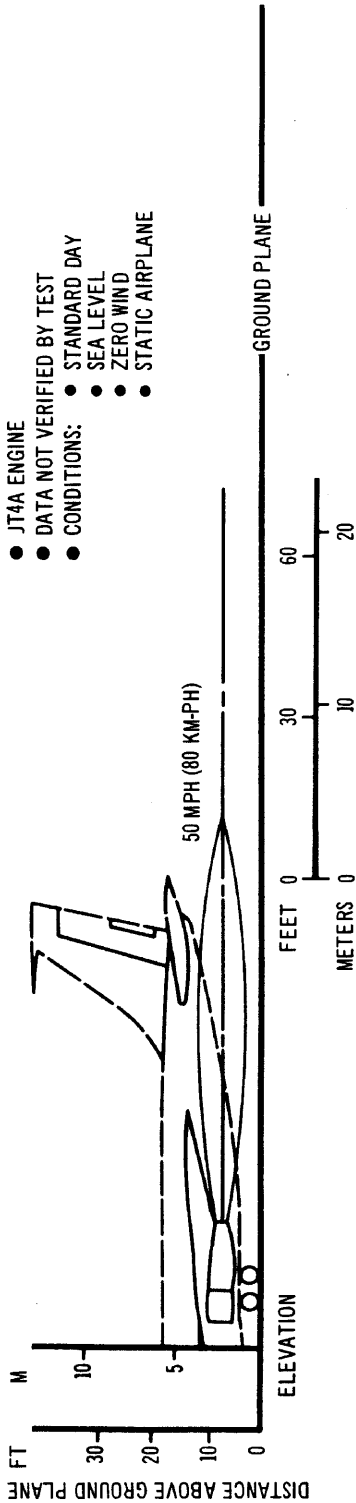

JET ENGINE EXHAUST - VELOCITY CONTOURS - IDLE POWER
 MODEL 707-320

**JET ENGINE EXHAUST - TEMPERATURE CONTOURS - IDLE POWER
MODEL 707-320**

- NOTES:**
- JT4A ENGINE
 - DATA NOT VERIFIED BY TEST
 - CONDITIONS:
 - STANDARD DAY
 - SEA LEVEL
 - ZERO WIND
 - STATIC AIRPLANE

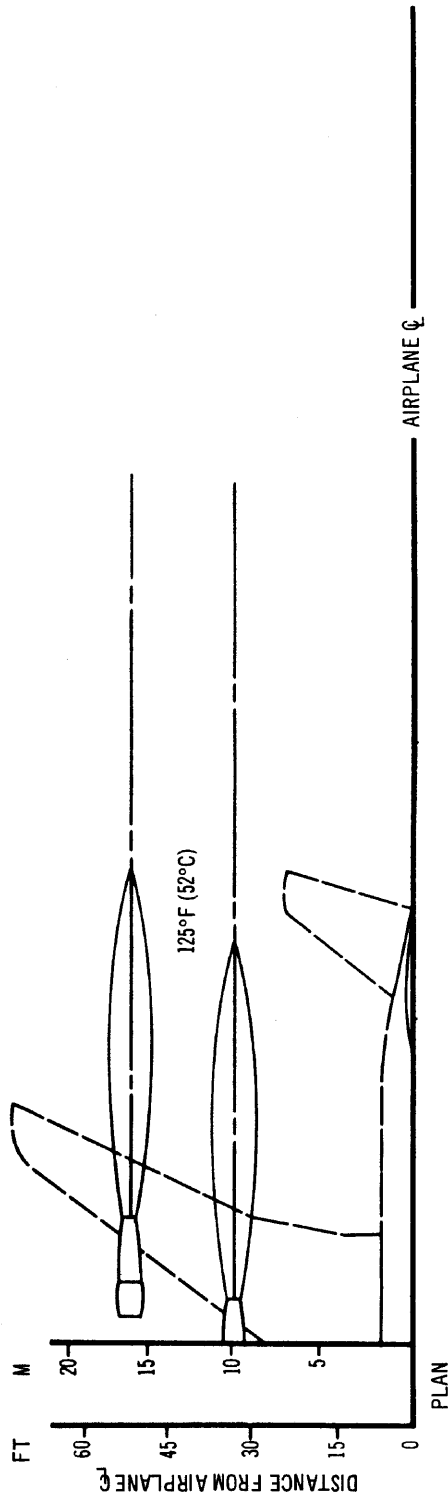
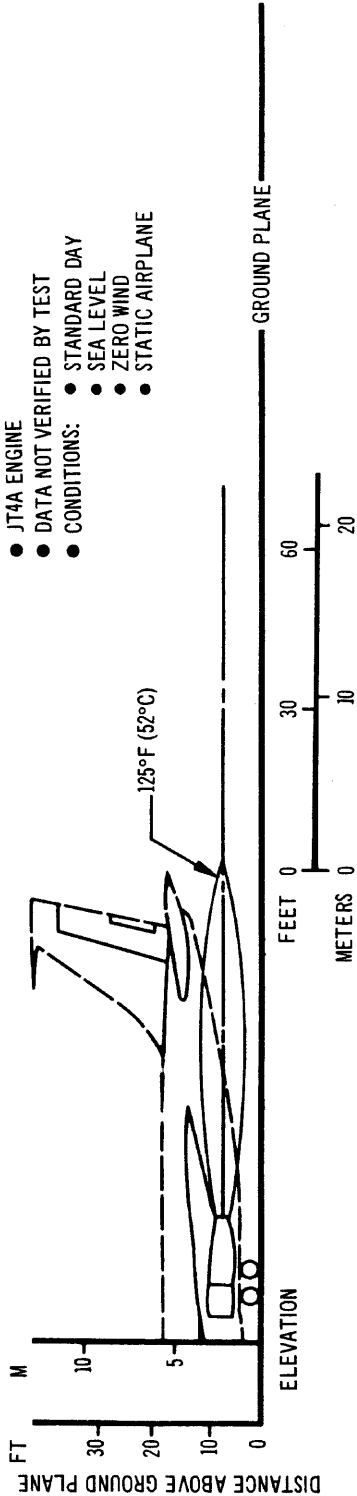

- NOTES:
- JT4A ENGINE
 - DATA NOT VERIFIED BY TEST
 - STANDARD DAY
 - SEA LEVEL
 - ZERO WIND
 - STATIC AIRPLANE TO LEVEL
 - STRAIGHT AHEAD MOVEMENT

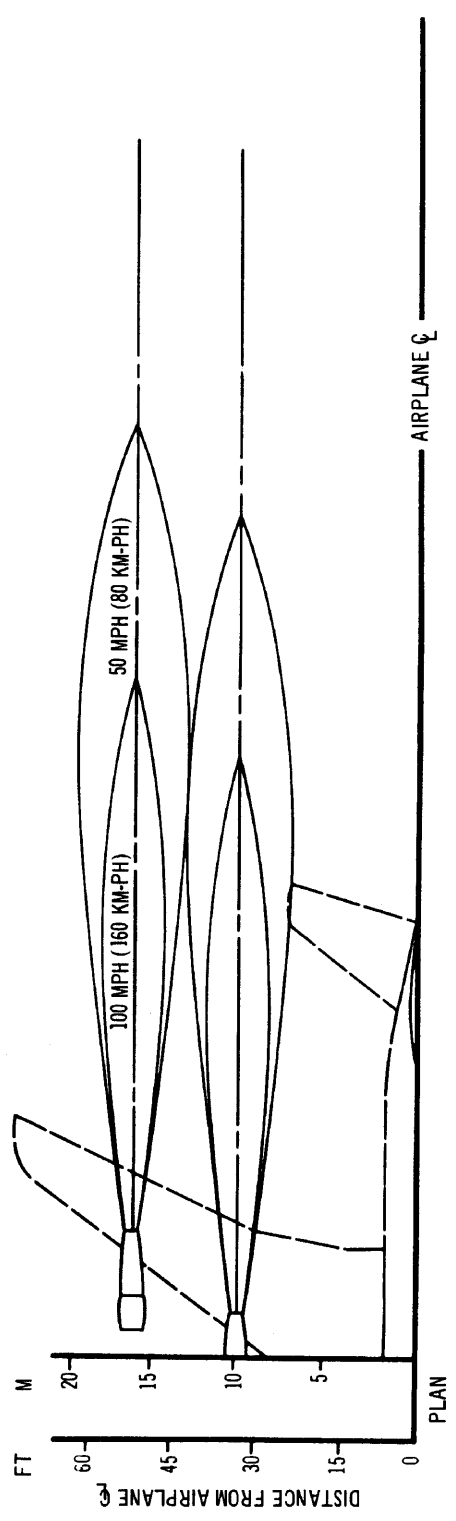
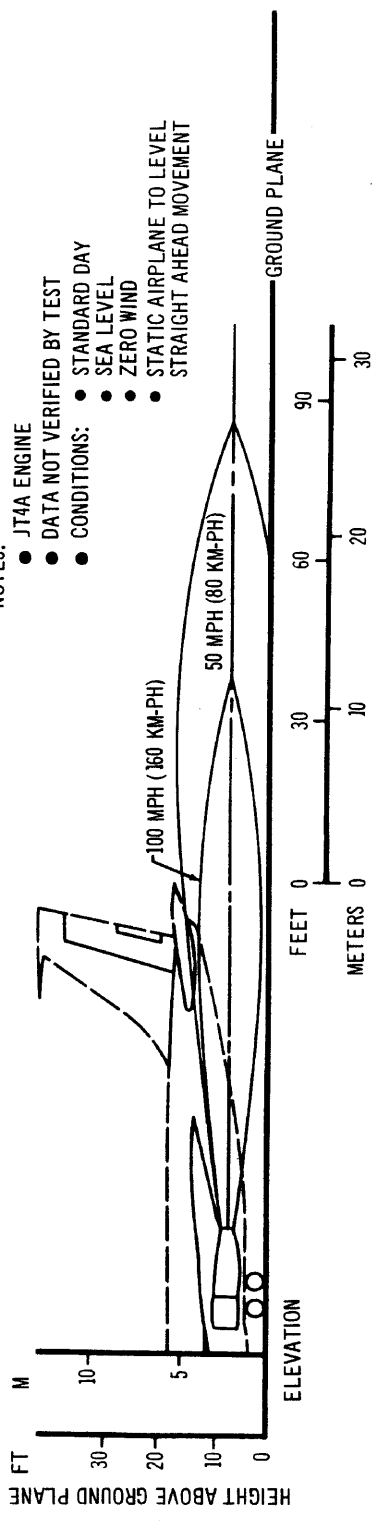

**JET ENGINE EXHAUST - VELOCITY CONTOURS - BREAKAWAY POWER
MODEL 707-320**

**JET ENGINE EXHAUST - TEMPERATURE CONTOURS - BREAKAWAY POWER
MODEL 707-320**

- NOTES:
- JT4A ENGINE
 - DATA NOT VERIFIED BY TEST
 - STANDARD DAY
 - SEA LEVEL
 - ZERO WIND
 - STATIC AIRPLANE TO LEVEL
 - STRAIGHT AHEAD MOVEMENT

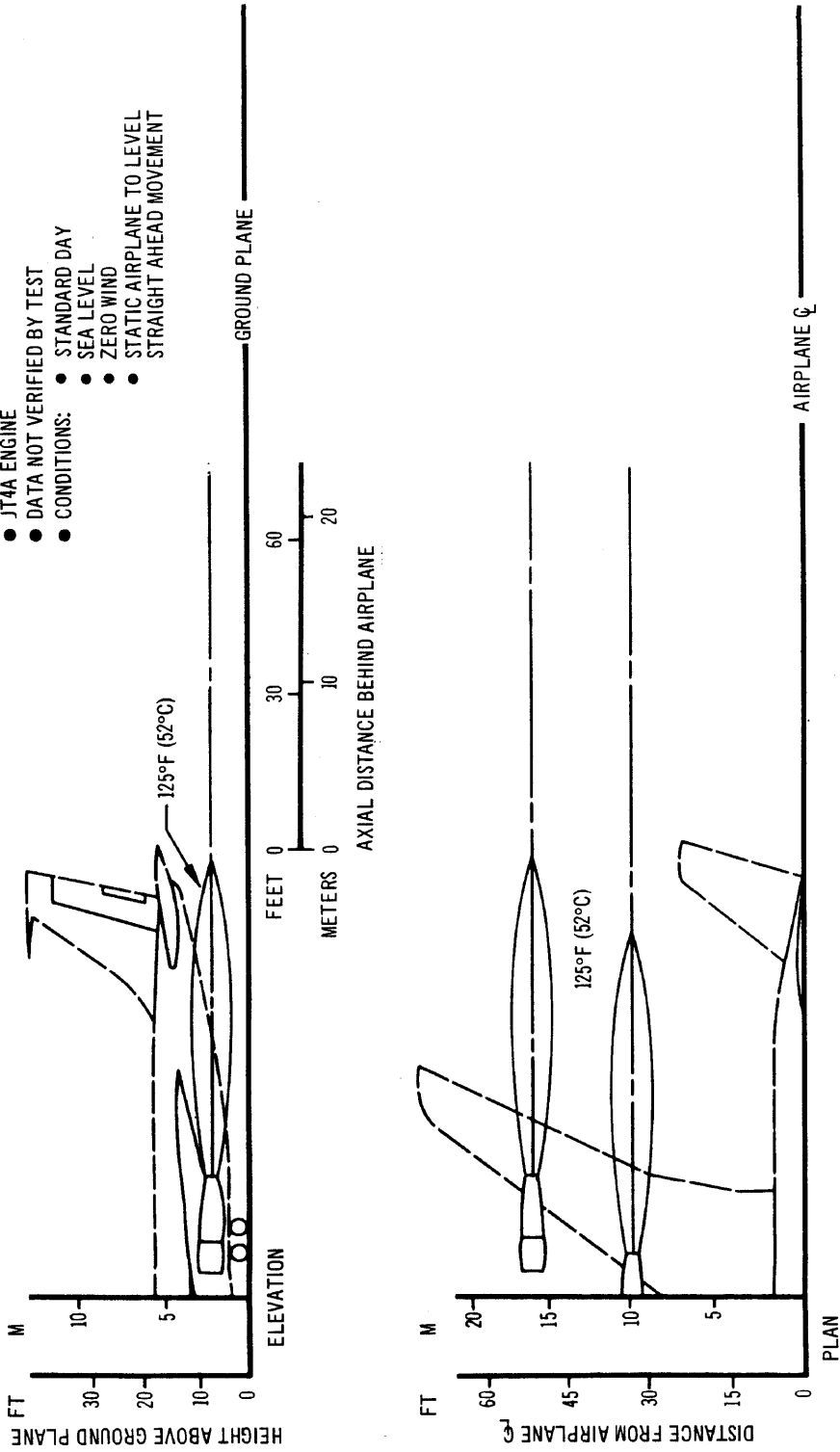

NOTES:

- JT4A ENGINE
- DATA NOT VERIFIED BY TEST
- CONDITIONS:
- STANDARD DAY
- SEA LEVEL
- ZERO WIND
- STATIC AIRPLANE

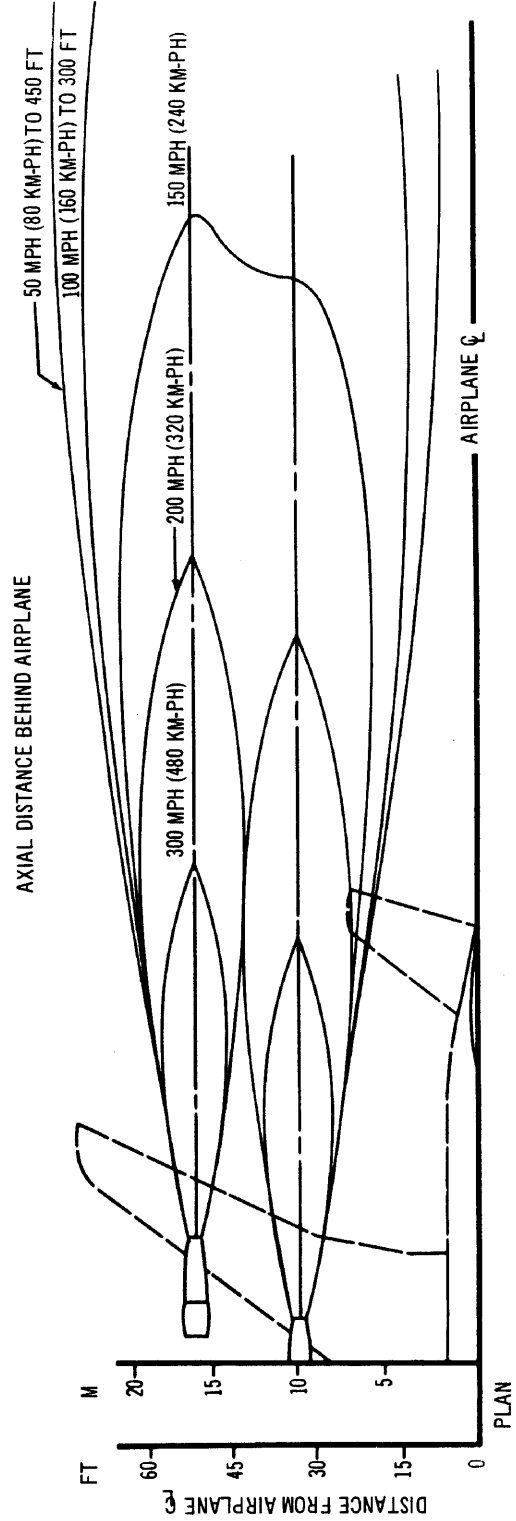
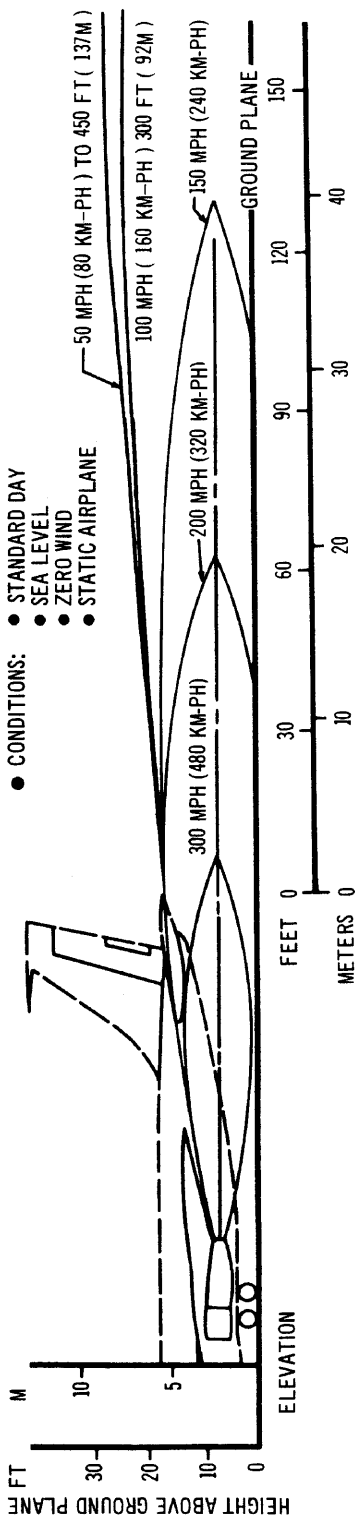

JET ENGINE EXHAUST - VELOCITY CONTOURS - MAXIMUM POWER
MODEL 707-320

- NOTES:
- JT4A ENGINE
 - DATA NOT VERIFIED BY TEST
 - CONDITIONS:
 - STANDARD DAY
 - SEA LEVEL
 - ZERO WIND
 - STATIC AIRPLANE

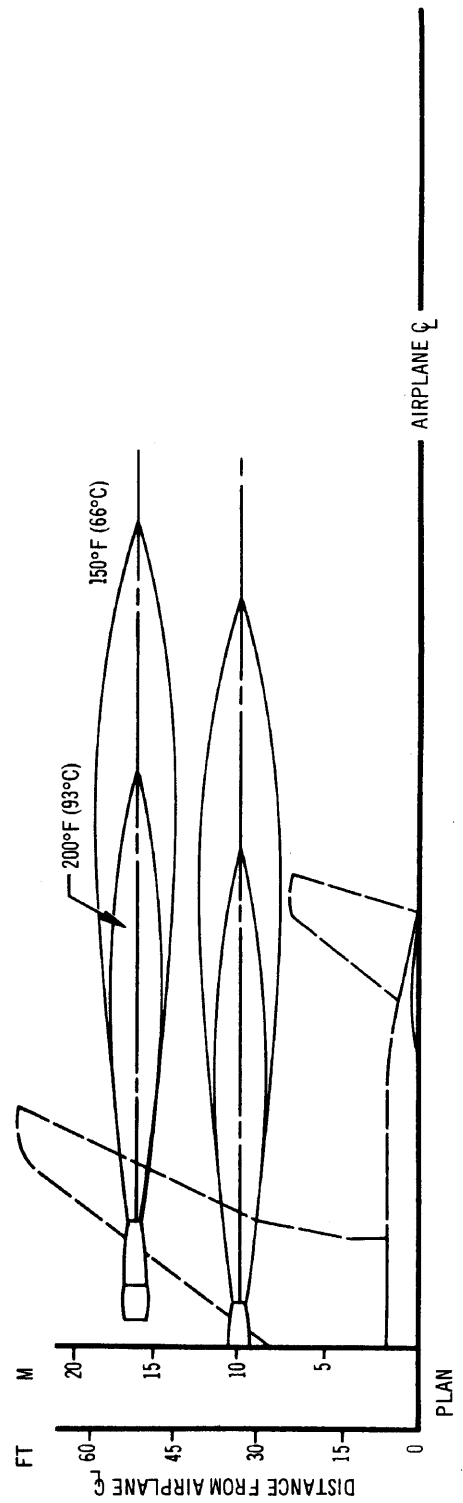
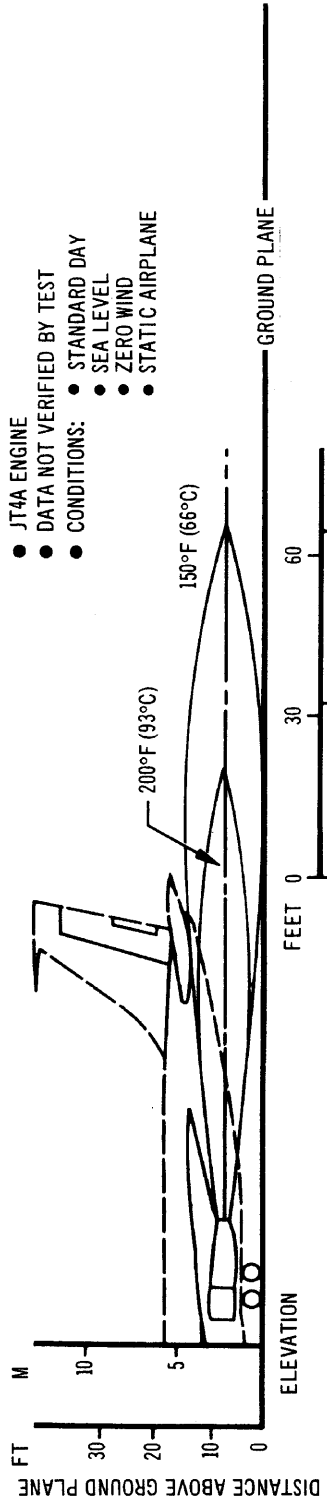

JET ENGINE EXHAUST - TEMPERATURE CONTOURS - MAXIMUM POWER
MODEL 707-320

- NOTES:
- R. Co. -12 ENGINE
 - DATA NOT VERIFIED BY TEST
 - CONDITIONS:
 - STANDARD DAY
 - SEA LEVEL
 - ZERO WIND
 - STATIC AIRPLANE

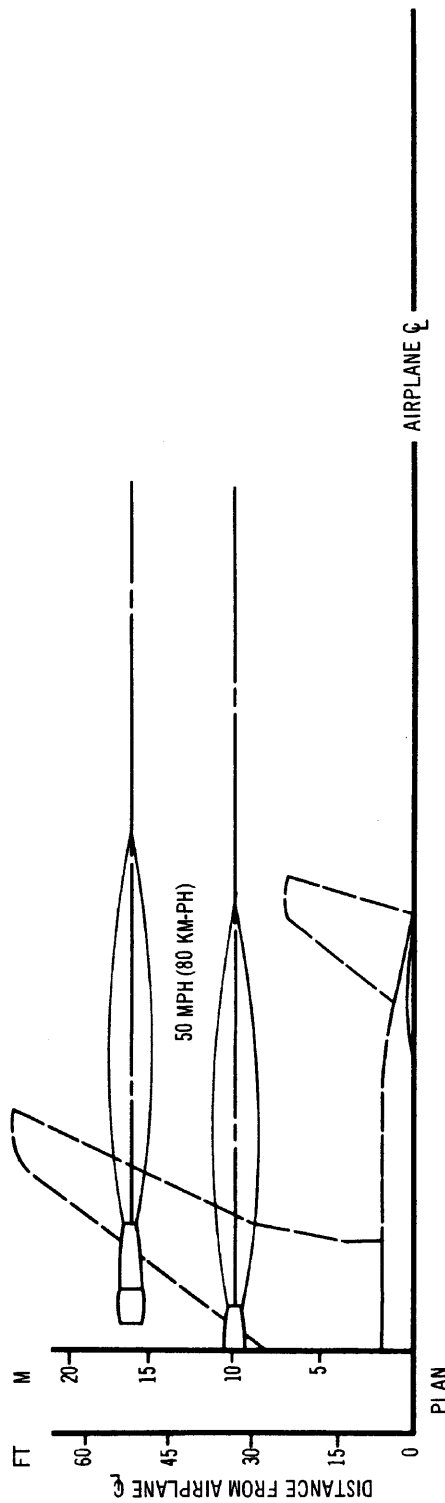
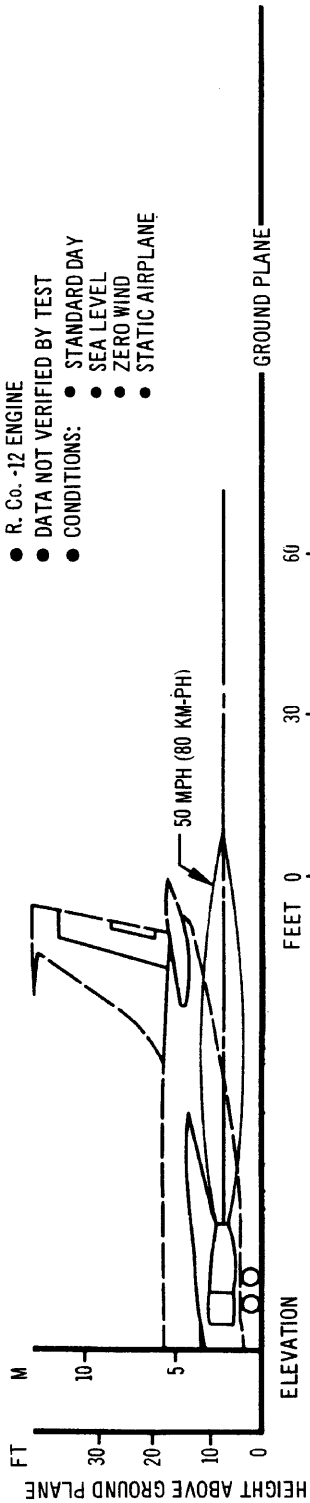

JET ENGINE EXHAUST - VELOCITY CONTOURS - IDLE POWER
MODEL 707-420

**JET ENGINE EXHAUST - TEMPERATURE CONTOURS - IDLE POWER
MODEL 707-420**

- NOTES:**
- R. Co. -12 ENGINE
 - DATA NOT VERIFIED BY TEST
 - CONDITIONS:
 - STANDARD DAY
 - SEA LEVEL
 - ZERO WIND
 - STATIC AIRPLANE

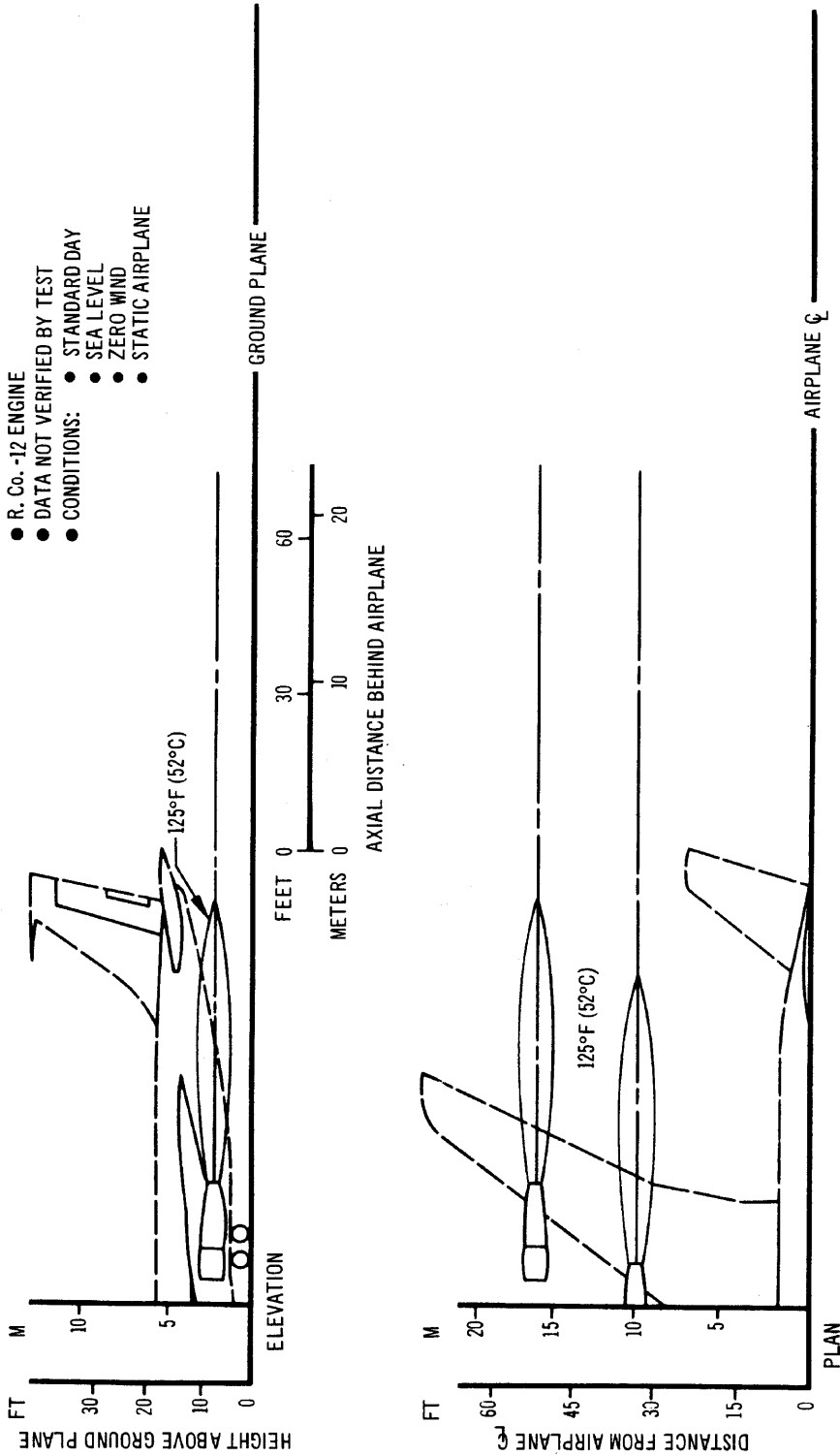

- NOTES:
- R. Co. -12 ENGINE
 - DATA NOT VERIFIED BY TEST
 - STANDARD DAY
 - CONDITIONS:
 - SEA LEVEL
 - ZERO WIND
 - STATIC AIRPLANE TO LEVEL
 - STRAIGHT AHEAD MOVEMENT

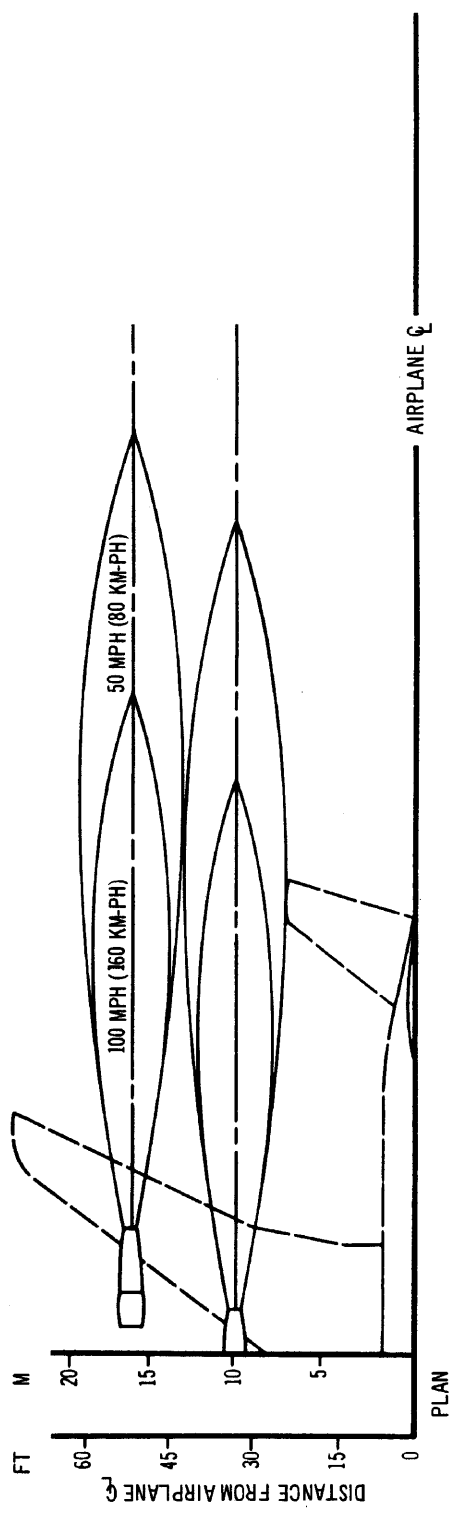
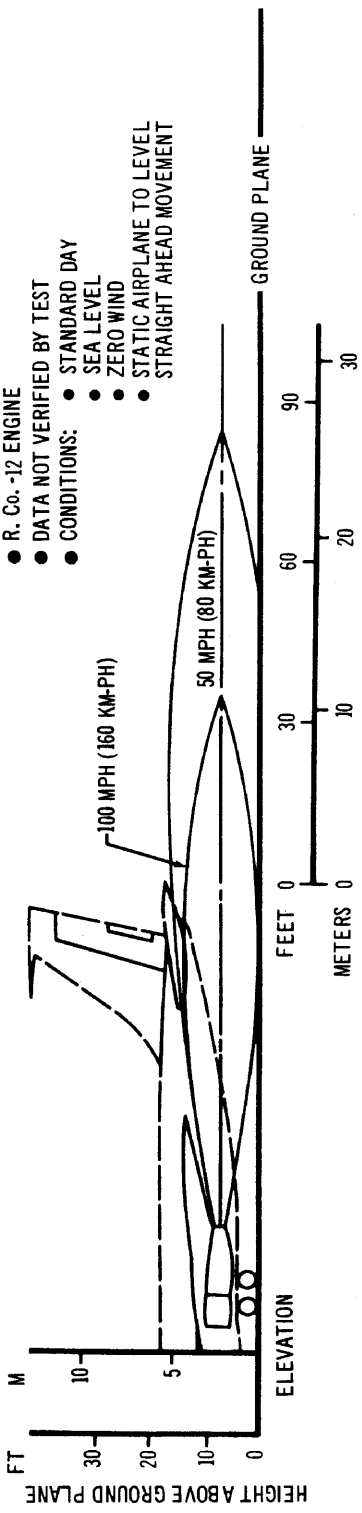

JET ENGINE EXHAUST - VELOCITY CONTOURS - BREAKAWAY POWER
MODEL 707-420

**JET ENGINE EXHAUST - TEMPERATURE CONTOURS - BREAKAWAY POWER
MODEL 707-420**

- NOTES:**
- R. Co. -12 ENGINE
 - DATA NOT VERIFIED BY TEST
 - CONDITIONS:
 - STANDARD DAY
 - SEA LEVEL
 - ZERO WIND
 - STATIC AIRPLANE TO LEVEL
 - STRAIGHT AHEAD MOVEMENT

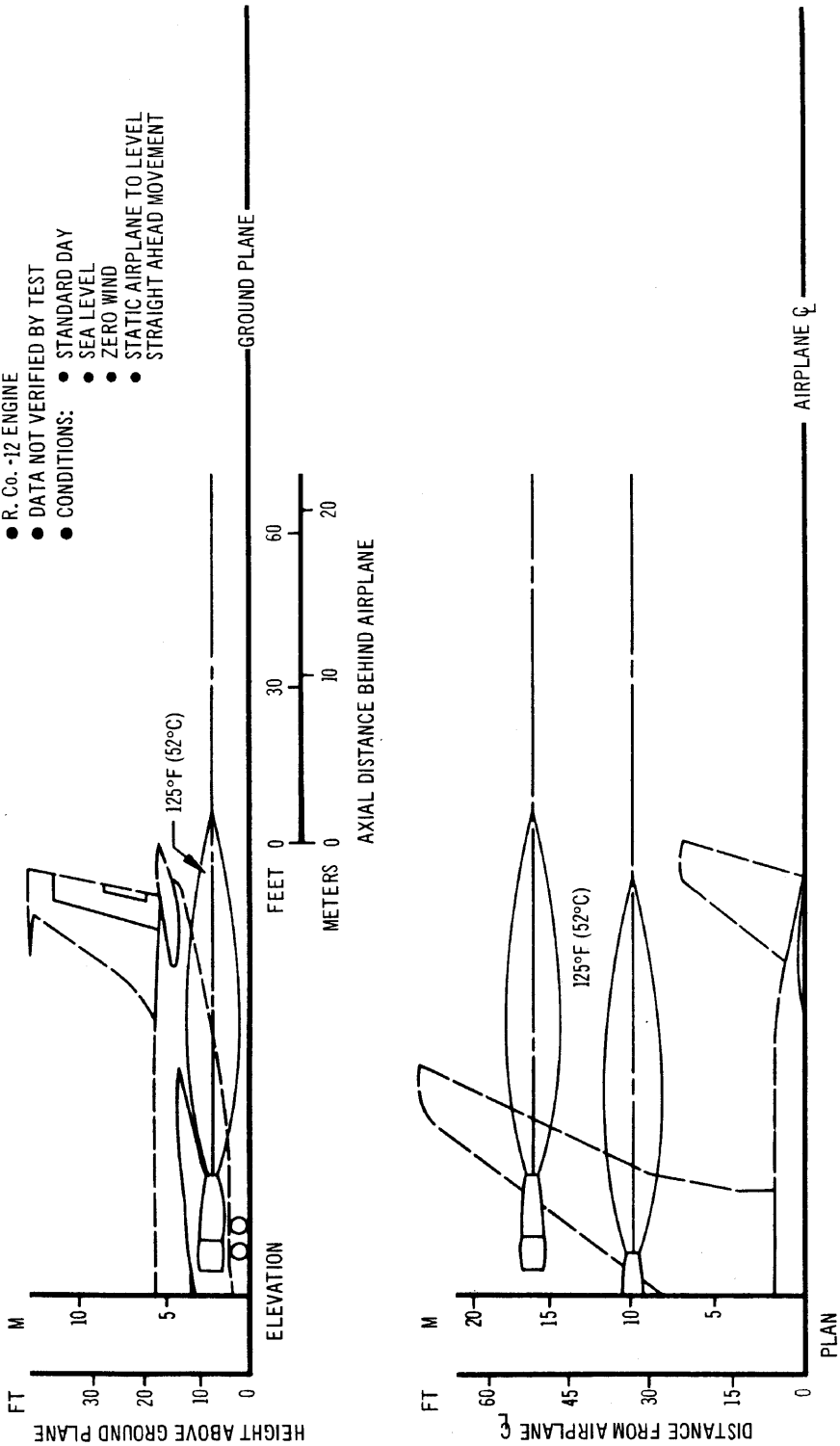

NOTES:

- R. Co. -12 ENGINE
- DATA NOT VERIFIED BY TEST
- CONDITIONS: ● STANDARD DAY
- SEA LEVEL
- ZERO WIND
- STATIC AIRPLANE

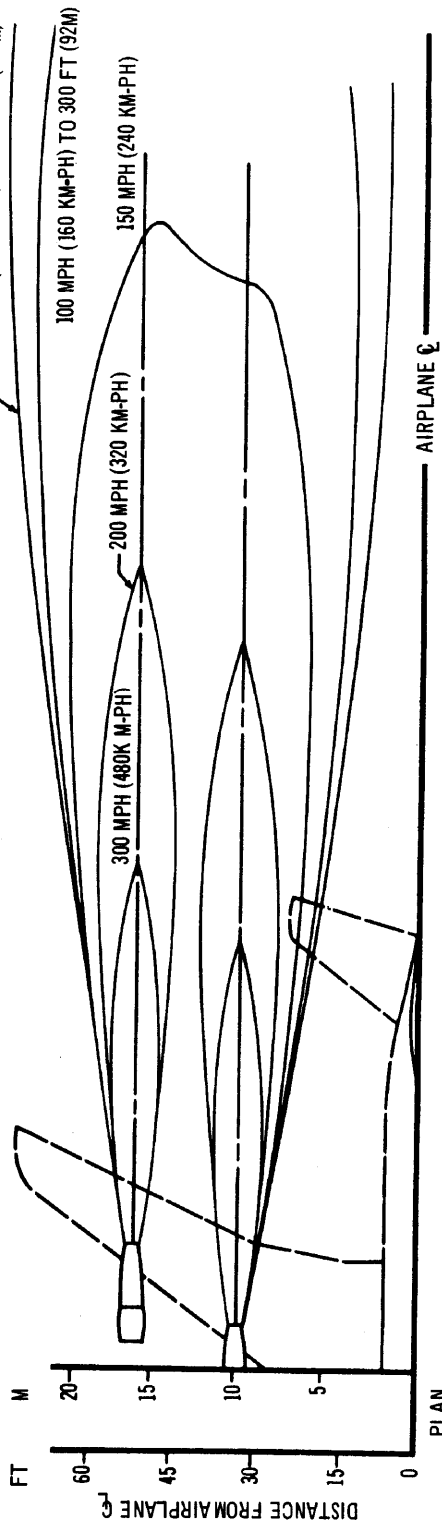
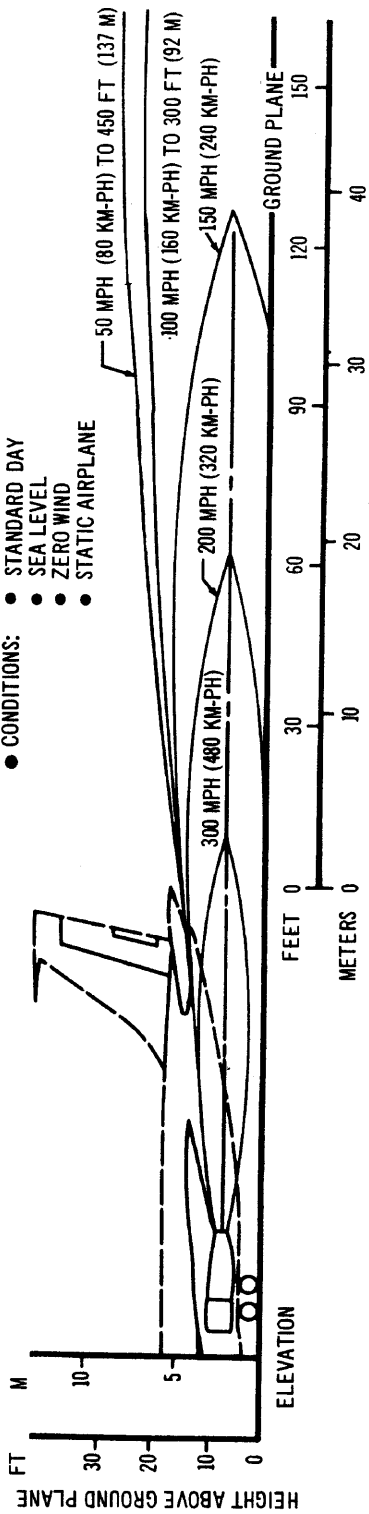

JET ENGINE EXHAUST - VELOCITY CONTOURS - MAXIMUM POWER
MODEL 707-420

**JET ENGINE EXHAUST - TEMPERATURE CONTOURS - MAXIMUM POWER
MODEL 707-420**

- NOTES:**
- R. Co. -12 ENGINE
 - DATA NOT VERIFIED BY TEST
 - CONDITIONS:
 - STANDARD DAY
 - SEA LEVEL
 - ZERO WIND
 - STATIC AIRPLANE

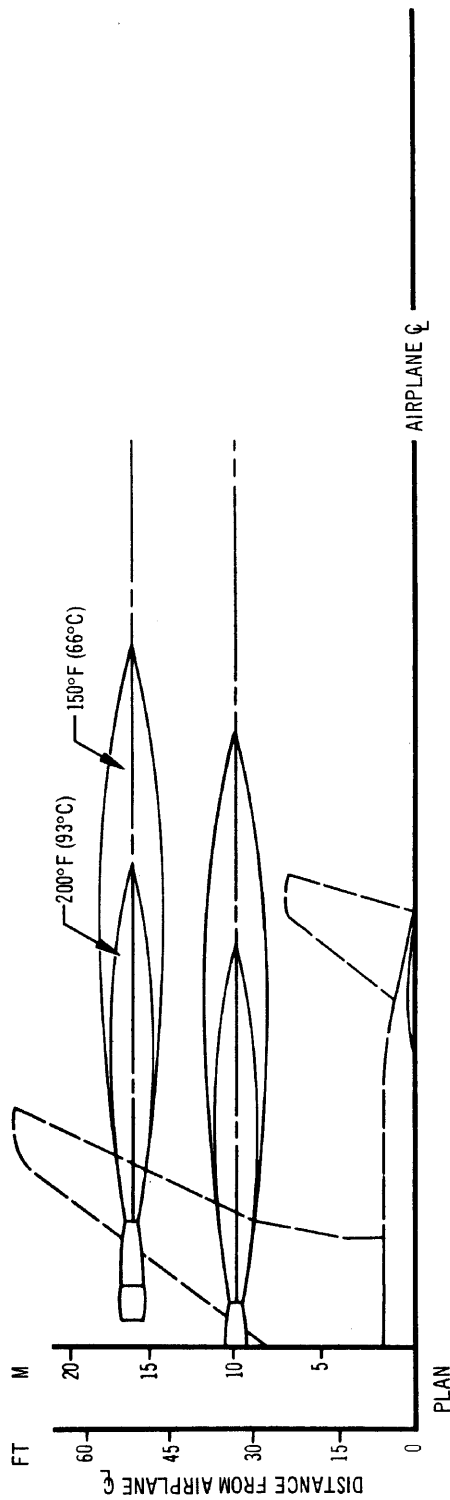
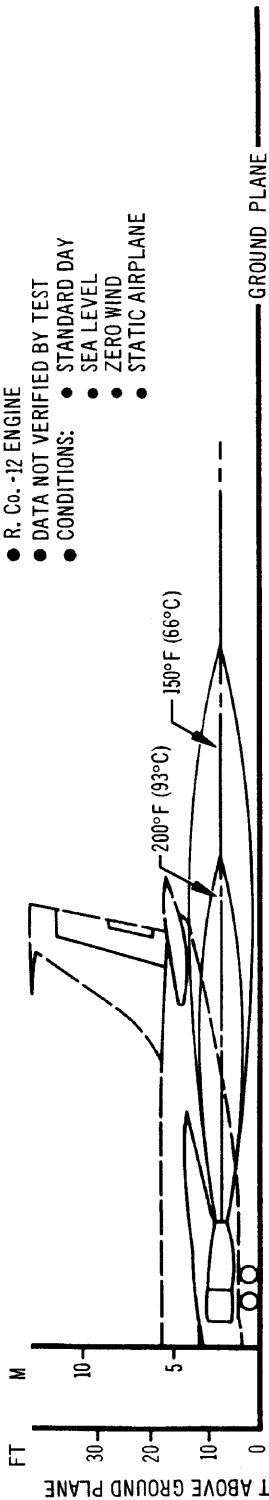

6.2 AIRPORT AND COMMUNITY NOISE

Noise level footprint contours will be developed and displayed in the document at some future date. These contours will reflect the noise level impingement upon a theoretical ground level plane at the same elevation as the runway. Contours will be provided for both takeoff and landing operations.

These footprint contours will permit investigations at individual airports of the noise associated with operation of the airplane as it relates to the airport proper and the adjoining community. This will assist in planning investigations related to clear zones, zoning for nonsensitive land utilization, or alternate compatible land development.

As an interim measure for airport planning it is recommended that FAA DS-67-14 "Techniques for Developing Noise Exposure Forecasts," with the exception of Section 4 "Land Use Planning," be used as representative of noise contours for 2, 3 and 4 engine airplanes. It must be kept in mind that the data presented is for effective perceived noise level in units of EPNdB, and as such must be considered to have a tolerance of ± 8 EPNdB.