

PRELIMINARY

4.0 GROUND MANEUVERING

4.1 General Information

4.2 Turning Radii

4.3 Clearance Radii

4.4 Visibility from Cockpit in Static Position

4.5 Runway and Taxiway Turn Paths

4.6 Runway Holding Bay

PRELIMINARY

4.0 GROUND MANEUVERING

4.1 General Information

The 747-8F main landing gear consists of four main struts, each strut with four wheels. This geometric arrangement of the four main gears results in somewhat different ground maneuvering characteristics from those experienced with typical landing gear aircraft.

Basic factors that influence the geometry of the turn include:

1. Nose wheel steering angle
2. Engine power settings
3. Center of gravity location
4. Airplane weight
5. Pavement surface conditions
6. Amount of differential braking
7. Ground speed
8. Main landing gear steering

The steering system of the 747-8 Freighter incorporates steering of the main body landing gear in addition to the nose gear steering. This body gear steering system is hydraulically actuated and is programmed electrically to provide steering ratios proportionate to the nose gear steering angles. During takeoff and landing, the body gear steering system is centered, mechanically locked, and depressurized.

Steering of the main body gear has the following advantages over ground maneuvering without this steering feature; overall improved maneuverability, including improved nose gear tracking; elimination of the need for differential braking during ground turns, with subsequent reduced brake wear; reduced thrust requirements; lower main gear stress levels; and reduced tire scrubbing. The turning radii shown in Section 4.2 are derived from a previous test involving a 747-200. The 747-8F is expected to follow the same maneuvering characteristics.

PRELIMINARY

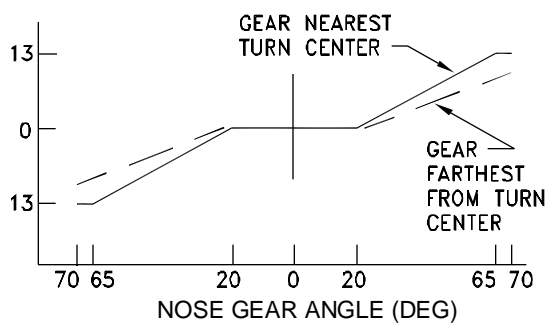
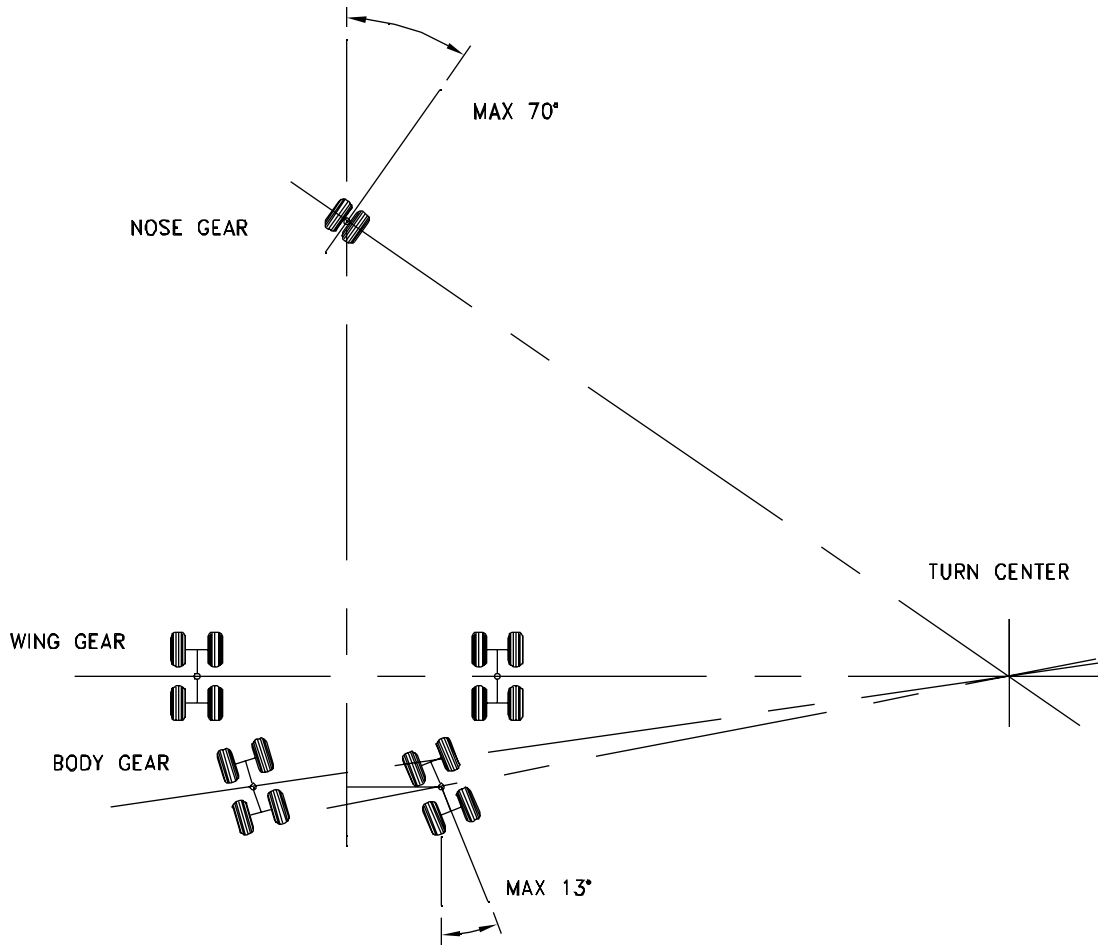

NOSE GEAR	BODY GEAR
0° TO 20°	0°
20° TO 70°	0° TO 13°

NOSE GEAR/BODY GEAR TURN RATIOS

4.1.1 GENERAL INFORMATION – BODY GEAR STEERING SYSTEM MODEL 747-8, 747-8F

PRELIMINARY

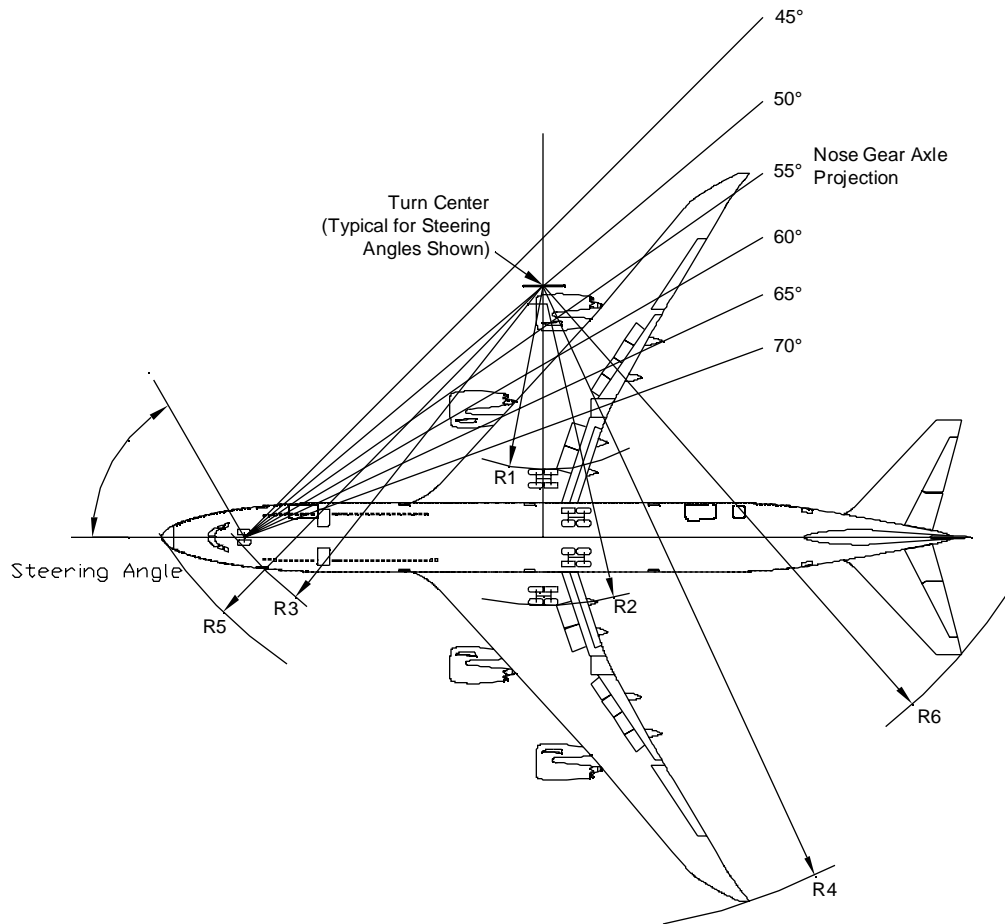

NOTES: DATA SHOWN FOR AIRPLANE WITH BODY GEAR STEERING
 ACTUAL OPERATING TURNING RADII MAY BE GREATER THAN SHOWN
 CONSULT WITH AIRLINE FOR SPECIFIC OPERATING PROCEDURE
 DIMENSIONS ROUNDED TO NEAREST FOOT AND 0.1 METER

STEERING ANGLE (DEG)	R1 INNER GEAR		R2 OUTER GEAR		R3 NOSE GEAR		R4 WING TIP		R5 NOSE		R6 TAIL	
	FT	M	FT	M	FT	M	FT	M	FT	M	FT	M
30	139	42.4	181	55.2	188	57.3	280	85.3	199	60.7	233	71.0
35	111	33.8	153	46.6	164	50.0	252	76.8	177	53.9	210	64.0
40	89	27.1	131	39.9	147	44.8	231	70.4	161	49.1	193	58.8
45	72	21.9	113	34.4	134	40.8	214	65.2	150	45.7	180	54.9
50	57	17.4	98	29.9	124	37.8	200	61.0	141	43.0	170	51.8
55	44	13.4	86	26.2	116	35.4	188	57.3	134	40.8	162	49.4
60	33	10.1	74	22.6	110	33.5	177	53.9	129	39.3	155	47.2
65	22	6.7	64	19.5	105	32.0	168	51.2	125	38.1	149	45.4
70 (MAX)	13	4.0	55	16.8	101	30.8	159	48.5	123	37.5	144	43.9

4.2.1 TURNING RADII – NO SLIP ANGLE – WITH BODY GEAR STEERING MODEL 747-8F

PRELIMINARY

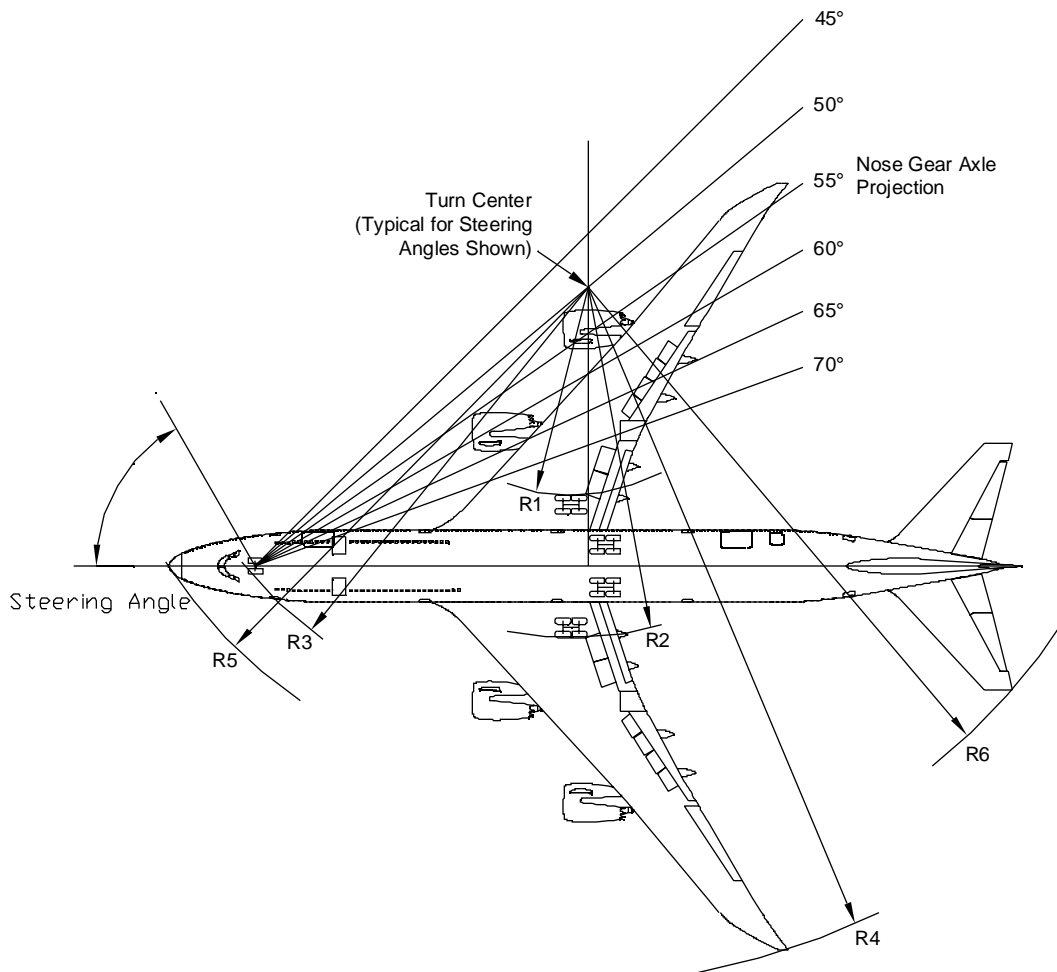

NOTES: DATA SHOWN FOR AIRPLANE WITH BODY GEAR STEERING INOPERATIVE
 ACTUAL OPERATING TURNING RADII MAY BE GREATER THAN SHOWN
 CONSULT WITH AIRLINE FOR SPECIFIC OPERATING PROCEDURE
 DIMENSIONS ROUNDED TO NEAREST FOOT AND 0.1 METER

STEERING ANGLE (DEG)	R1 INNER GEAR		R2 OUTER GEAR		R3 NOSE GEAR		R4 WING TIP		R5 NOSE		R6 TAIL	
	FT	M	FT	M	FT	M	FT	M	FT	M	FT	M
30	148	45.1	190	57.9	198	60.4	287	87.5	209	63.7	240	73.2
35	118	36.0	160	48.8	173	52.7	258	78.6	186	56.7	215	65.5
40	95	29.0	137	41.8	155	47.2	236	71.9	169	51.5	196	59.7
45	77	23.5	118	36.0	141	43.0	218	66.4	157	47.9	182	55.5
50	61	18.6	103	31.4	130	39.6	203	61.9	148	45.1	171	52.1
55	47	14.3	89	27.1	122	37.2	190	57.9	141	43.0	162	49.4
60	36	11.0	77	23.5	116	35.4	178	54.3	135	41.1	155	47.2
65	25	7.6	66	20.1	111	33.8	168	51.2	131	39.9	149	45.4
70 (MAX)	15	4.6	57	17.4	107	32.6	159	48.5	128	39.0	143	43.6

4.2.2 TURNING RADII – NO SLIP ANGLE –BODY GEAR STEERING INOPERATIVE MODEL 747-8F

PRELIMINARY

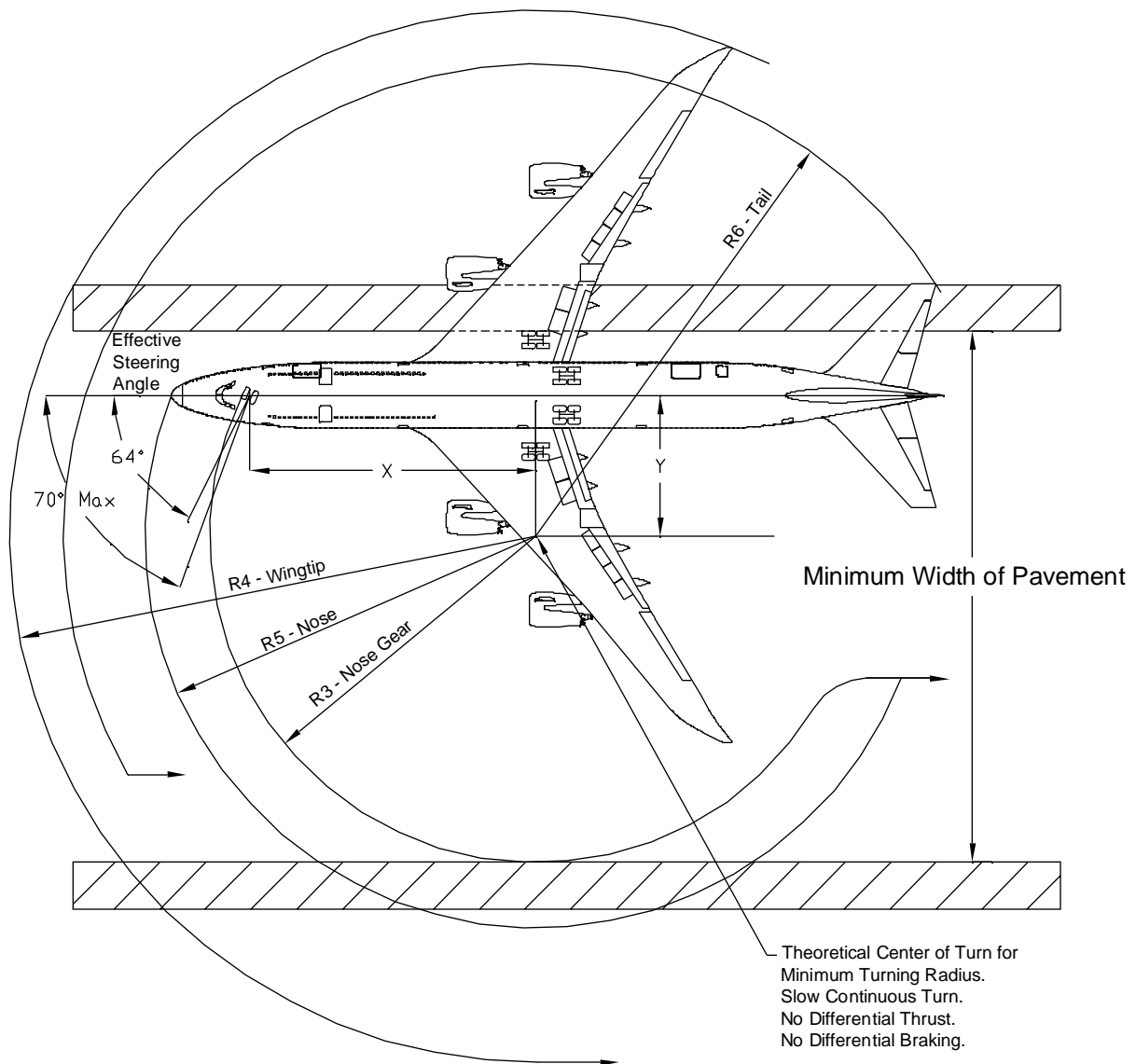

Notes:

- 6° Tire Slip Angle – Approximate Only For 70° Maximum Turn Angle
- Consult Airline For Actual Operating Data.

AIRPLANE MODEL	EFFECTIVE TURNING ANGLE (DEG)	X		Y		A		R3		R4		R5		R6	
		FT	M	FT	M	FT	M	FT	M	FT	M	FT	M	FT	M
747-8F	64	92	28.0	45	13.7	172	52.4	106	32.3	170	51.8	126	38.4	150	45.7

NOTE: DIMENSIONS ARE ROUNDED TO THE NEAREST FOOT AND 0.1 METER.

4.3.1 CLEARANCE RADII – WITH BODY GEAR STEERING
MODEL 747-8F

D6-58326-3

PRELIMINARY

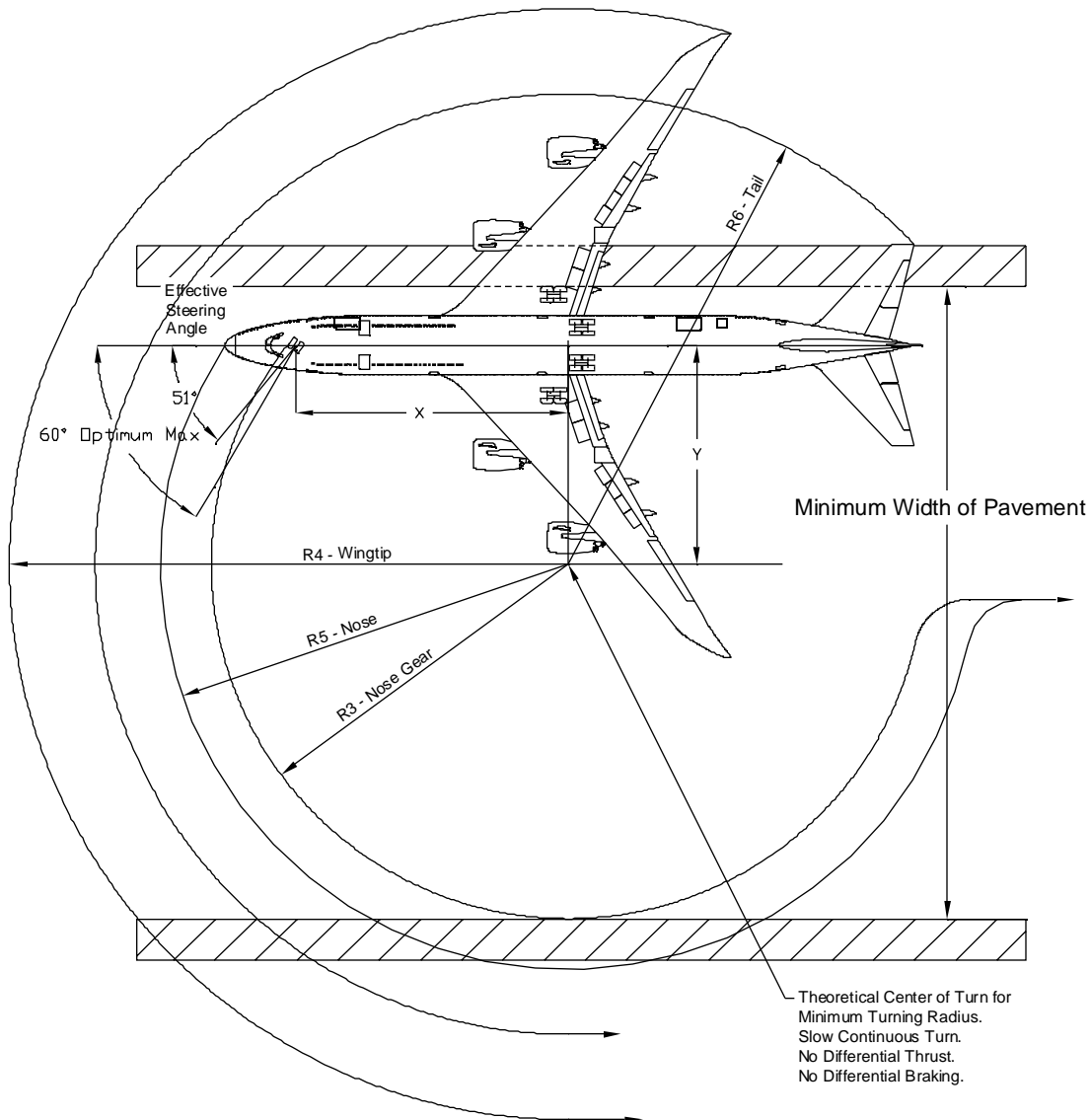

Notes:

- **Body Gear Steering Inoperative Rarely Occurs. Data Provided As Reference Only**
- **9° Tire Slip Angle – Approximate Only For 60° Turn Angle (Optimum Max Steering Angle)**
- **Consult Airline For Actual Operating Data.**

AIRPLANE MODEL	EFFECTIVE TURNING ANGLE (DEG)	X		Y		A		R3		R4		R5		R6	
		FT	M	FT	M	FT	M	FT	M	FT	M	FT	M	FT	M
747-8F	51	98	29.9	79	24.1	228	69.5	129	39.3	200	61.0	146	44.5	169	51.5

NOTE: DIMENSIONS ARE ROUNDED TO THE NEAREST FOOT AND 0.1 METER.

4.3.2 CLEARANCE RADII –BODY GEAR STEERING INOPERATIVE
MODEL 747-8F

PRELIMINARY

NOT TO BE USED FOR
LANDING APPROACH
VISIBILITY

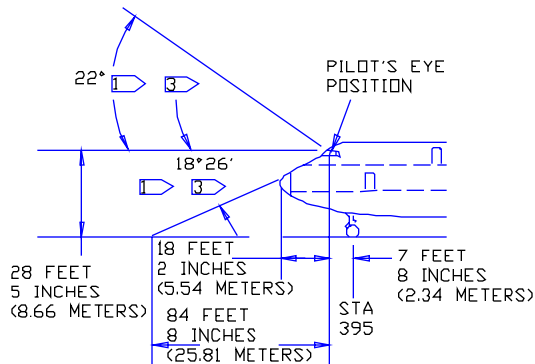

VISUAL ANGLES IN VERTICAL PLANE THROUGH PILOT'S EYE POSITION

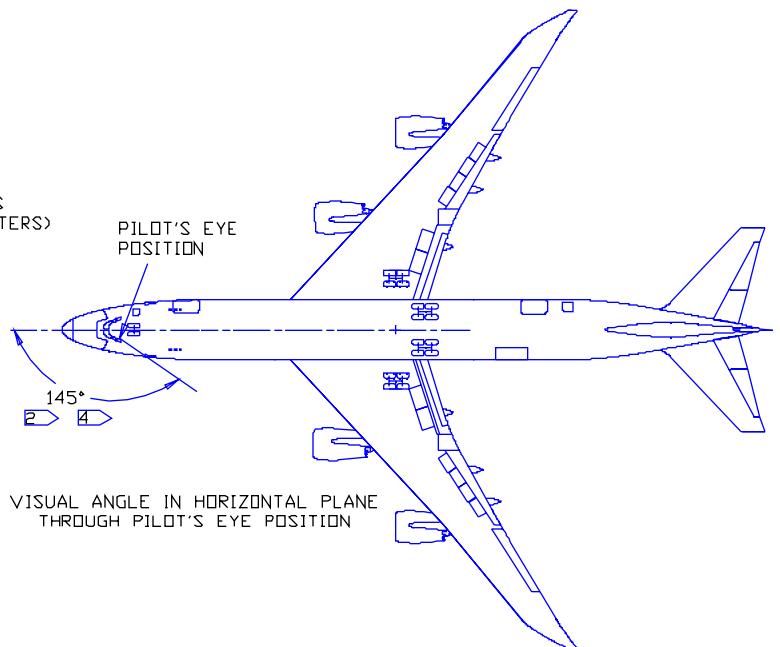

VISUAL ANGLE IN HORIZONTAL PLANE THROUGH PILOT'S EYE POSITION

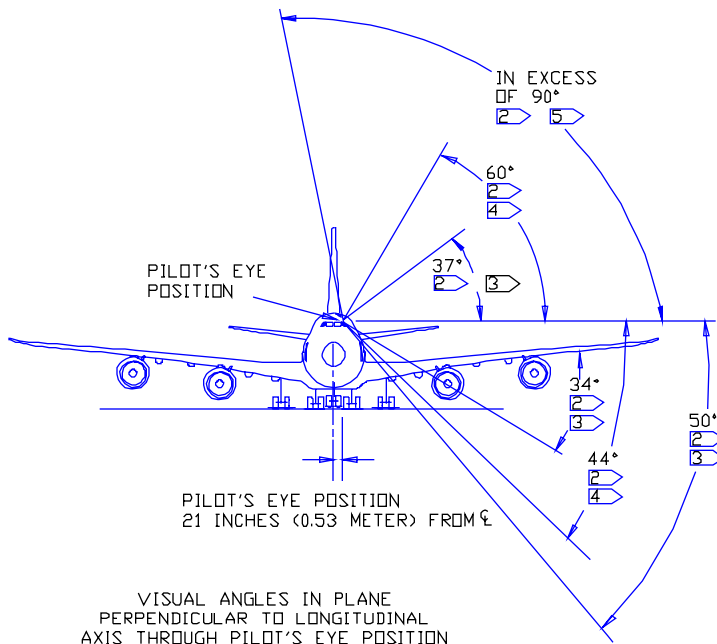

VISUAL ANGLES IN PLANE PERPENDICULAR TO LONGITUDINAL AXIS THROUGH PILOT'S EYE POSITION

NOTES:

- 1 VISUAL ANGLES THROUGH WINDSHIELD
- 2 VISUAL ANGLES THROUGH SIDE WINDOW
- 3 VISUAL ANGLES FROM NORMAL POSITION
- 4 VISUAL ANGLES FROM ALERT POSITION. HEAD MOVED OUTBOARD 5 INCHES (0.13 METERS)
- 5 VISUAL ANGLES WITH HEAD MOVED OUTBOARD 7 INCHES (0.18 METERS)

* HEAD IS ROTATED ABOUT A POINT 3 IN (0.08 METER) AFT OF PILOT'S EYE POSITION

4.4 VISIBILITY FROM COCKPIT IN STATIC POSITION MODEL 747-8F

PRELIMINARY

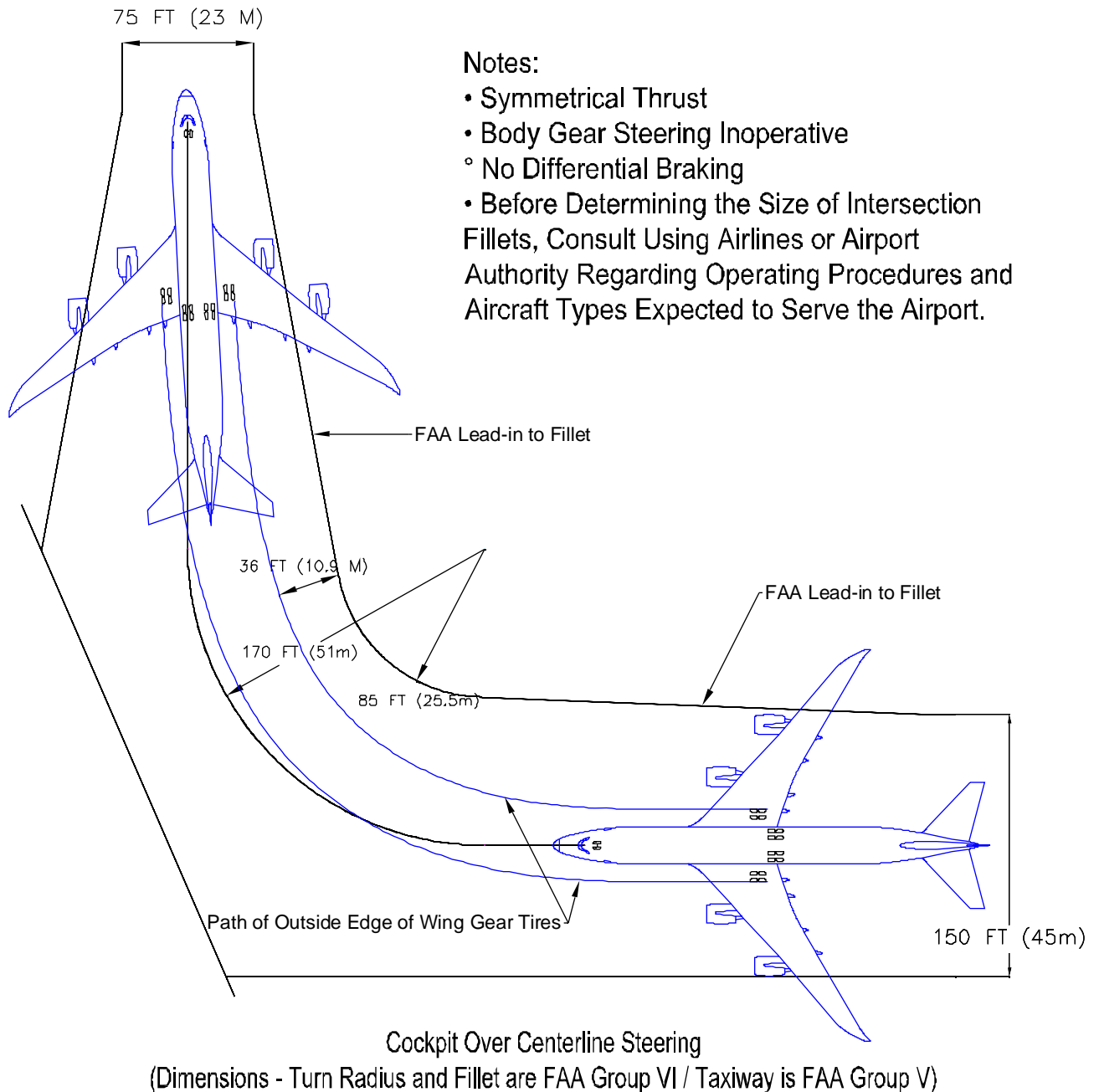

4.5.1 RUNWAY AND TAXIWAY TURNPATHS - RUNWAY-TO-TAXIWAY, 90 DEGREES, COCKPIT OVER CENTERLINE (FAA GROUP VI RADIUS/FILLET TO GROUP V TAXIWAY) MODEL 747-8F

PRELIMINARY

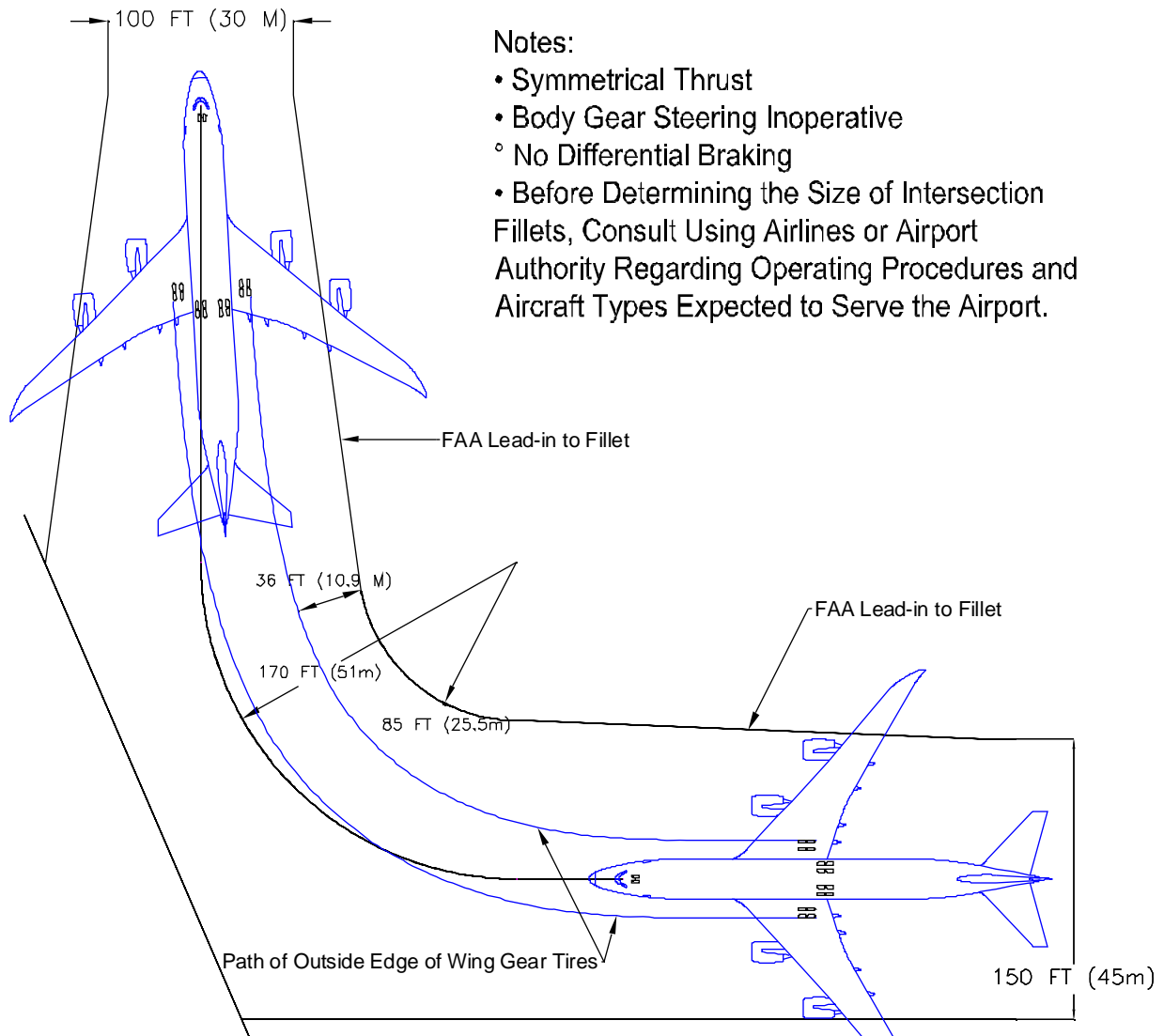

Notes:

- Symmetrical Thrust
- Body Gear Steering Inoperative
- ° No Differential Braking
- Before Determining the Size of Intersection Fillets, Consult Using Airlines or Airport Authority Regarding Operating Procedures and Aircraft Types Expected to Serve the Airport.

Cockpit Over Centerline Steering
(Dimensions - Turn Radius and Fillet are FAA Group VI / Taxiway is FAA Group VI)

4.5.2 RUNWAY AND TAXIWAY TURNPATHS - RUNWAY-TO-TAXIWAY, 90 DEGREES, COCKPIT OVER CENTERLINE (FAA GROUP VI RADIUS/FILLET TO GROUP VI TAXIWAY) MODEL 747-8F

PRELIMINARY

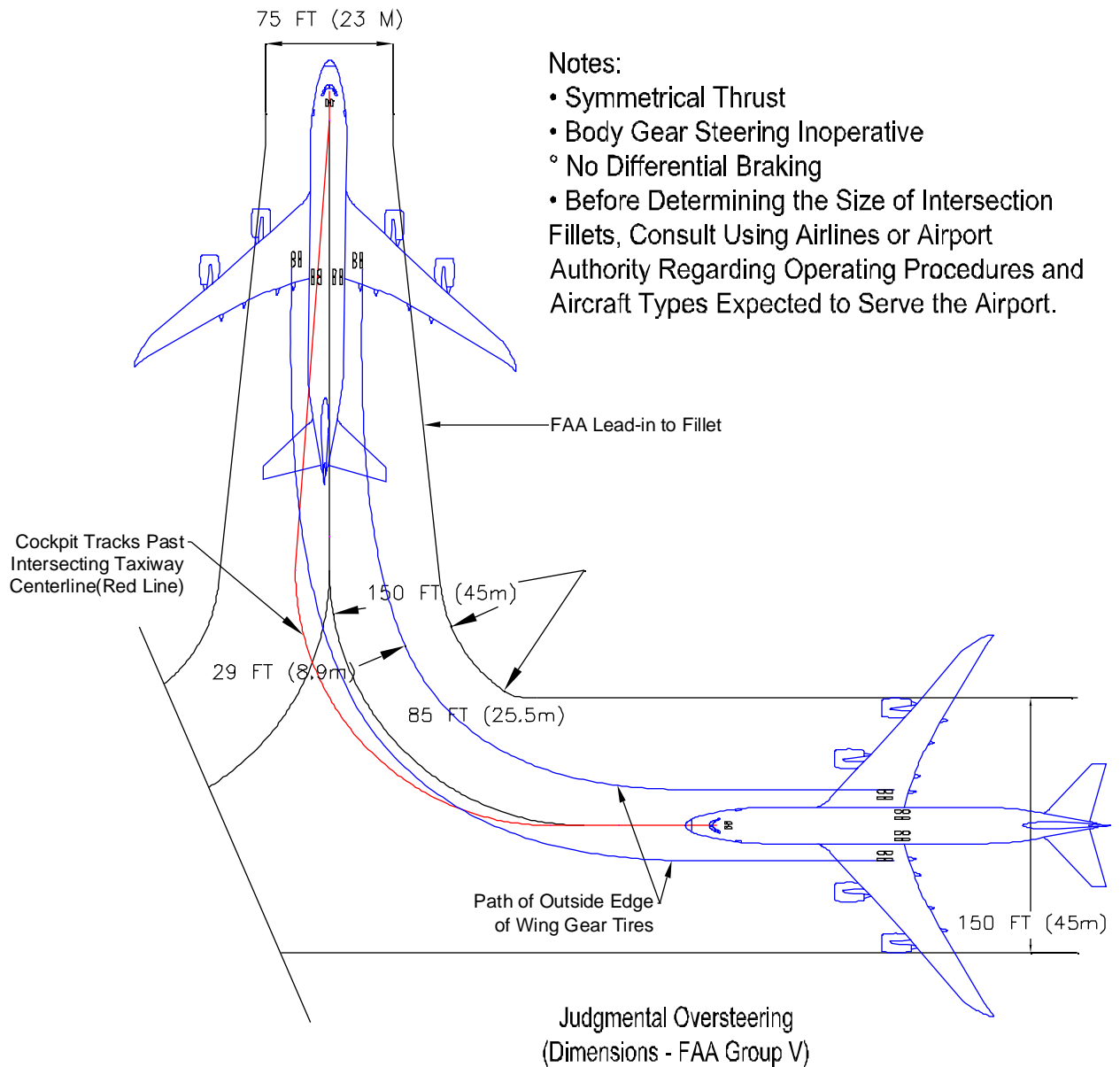

4.5.3 RUNWAY AND TAXIWAY TURNPATHS - RUNWAY-TO-TAXIWAY, 90 DEGREES, JUDGMENTAL OVERSTEER (FAA GROUP V RADIUS/FILLET TO GROUP V TAXIWAY) MODEL 747-8F

PRELIMINARY

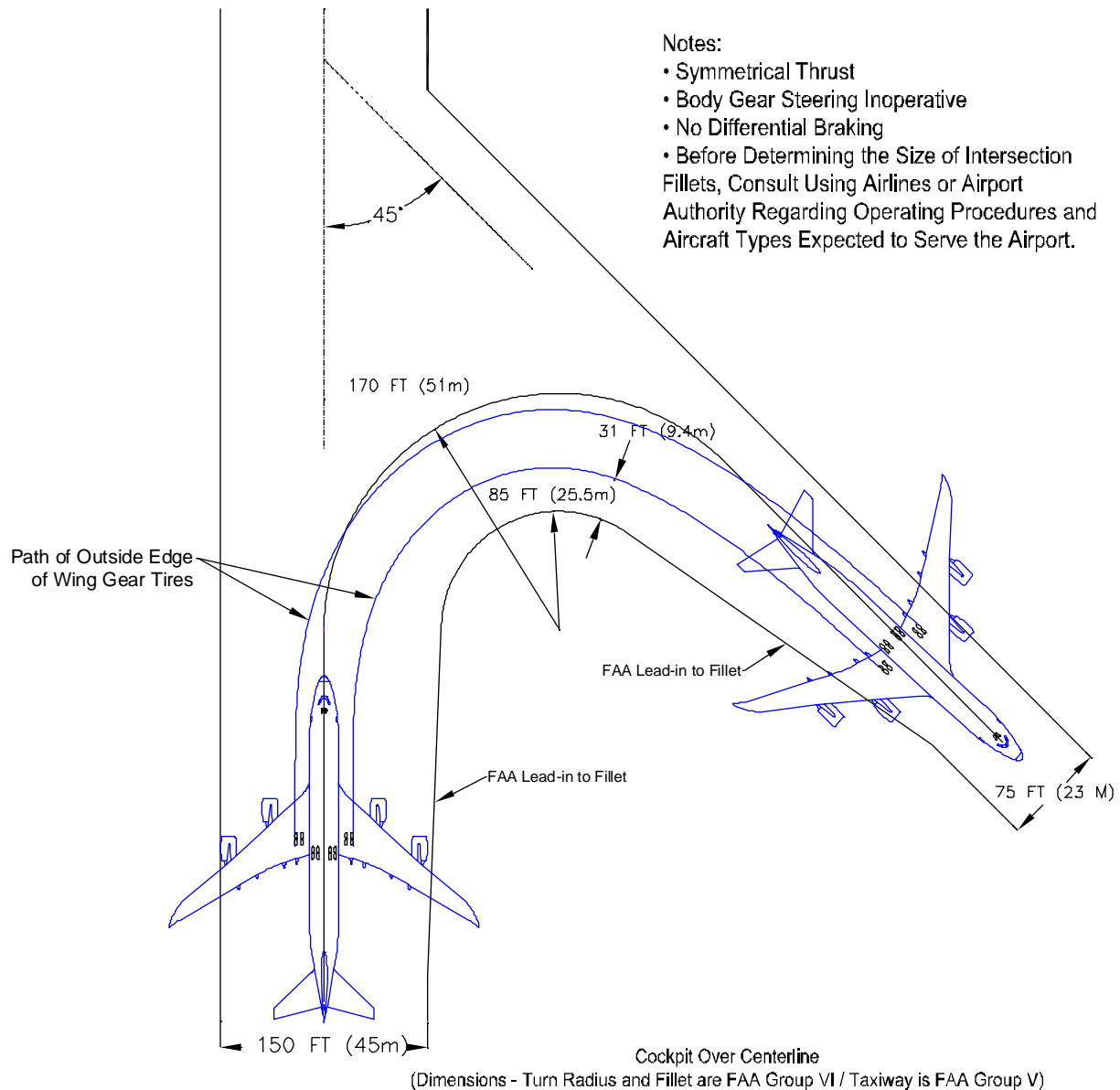

4.5.4 RUNWAY AND TAXIWAY TURNPATHS - RUNWAY-TO-TAXIWAY, MORE THAN 90 DEGREES, COCKPIT OVER CENTERLINE (FAA GROUP VI RADIUS TO GROUP V TAXIWAY)

MODEL 747-8F

PRELIMINARY

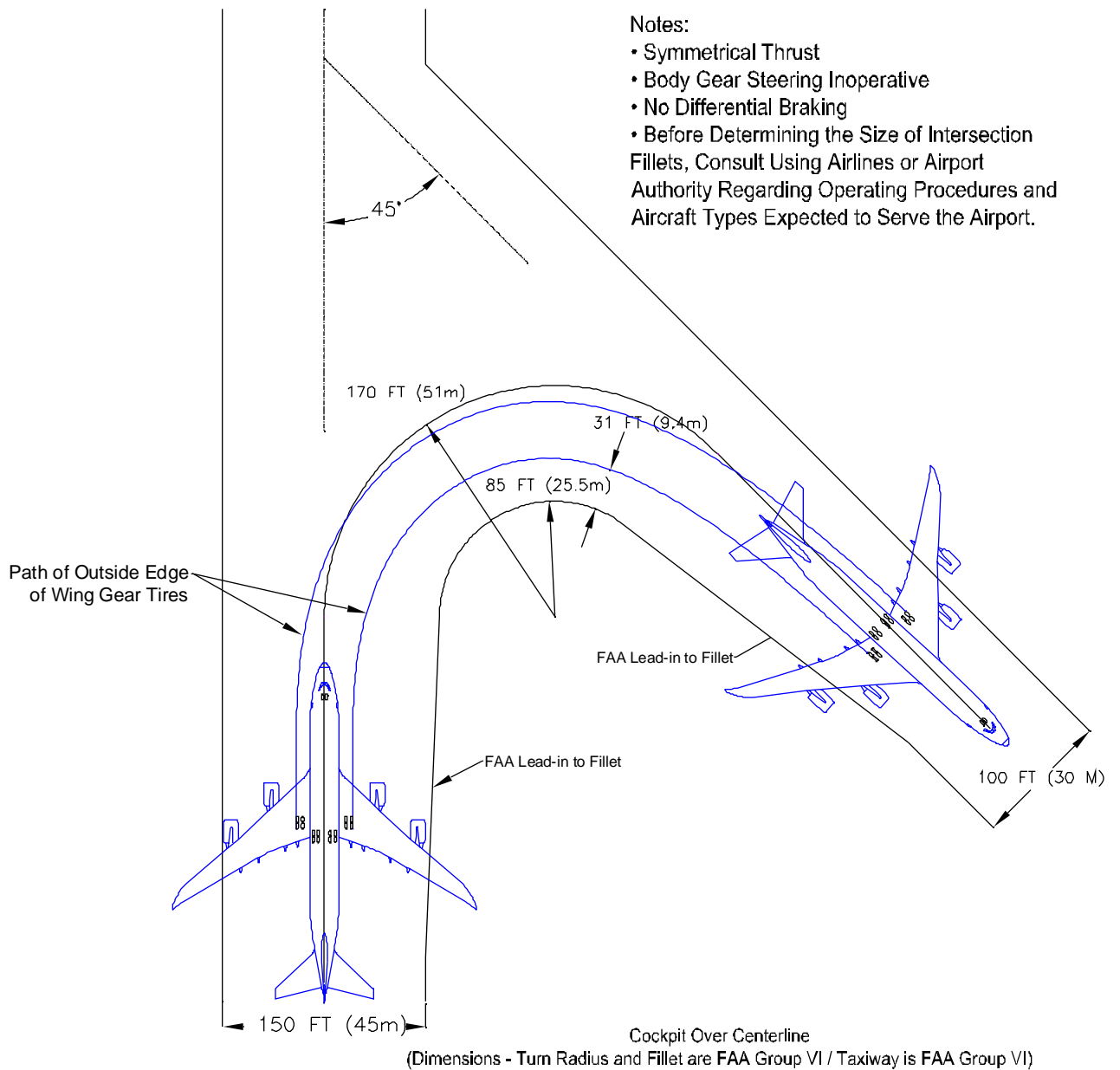

4.5.5 RUNWAY AND TAXIWAY TURNPATHS - RUNWAY-TO-TAXIWAY, MORE THAN 90 DEGREES, COCKPIT OVER CENTERLINE (FAA GROUP VI RADIUS TO GROUP VI TAXIWAY)

MODEL 747-8F

PRELIMINARY

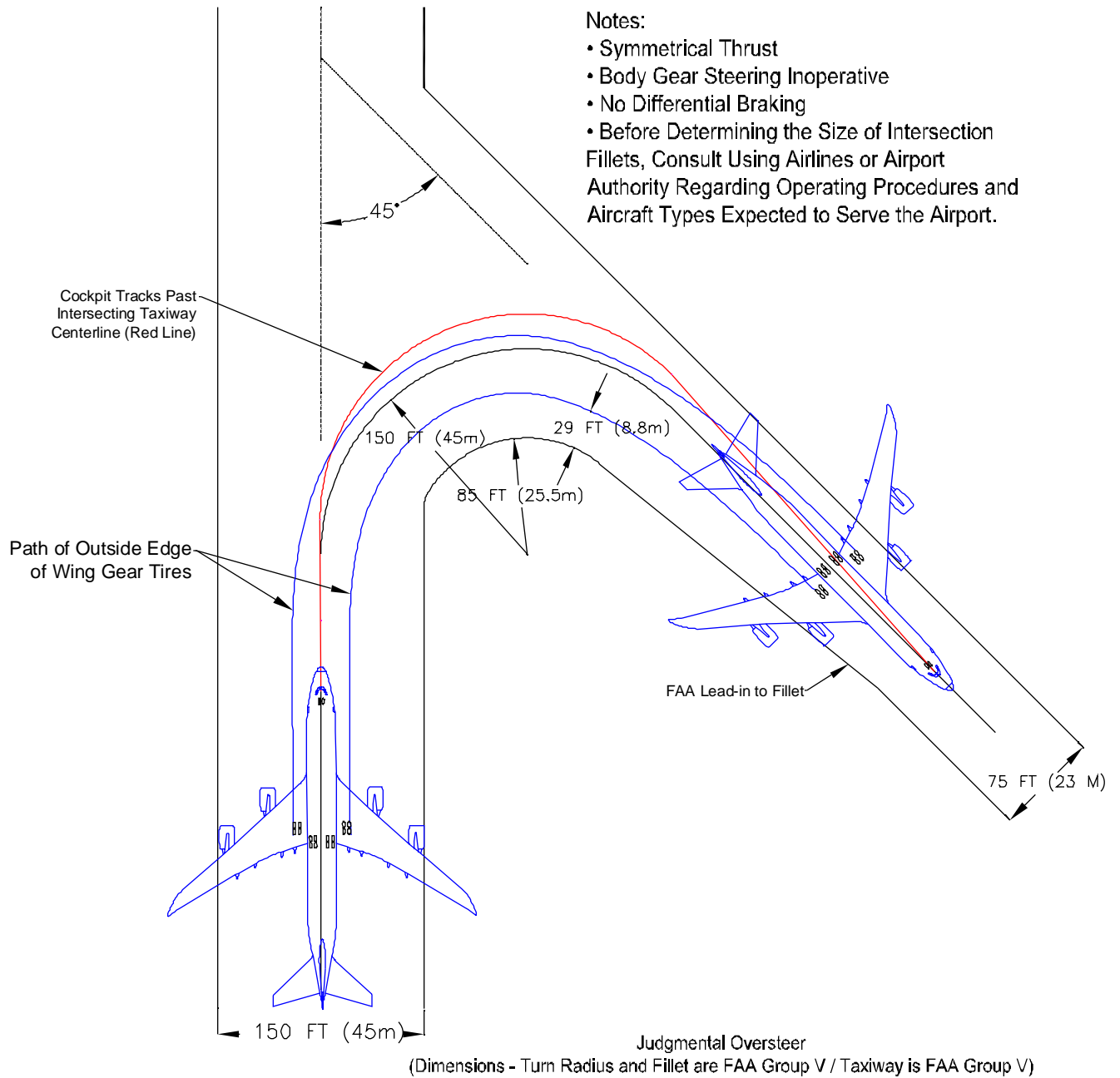

4.5.6 RUNWAY AND TAXIWAY TURNPATHS - RUNWAY-TO-TAXIWAY, MORE THAN 90 DEGREES, JUDGMENTAL OVERSTEER (FAA GROUP V RADIUS TO GROUP V TAXIWAY)

MODEL 747-8F

PRELIMINARY

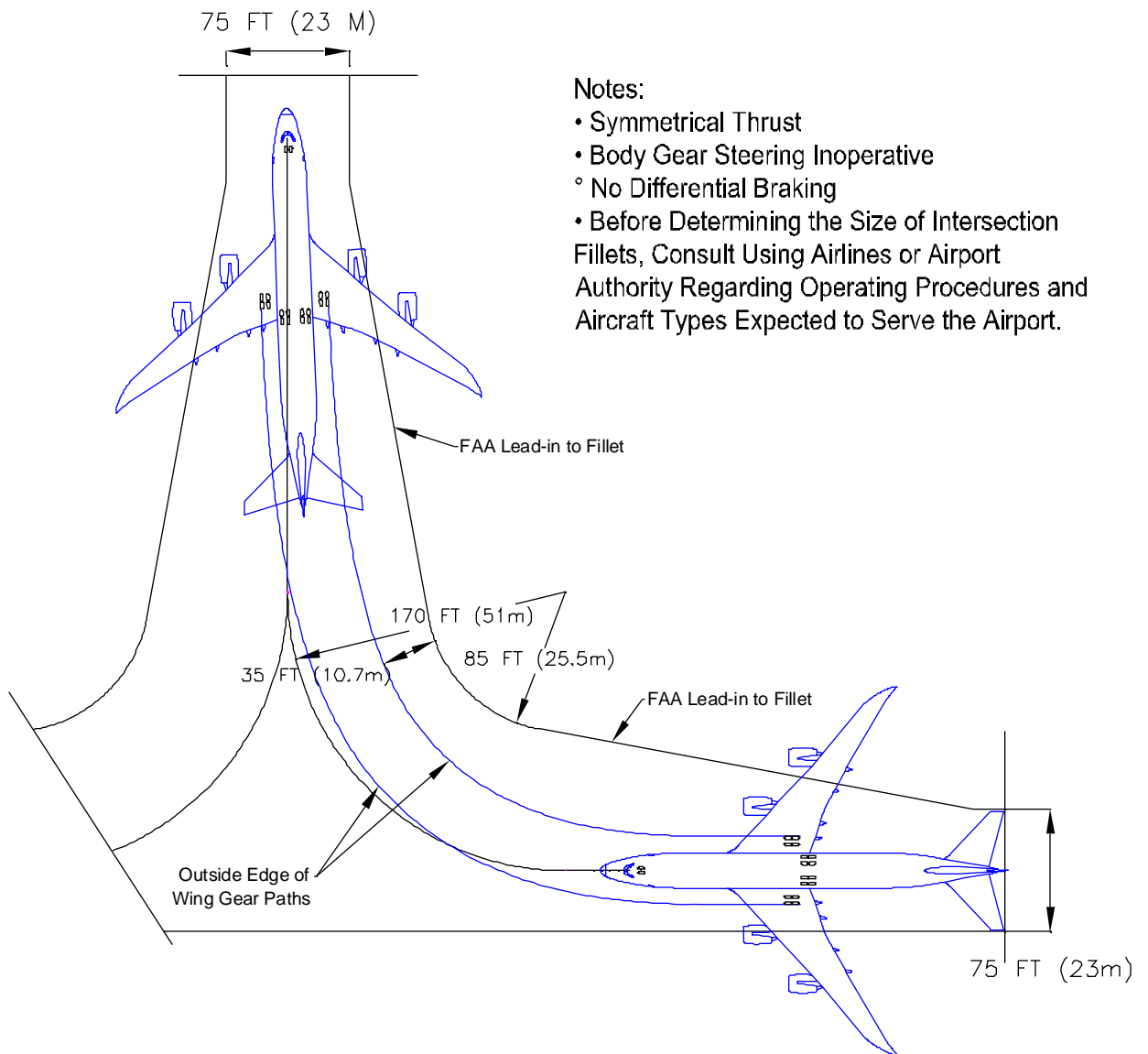

Cockpit Over Centerline Steering
 (Dimensions - Turn Radius and Fillet are FAA Group VI / Taxiways are FAA Group V)

4.5.7 RUNWAY AND TAXIWAY TURNPATHS - TAXIWAY -TO-TAXIWAY, 90 DEGREES, COCKPIT OVER CENTERLINE (FAA GROUP VI RADIUS TO GROUP V TAXIWAYS) MODEL 747-8F

PRELIMINARY

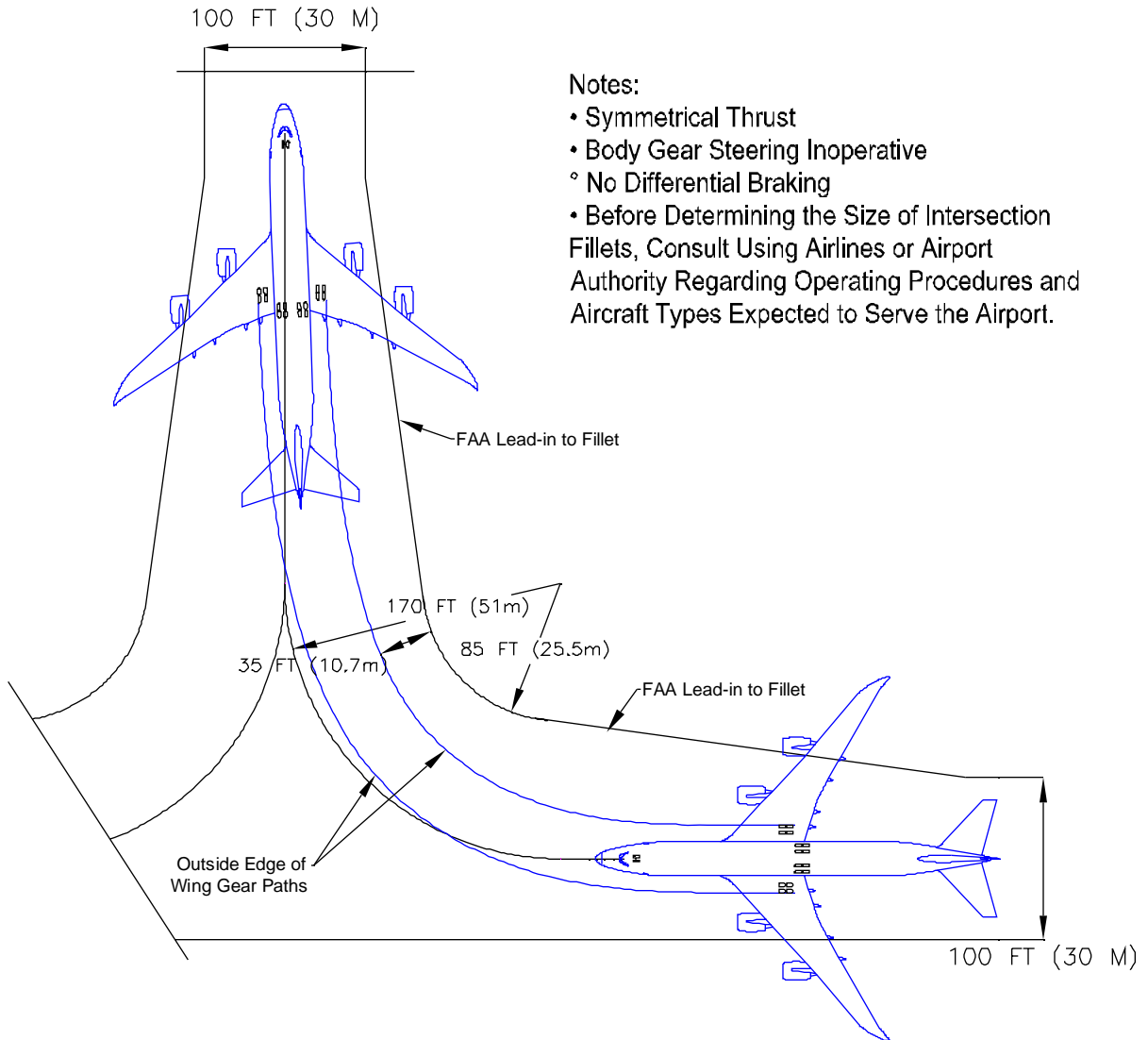

Notes:

- Symmetrical Thrust
- Body Gear Steering Inoperative
- No Differential Braking
- Before Determining the Size of Intersection Fillets, Consult Using Airlines or Airport Authority Regarding Operating Procedures and Aircraft Types Expected to Serve the Airport.

Cockpit Over Centerline Steering
(Dimensions - Turn Radius and Fillet are FAA Group VI / Taxiways are FAA Group VI)

4.5.8 RUNWAY AND TAXIWAY TURNPATHS - TAXIWAY -TO-TAXIWAY, 90 DEGREES, COCKPIT OVER CENTERLINE (FAA GROUP VI RADIUS TO GROUP VI TAXIWAYS) MODEL 747-8F

PRELIMINARY

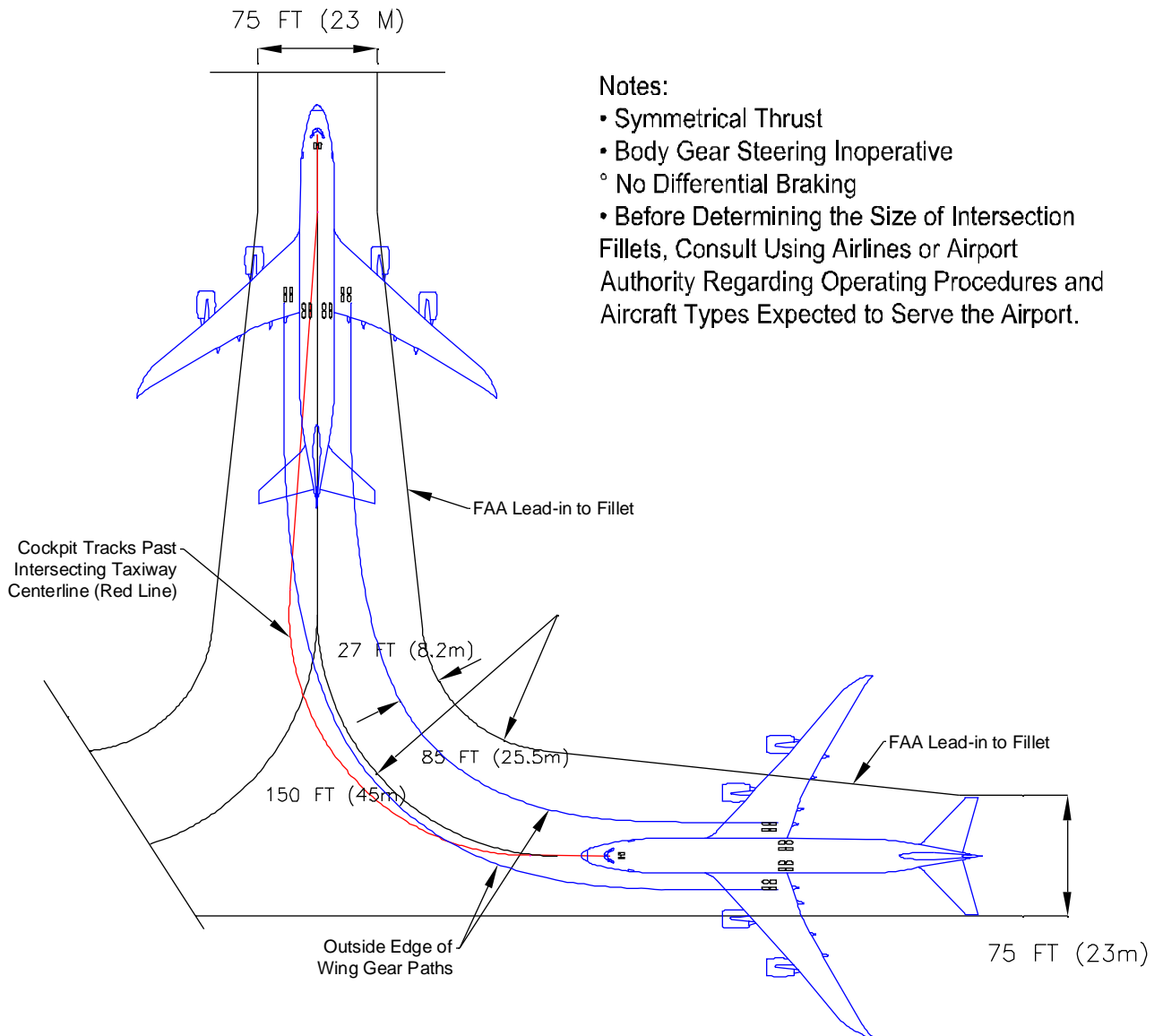

Notes:

- Symmetrical Thrust
- Body Gear Steering Inoperative
- ° No Differential Braking
- Before Determining the Size of Intersection Fillets, Consult Using Airlines or Airport Authority Regarding Operating Procedures and Aircraft Types Expected to Serve the Airport.

Judgmental Oversteering
 (Dimensions - Turn Radius and Fillet are FAA Group V / Taxiways are FAA Group V)

**4.5.9 RUNWAY AND TAXIWAY TURNPATHS - TAXIWAY -TO-TAXIWAY, 90 DEGREES, JUDGMENTAL OVERSTEER (FAA GROUP V RADIUS TO GROUP V TAXIWAY)
 MODEL 747-8F**

PRELIMINARY

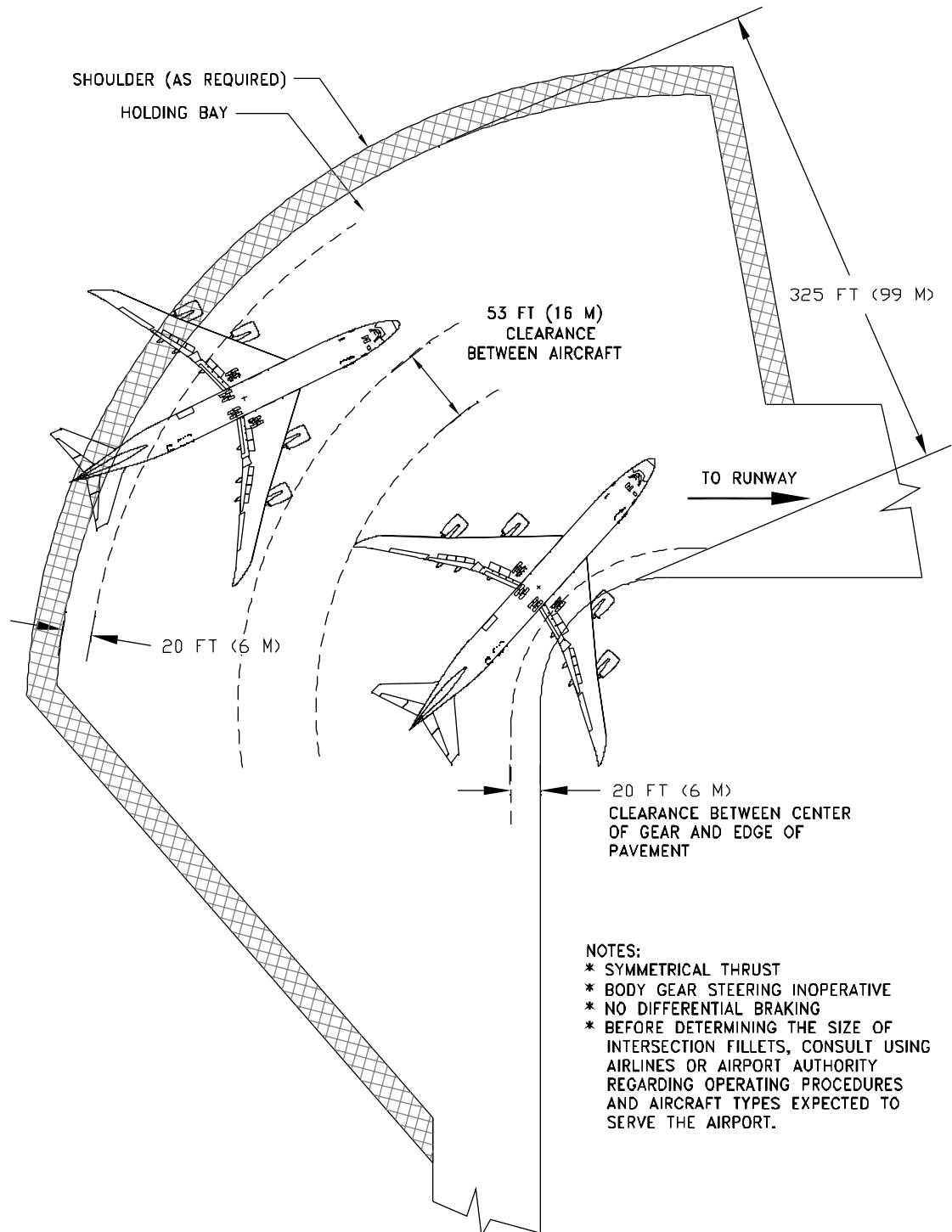

4.6 RUNWAY HOLDING BAY MODEL 747-8F