



# Ground Wireless Systems to support the Boeing 787

## Network Systems

Boeing Commercial Airplanes  
March 2009



# 787 Use of Wireless Technology While on the Ground

---

- The 787 uses wireless (802.11 b/g) technology while at the gate to transfer maintenance data and update the Electronic Flight Bag (EFB). This is referred to as “e-Enabling” and it will allow airlines flying the 787 to operate more efficiently.
- Wireless 802.11 b/g are line of site technologies. Airports have significant RF energy and as such, the time to begin coordinating and planning for the airside antenna system is now.
- Boeing can assist with the development of the wireless system for the airside.
- Boeing is assisting with the development of the standards - ARINC 763, 821 and 822.



# 787 Line of Sight Requirements

Clear line of sight is required between the TWLU Antenna and the airside antenna. The TWLU is mounted on the top of the fuselage just aft (0.9 FT / 0.3m) of the trailing edge of the L1 passenger door. Maximum height of the TWLU antenna is 25.7 FT (7.8m).

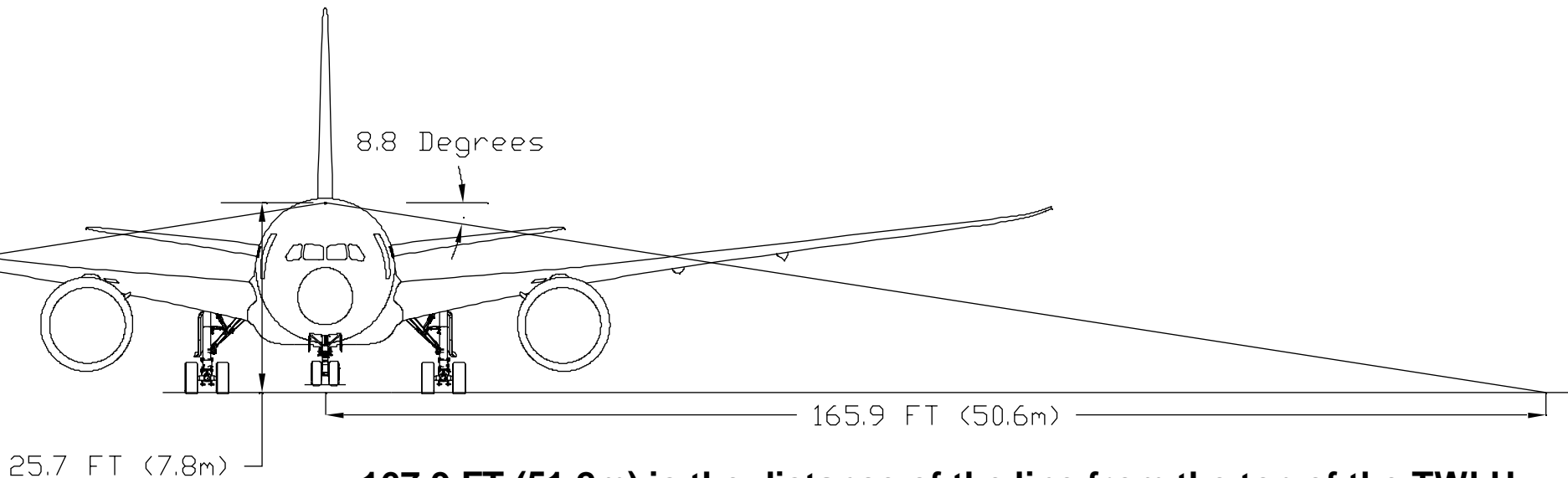

**167.9 FT (51.2m)** is the distance of the line from the top of the TWLU Antenna to the ground which is **165.9 FT (50.6m)** from the aircraft centerline. **8.8°** is the corresponding line of sight angle.

# Authentication Requirements

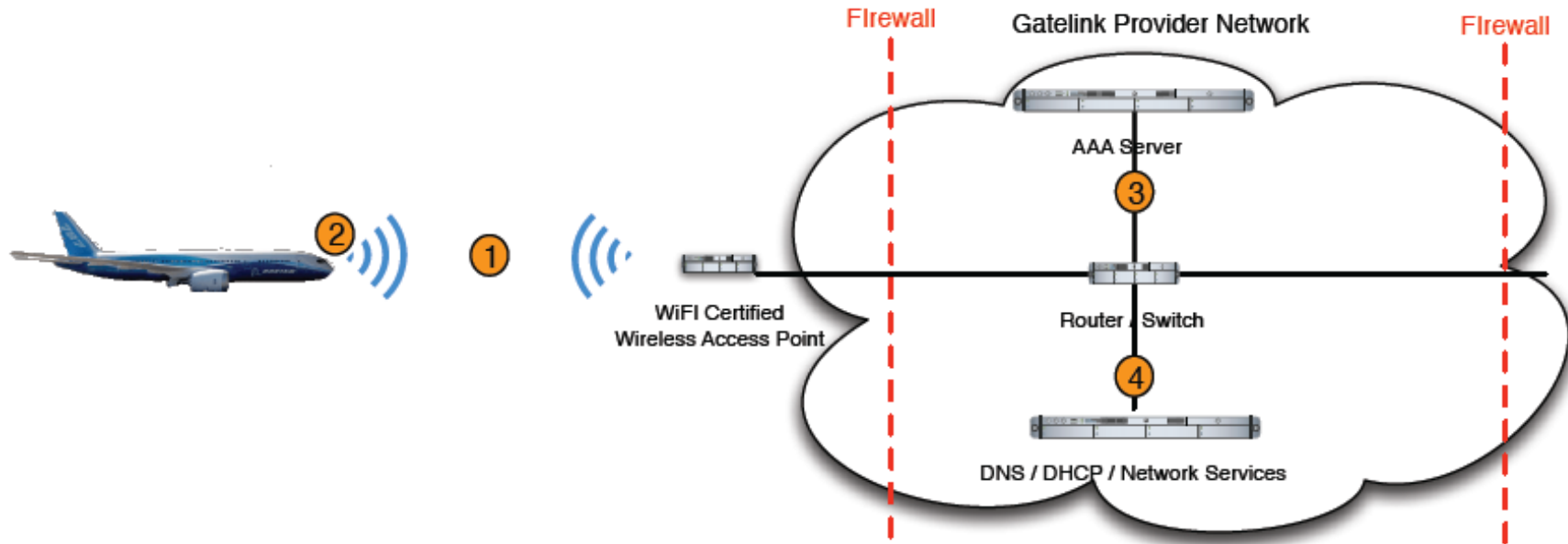

- Upon weight on wheels the 787 attempts to authenticate specific ground access points.
- Information regarding the key configuration requirements and how the 787 authentication occurs requires the signing of a PIA.

# Sectorized & Omni Antennas are Required to Support Terminal, Remote Parking and Other Requirements



# Example of Mapped Coverage by Multiple Antennas

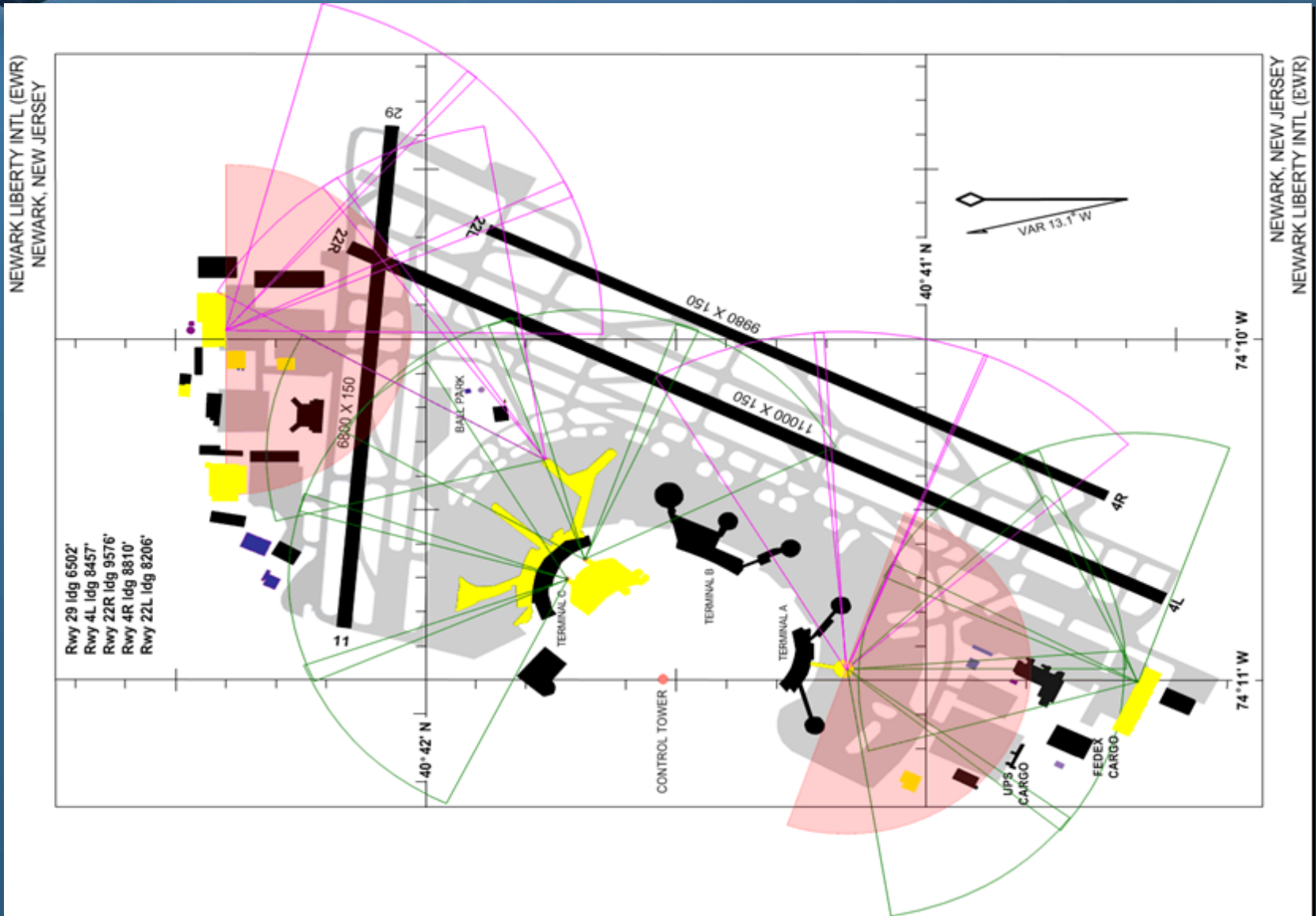



# Implementing Terminal Wireless for the 787

---

- Boeing has produced a document explaining the key configuration requirements for connecting to the 787 with a ground wireless network.
- In order to obtain this document a Proprietary Information Agreement (PIA) must be signed between your company and Boeing.
- If you would like to obtain a copy of this document please contact:  
[787terminalwireless@boeing.com](mailto:787terminalwireless@boeing.com)



# Summary

---

- e-Enabling of the 787 on the ground will allow airlines to operate more efficiently.
- 802.11 b/g are line of site technologies.
- Airports have significant RF energy. The time to begin coordinating and planning is now to determine the location of antennas to support ground operations at both terminal gates and remote parking gates.
- Boeing can assist with the development of the wireless system for the airside. Contact 787 Terminal Wireless at (787terminalwireless@boeing.com).
- Boeing is assisting with the development of the standards - ARINC 763, 821 and 822.