



# BC-17 / C-17A Airport Compatibility

Airport Technology  
Boeing Commercial Airplanes

September 2005

(Minor revisions to ACN charts – Aug 2011)

# Description

The following brochure provides BC-17/C-17 Airport Compatibility data that is accessible by the airports (commercial, joint-use, and military), regulatory agencies and Architectural & Engineering firms to support the operation of the aircraft where it is not typically operated, nor where there is an Air Force presence that can provide technical information. The BC-17 is a commercial variant of the C-17A sharing the same external dimensions. The BC-17 offers new air cargo delivery capabilities ideally matched to the global changes occurring in logistics and manufacturing. Manufacturers and shippers look for time-definite delivery to global markets and emerging markets characterized by minimal transportation infrastructure. Worldwide demand for heavy and outsize goods – including satellites, construction equipment, and power generating equipment – continues to increase. With the BC-17, logistics planners have new options for picking up products closer to the source and delivering them closer to the final destination. The BC-17 uses smaller airports unavailable to today's conventional cargo aircraft. Many emerging countries have large infrastructure development projects (such as power plants and waterways) not situated near existing seaports, major airports, major roads, or railways.

The BC-17/C-17's performance allows for routine operations into and out of small, austere airfields – typically with runways 3,000 to 5,000 FT (914 to 1,524m) long and 90 FT (27.4m) wide.

Specific airport compatibility questions concerning this or other commercial aircraft should be forwarded to:

Airport Technology  
Boeing (Seattle, WA)  
Voice 1-425-237-1004, Fax 1-425-237-2665  
E-mail: [AirportTechnology@boeing.com](mailto:AirportTechnology@boeing.com)

T20431



# General Arrangement

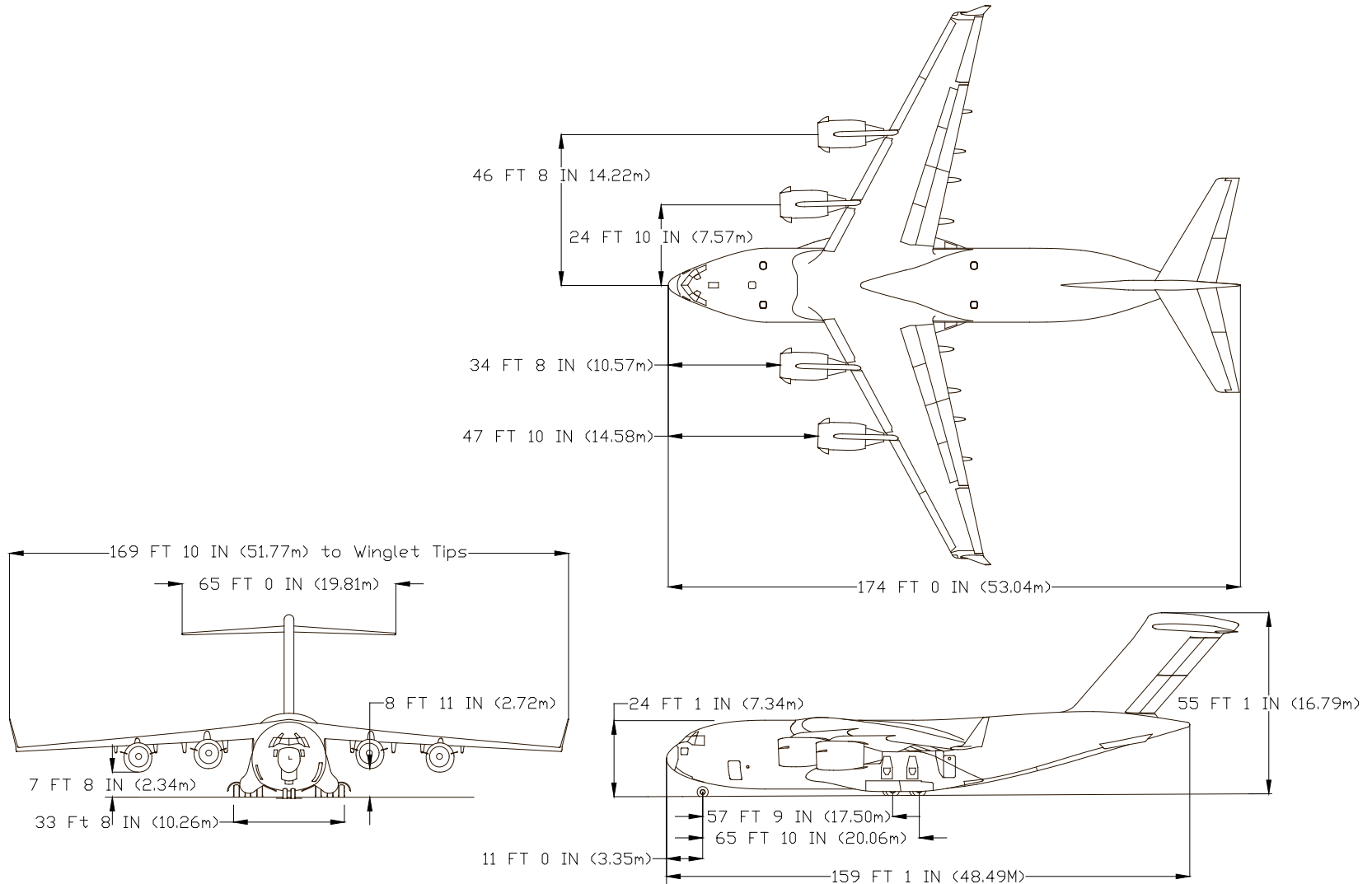

# General Aircraft Characteristics

## Gross Weight Data

|  |            |            |
|--|------------|------------|
| Max Ramp Weight (2.25 g)                                       | 586,000 lb | 265,805 kg |
| Max Takeoff Gross Weight                                       | 585,000 lb | 265,352 kg |
| Zero Fuel Weight (Max Design)                                  | 477,400 lb | 216,508 kg |
| Operating Empty Weight   | 282,500 lb | 128,118 kg |
| Maximum Payload  | 164,900 lb | 74,785 kg  |
| Max Landing Gross Weight                                       | 585,000 lb | 265,352 kg |
| Design Landing Gross Weight<br>at Max Sink Rate of 12.5 ft/sec | 435,800 lb | 197,642 kg |
| Usable Fuel Capacity   | 36,546 gal | 138,342 L  |

## General Characteristics

|                                 |             |             |
|---------------------------------|-------------|-------------|
| Max Range Cruise Speed          | 0.74 M      | 0.74 M      |
| Typical Long Range Cruise       | 0.76 M      | 0.76 M      |
| Engine Thrust (each)            | 40,440 lb   | 179.9 kN    |
| Service Ceiling                 | 45,000 ft   | 13,716 m    |
| Airport Design Group            | FAA Group V | ICAO Code E |
| Aircraft Rescue & Fire Fighting | FAA Index D | ICAO Cat 8  |

# Minimum Turning Radii

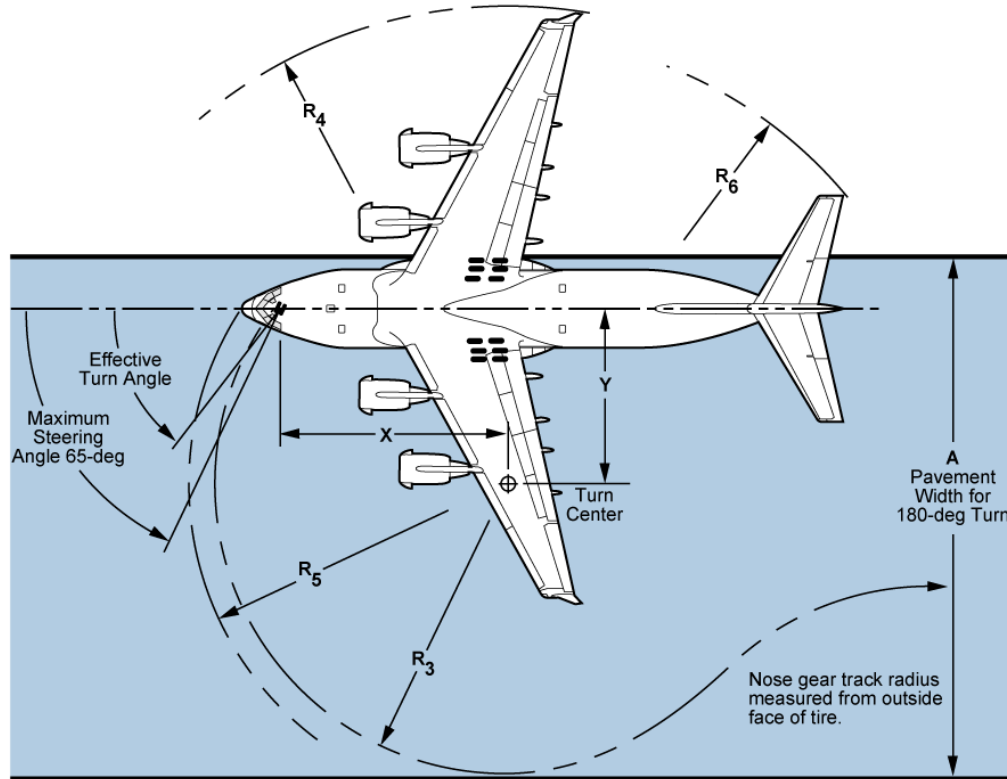

Note: Through use of reverse thrust, the aircraft is capable of accomplishing a 180 degree turnaround using a “three point turn” procedure within a 90 ft pavement width (includes a 5 ft margin on either side of runway)

| Steering Input (deg)  | Nose Tire Scrub (deg) | Effective Steering (deg) | X (ft) | Y (ft) | A (ft) | R <sub>3</sub> (ft) | R <sub>4</sub> (ft) | R <sub>5</sub> (ft) | R <sub>6</sub> (ft) |
|---|-----------------------|--------------------------|--------|--------|--------|---------------------|---------------------|---------------------|---------------------|
| Normal Turn Recommended for Routine Operations Using Symmetric Thrust and No Differential Braking |                       |                          |        |        |        |                     |                     |                     |                     |
| 30  | 1.4                   | 28.6                     | 62.1   | 114.0  | 262.5  | 131.7               | 200.5               | 135.4               | 177.7               |
| 40  | 2.4                   | 37.6                     | 62.1   | 80.6   | 201.1  | 103.6               | 167.4               | 108.8               | 151.4               |
| 50  | 4.1                   | 45.9                     | 62.1   | 60.2   | 165.5  | 88.4                | 147.3               | 94.7                | 136.8               |
| 60  | 7.9                   | 52.1                     | 62.1   | 48.4   | 145.8  | 80.6                | 135.6               | 87.7                | 129.0               |
| 65  | 11.8                  | 53.2                     | 62.1   | 46.4   | 142.6  | 79.4                | 133.7               | 86.6                | 127.8               |

# Runway-To-Taxiway Turnpaths – 90°

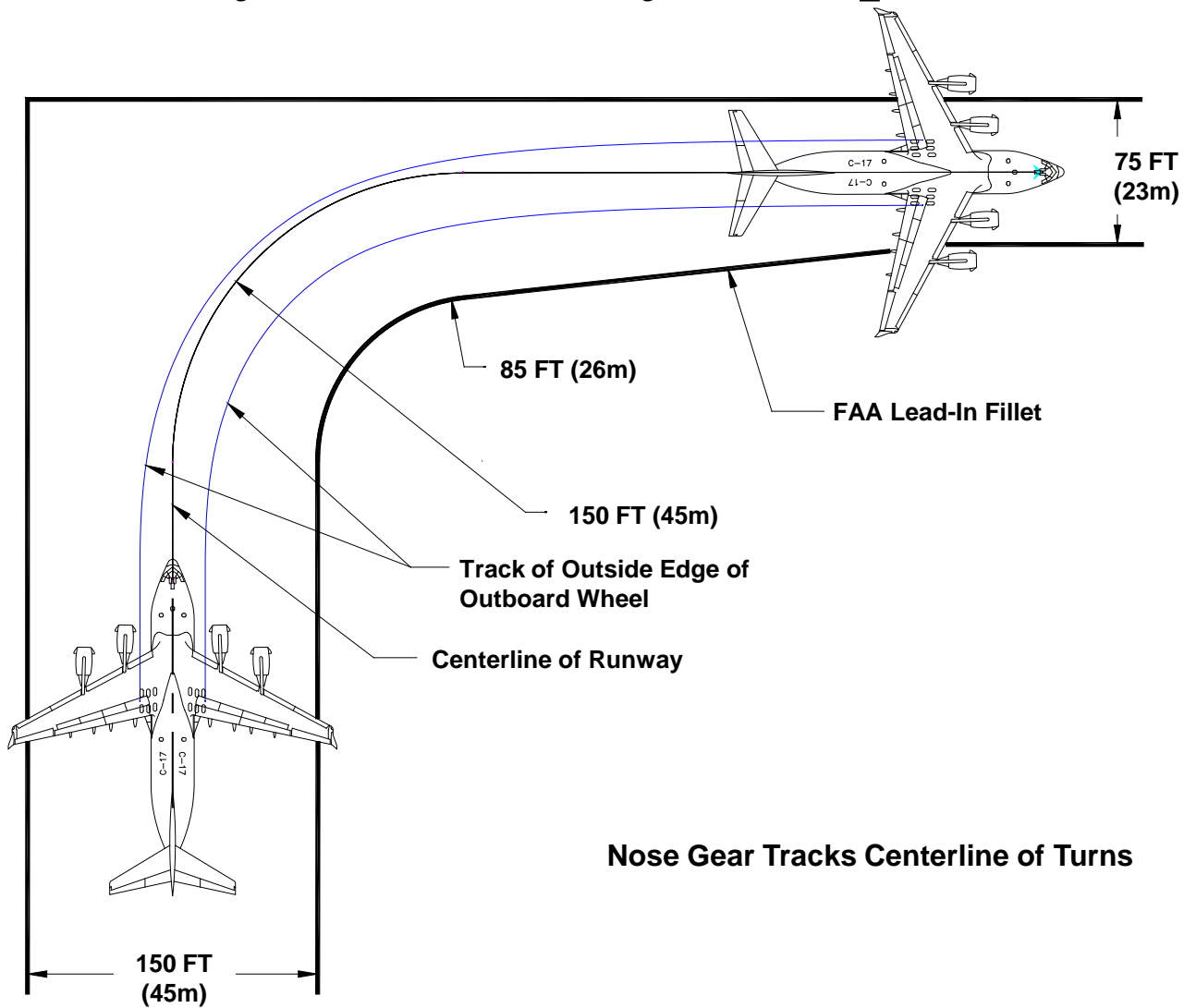

# Taxiway-To-Taxiway Turnpaths – 90°

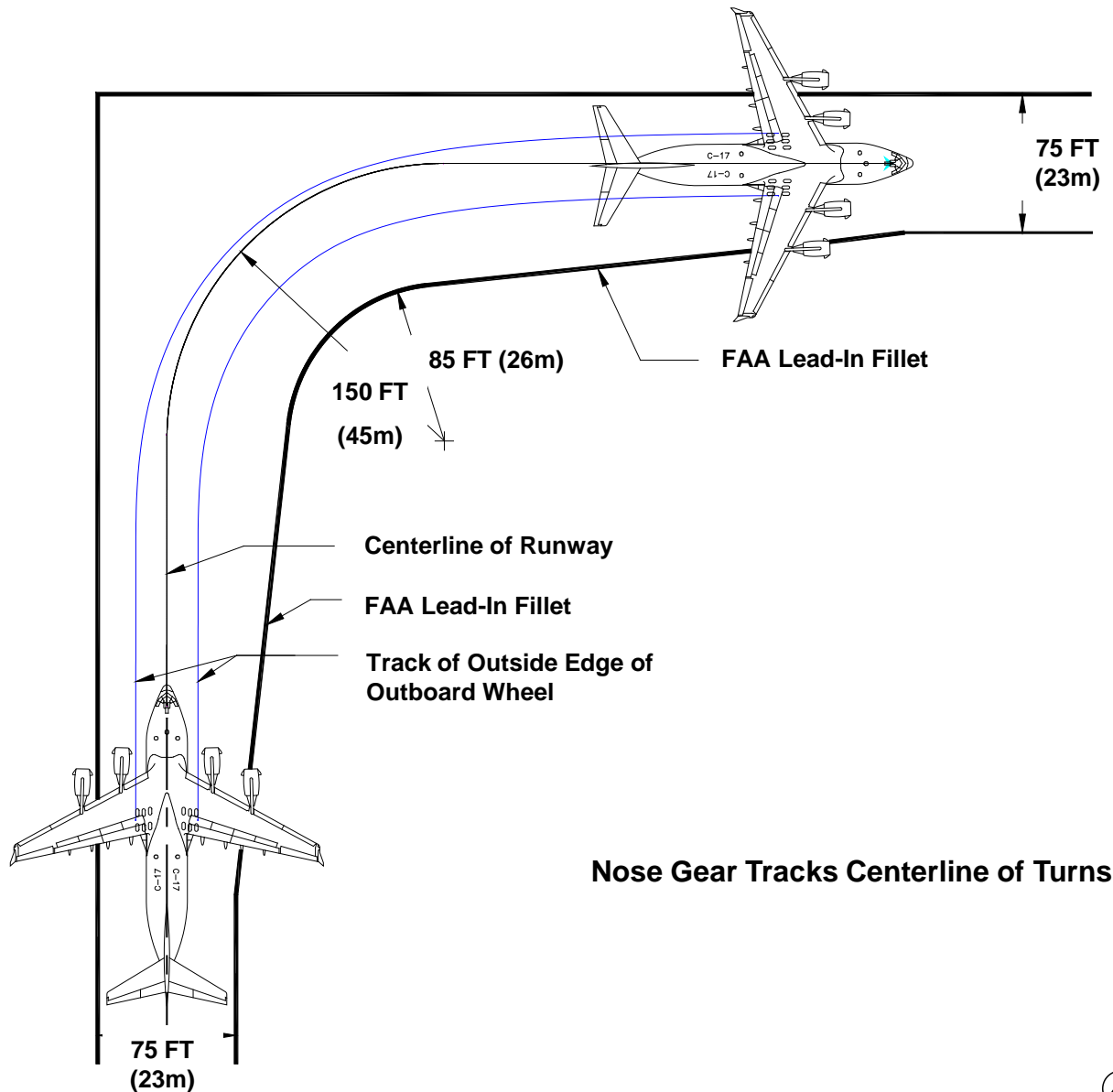

# Ground Servicing Connections

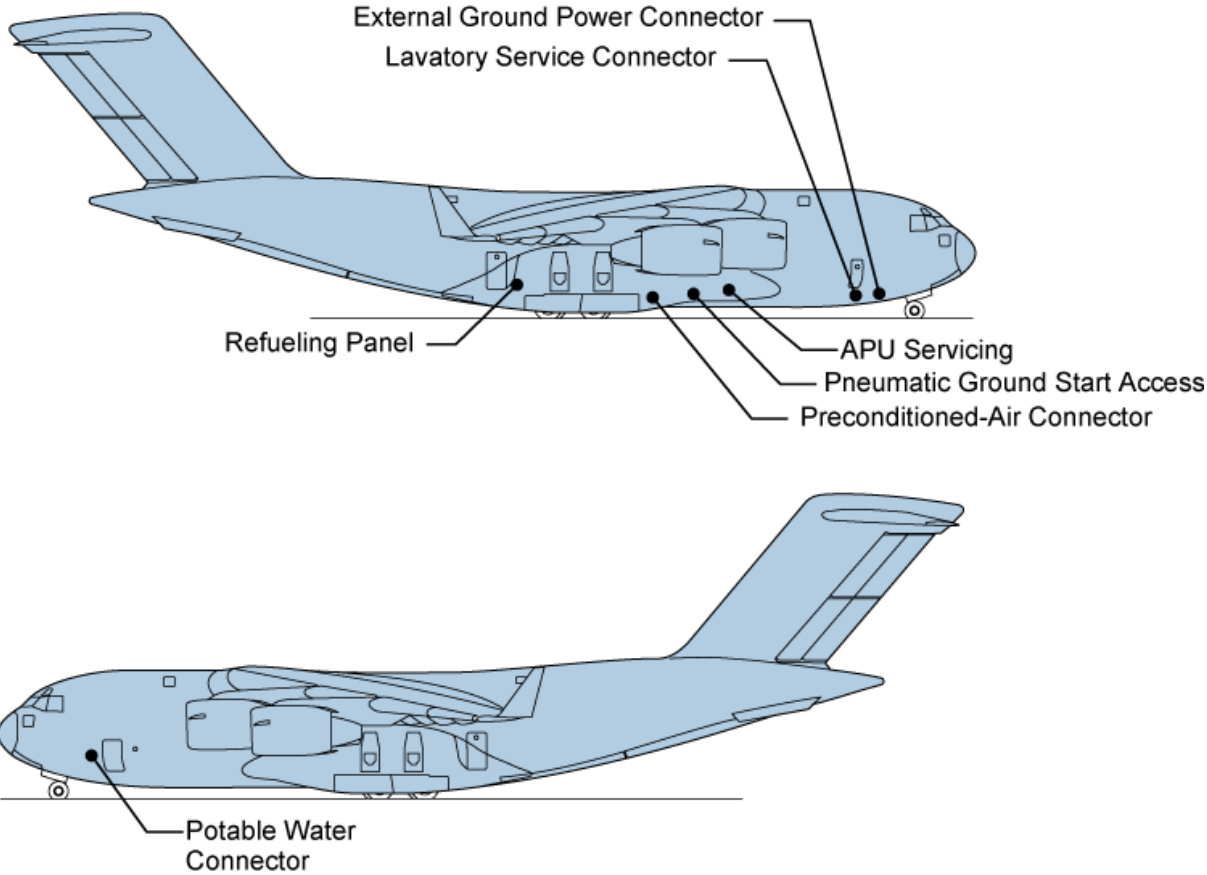

Note: All ground servicing connections shown can be accessed by personnel standing on the ground.



# Intake and Exhaust Danger Areas

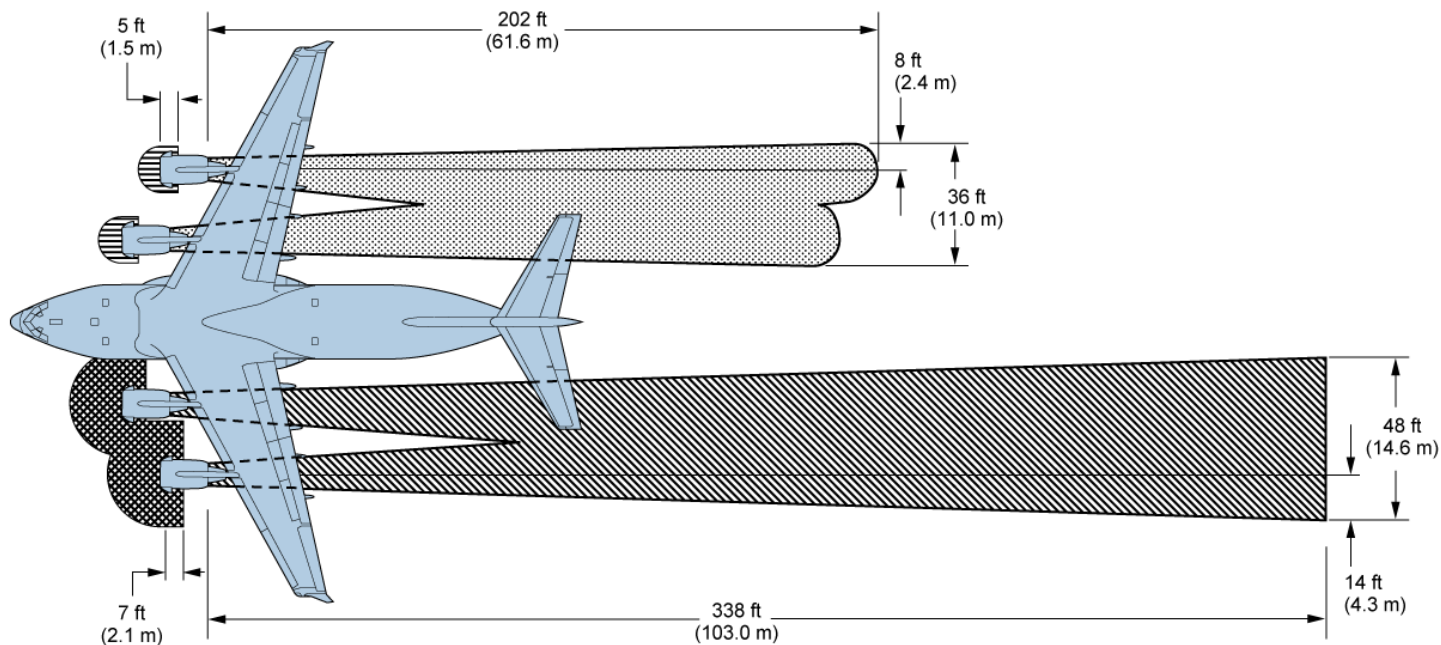

## LEGEND

### Take Off Thrust



Intake 16 ft (4.9 m) radius



**Blast:**  
 200 mph (322 km/hr) at 115 ft (35.1 m) or less  
 136 mph (219 km/hr) at 170 ft (51.8 m)  
 68 mph (109 km/hr) at 338 ft (103.0 m)



**Temp:**  
 200°F (93°C) at 65 ft (19.8 m)  
 150°F (66°C) at 95 ft (29.0 m)  
 100°F (38°C) at 202 ft (61.6 m)

### Idle Thrust



Intake 9 ft (2.7 m) radius

**Blast:** 136 mph (219 km/hr) at 28 ft (8.5 m)  
 68 mph (109 km/hr) at 95 ft (29.0 m)

**Temp:** 125°F (52°C) at 22 ft (6.7 m)  
 100°F (38°C) at 50 ft (15.2 m)

# Landing Gear Footprint

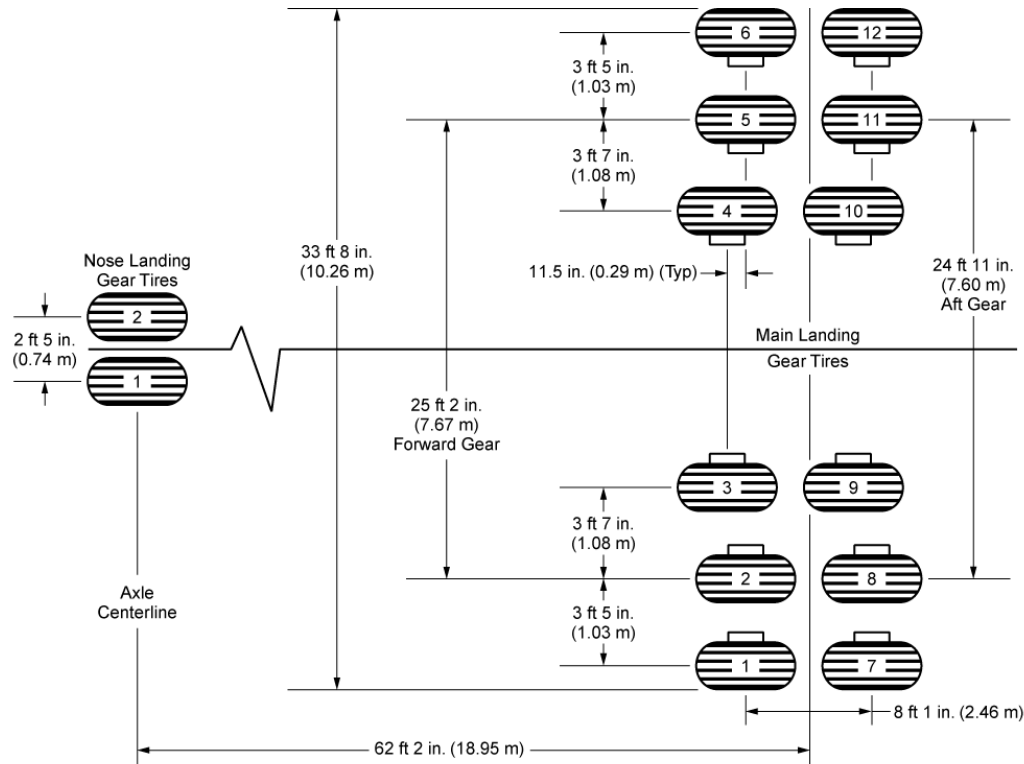

| Tire Data                 | Nose   | Main   |
|---------------------------|--|--|
| Size                      | 40 x 16 – 14                                   | 50 x 21 – 20                                     |
| Typical Load Distribution | 8%   | 92%  |
| Inflation                 |  |  |
| Normal                    | 160 psi<br>(1,103 kPa)                         | 144 psi<br>(993 kPa)                             |
| Substandard Airfield*     | 100 psi<br>(689 kPa)                           | 110 psi<br>(758 kPa)                             |
| Nominal Area              |  |  |
| At Maximum Weight         | 150 in. <sup>2</sup><br>(968 cm <sup>2</sup> ) | 320 in. <sup>2</sup><br>(2,065 cm <sup>2</sup> ) |
| At Empty Weight           | 70 in. <sup>2</sup><br>(452 cm <sup>2</sup> )  | 150 in. <sup>2</sup><br>(968 cm <sup>2</sup> )   |
| Rated Load                | 29,200 lb<br>(13,245 kg)                       | 49,000 lb<br>(22,226 kg)                         |

\*Minimum air pressures with maximum landing weight of 435,000 lb (197,313 kg)

# Aircraft Classification Numbers – ACN/PCN

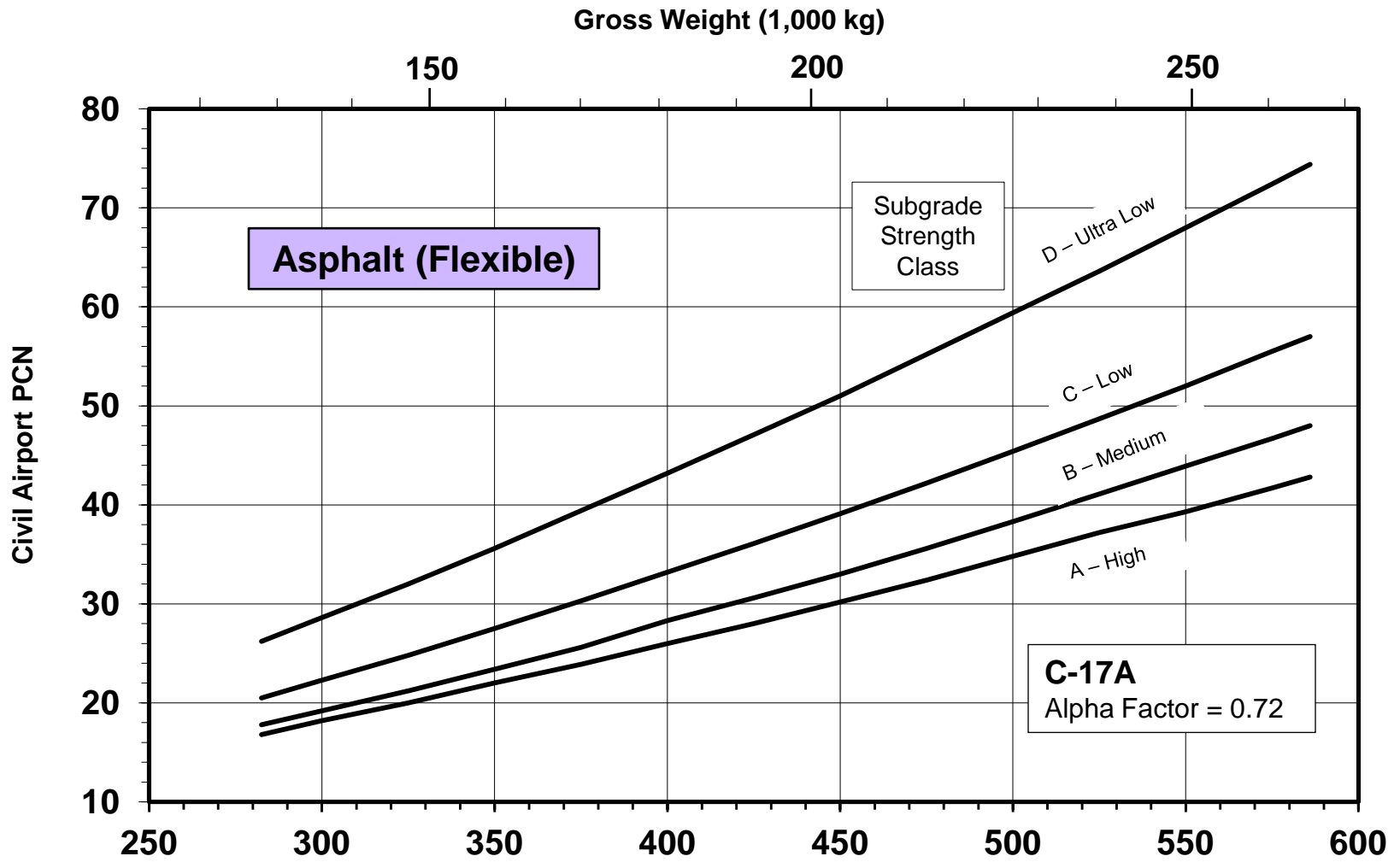

Note - This chart revised August 2011 in consultation with Boeing's C-17 Systems Integrity

Gross Weight (1,000 lb)



# Aircraft Classification Numbers – ACN/PCN

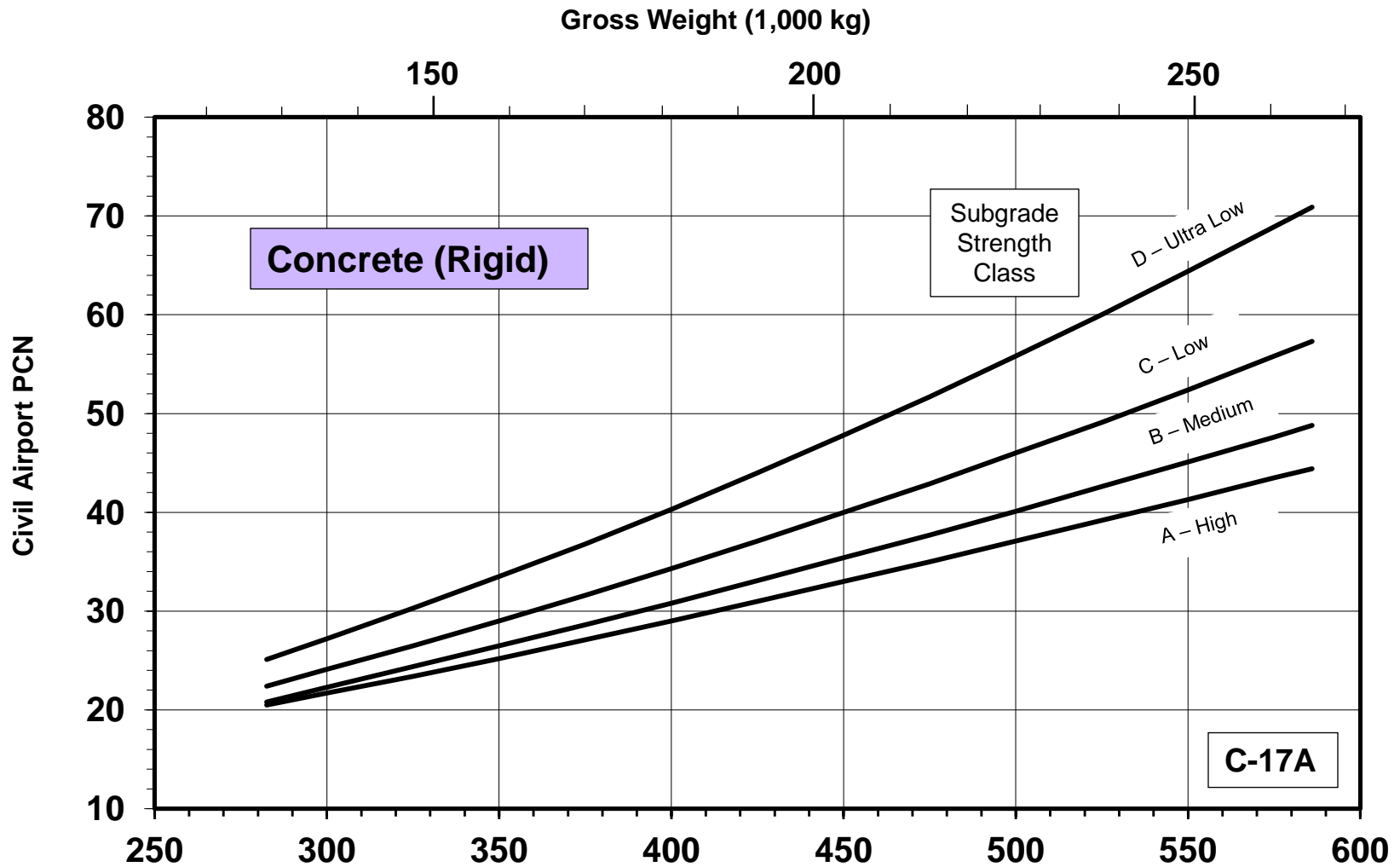

Note - This chart revised August 2011 in consultation with Boeing's C-17 Systems Integrity

Gross Weight (1000 lb)



# LCN (ICAO) Method

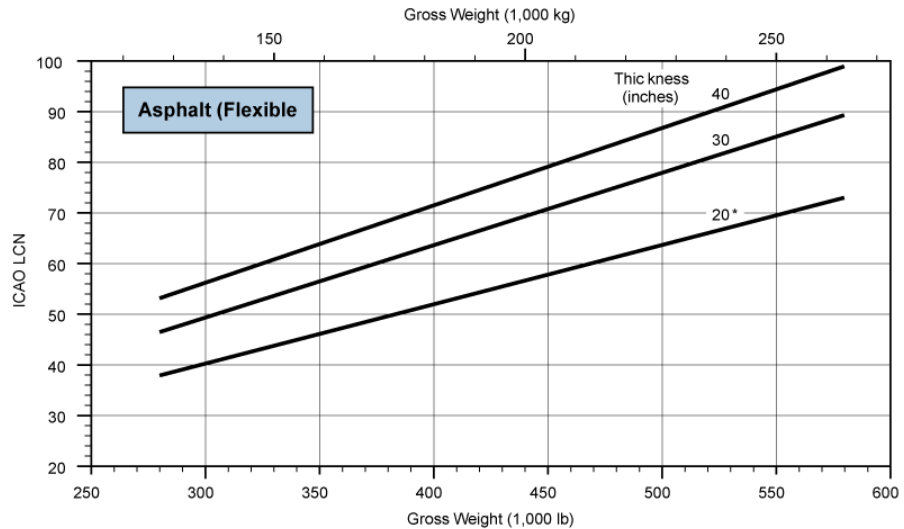
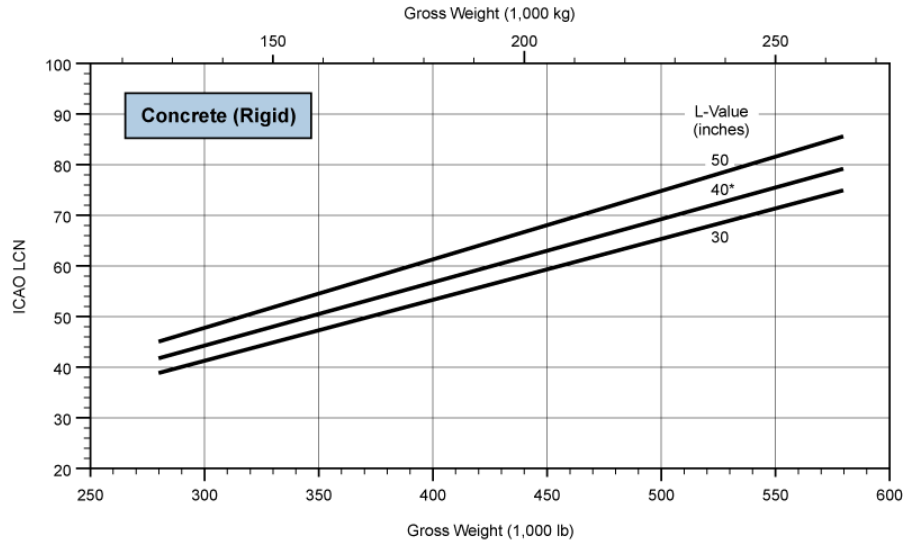

- Note:
1. Use typical L-value or thickness, denoted by asterisk, when actual value is unknown.
  2. Increase allowable ICAO LCN by 25% for overload operations approximately one flight per day.



# LCN/CG Method

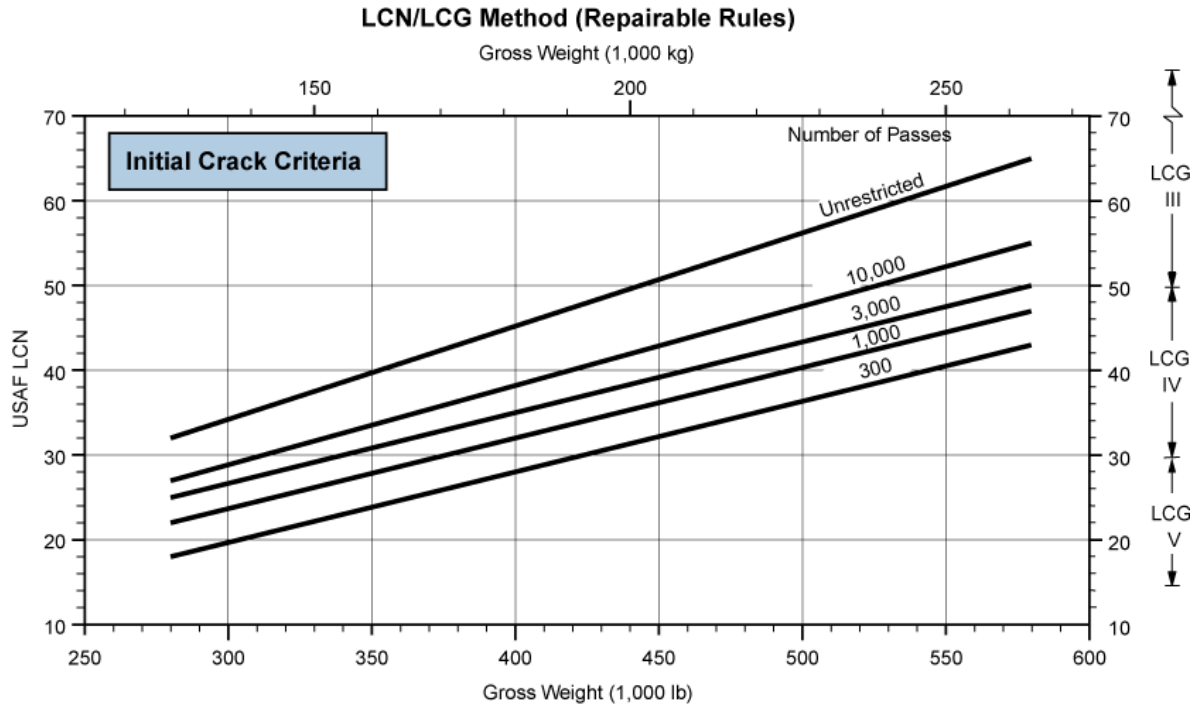

# Aircraft Rescue & Fire Fighting Information

Aircraft rescue and fire fighting information for the C-17, such as shown in the adjacent chart, is available at the following website:

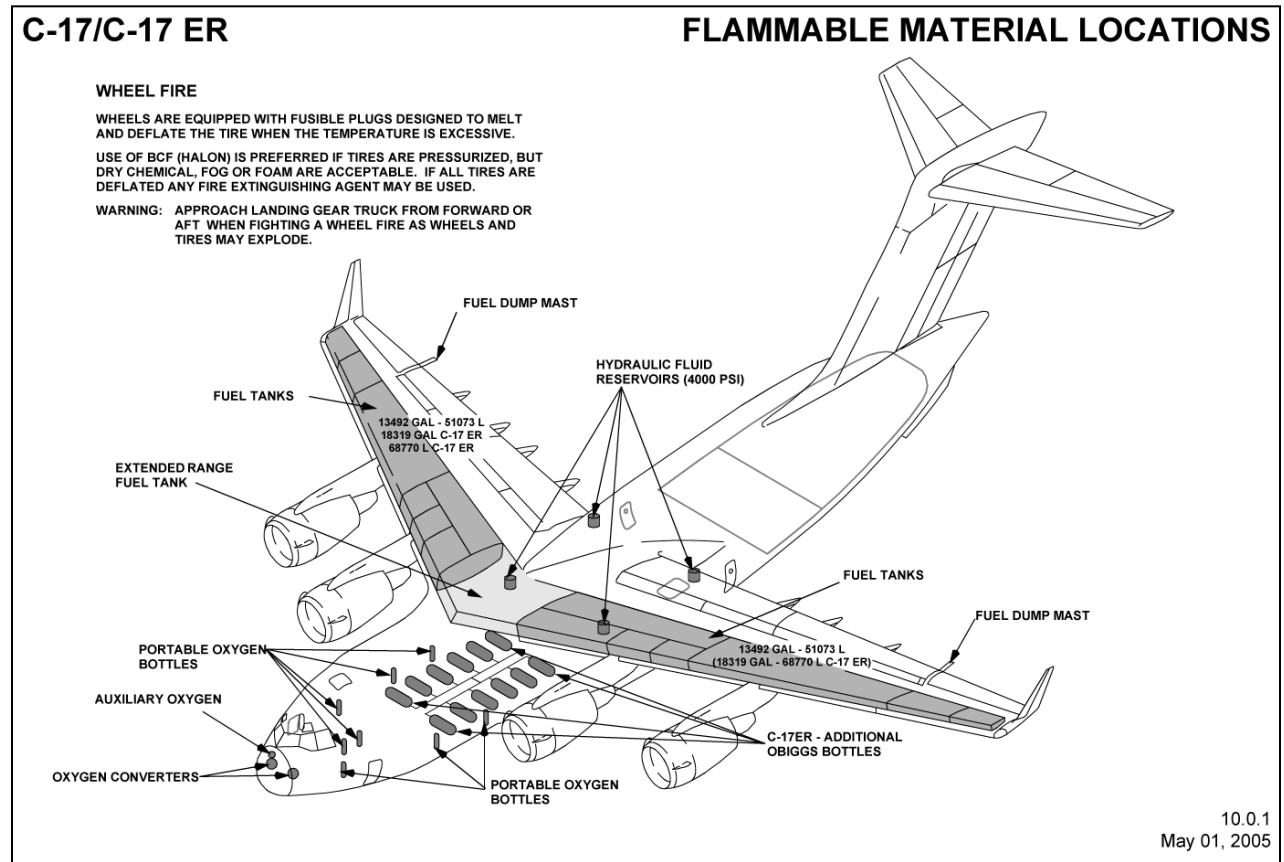

<http://www.boeing.com>