

2.0 AIRPLANE DESCRIPTION

2.1 General Airplane Characteristics

2.2 General Airplane Dimensions

2.3 Ground Clearances

2.4 Interior Arrangements

2.5 Passenger Cabin Cross Section

2.6 Lower Compartments (No Containers)

2.7 Door Clearances

2.0 AIRPLANE DESCRIPTION

2.1 General Airplane Characteristics -- MD-80 (Definitions Refer to Items in Figure 2.1).

Maximum Ramp Weight. Maximum weight authorized for ground maneuver by applicable government regulations, including taxi and runup fuel. Also designated in some manuals as maximum design taxi weight.

Maximum Landing Weight. Maximum weight authorized at touchdown by the applicable government regulations.

Maximum Takeoff Weight. Maximum weight authorized at takeoff brake release by the applicable government regulations and excludes taxi and runup fuel.

Operating Weight Empty. Weight of structure, power plant, furnishings, systems, unusable fuel and other unusable propulsion agents, and other items of equipment that are considered an integral part of a particular aircraft configuration. Also included are certain standard items, personnel, equipment, and supplies necessary for full operation, excluding fuel and payload. Described as "Operating Empty Weight" in some manuals.

Zero Fuel Weight. Maximum airplane weight less usable fuel, engine injection fluid, and other consumable propulsion agents. It may include usable fuel in specified tanks when carried in lieu of payload. The addition of usable and consumable items to the Zero Fuel Weight must be in accordance with the applicable government regulations so that airplane structure and airworthiness requirements are not exceeded.

Maximum Structural Payload. Consists of the maximum design payload weight of passengers, passenger baggage and/or cargo.

Maximum Seating Capacity. The maximum number of passengers specifically certified or anticipated for certification.

Maximum Cargo Volume. The maximum space available for cargo.

Usable Fuel Capacity. The volume of fuel carried for a particular operation, less drainable unusable fuel and trapped fuel remaining after a fuel runout test has been accomplished.

		MODEL MD-81	MODEL MD-82, -88	MODEL MD-83*	MODEL MD-87	MODEL MD-87*
MAXIMUM RAMP WEIGHT	POUNDS	141,000	150,500	161,000	141,000	150,500
	KILOGRAMS	63,958	68,266	73,028	63,957	68,266
MAXIMUM LANDING WEIGHT	POUNDS	128,000	130,000	139,500	128,000	130,000
	KILOGRAMS	58,061	58,967	63,276	58,060	58,967
MAXIMUM TAKEOFF WEIGHT	POUNDS	140,000	149,500	160,000	140,000	149,500
	KILOGRAMS	63,504	67,812	72,575	63,503	67,812
OPERATING WEIGHT EMPTY	POUNDS	77,888	77,976	79,686	73,274	74,880
	KILOGRAMS	35,330	35,369	36,145	33,237	33,965
ZERO FUEL WEIGHT	POUNDS	118,000	122,000	122,000	112,000	112,000
	KILOGRAMS	53,525	55,338	55,338	50,802	50,802
MAXIMUM STRUCTURAL PAYLOAD	POUNDS	40,112	44,024	42,314	38,726	37,120
	KILOGRAMS	18,195	19,969	19,193	17,566	16,837
MAXIMUM SEATING CAPACITY	PASSENGERS	172	172	172	139	139
MAXIMUM CARGO VOLUME	CUBIC FEET	1,253	1,253	1,013	938	695
	CUBIC METERS	35.5	35.5	28.7	26.6	19.7
USABLE FUEL CAPACITY (6.7 LB PER GAL)	U.S. GALLONS	5,846	5,846	6,981	5,845	6,980
	LITERS	22,129	22,129	26,426	22,126	26,422
	POUNDS	39,168	39,168	46,773	39,162	46,766
	KILOGRAMS	17,766	17,766	21,216	17,764	21,213

*WITH 1,130-GALLON FUSELAGE AUXILIARY FUEL TANKS

2.1 GENERAL AIRPLANE CHARACTERISTICS MODEL MD-80 SERIES

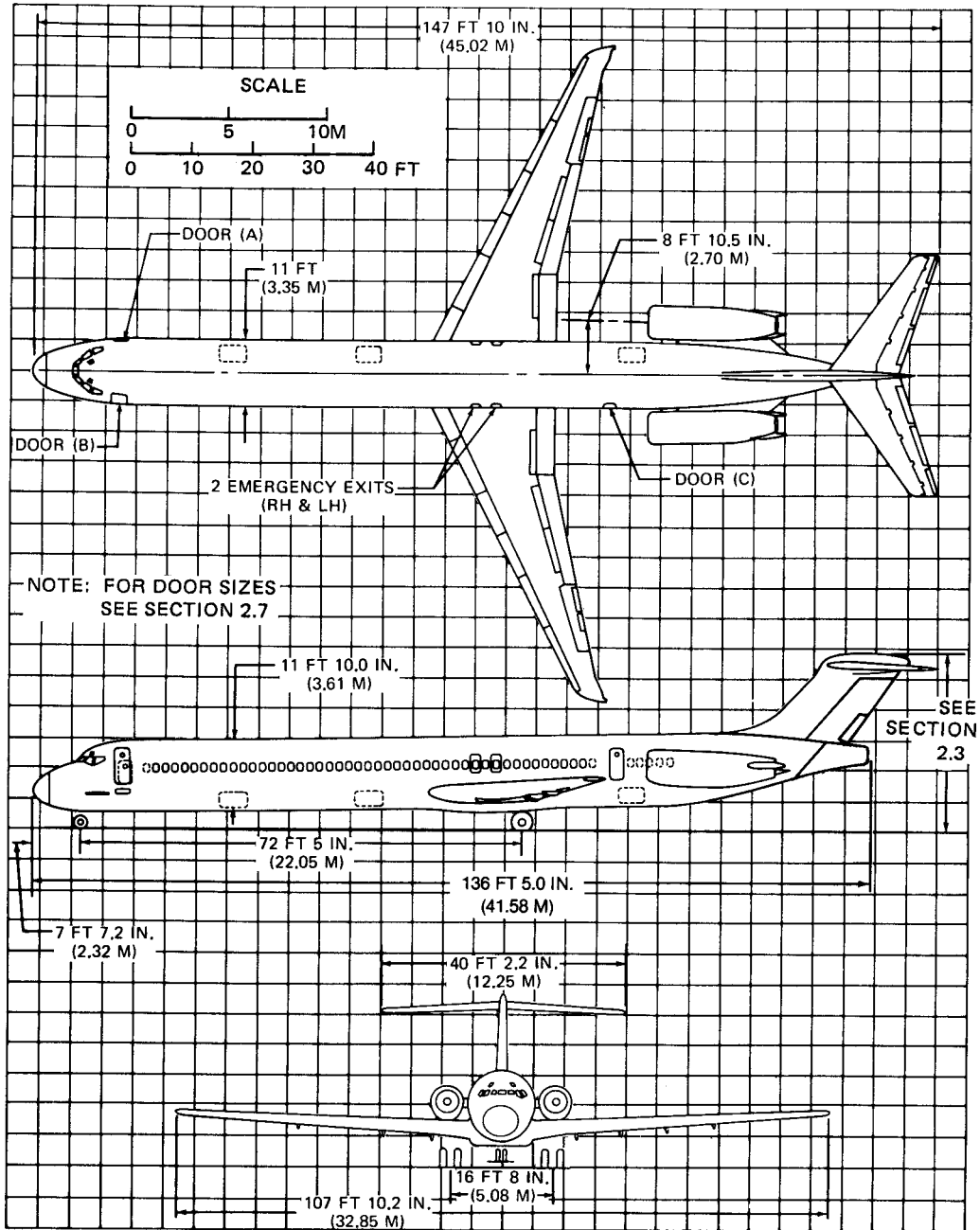

2.2 GENERAL AIRPLANE DIMENSIONS MODEL MD-81, -82, -83, AND -88

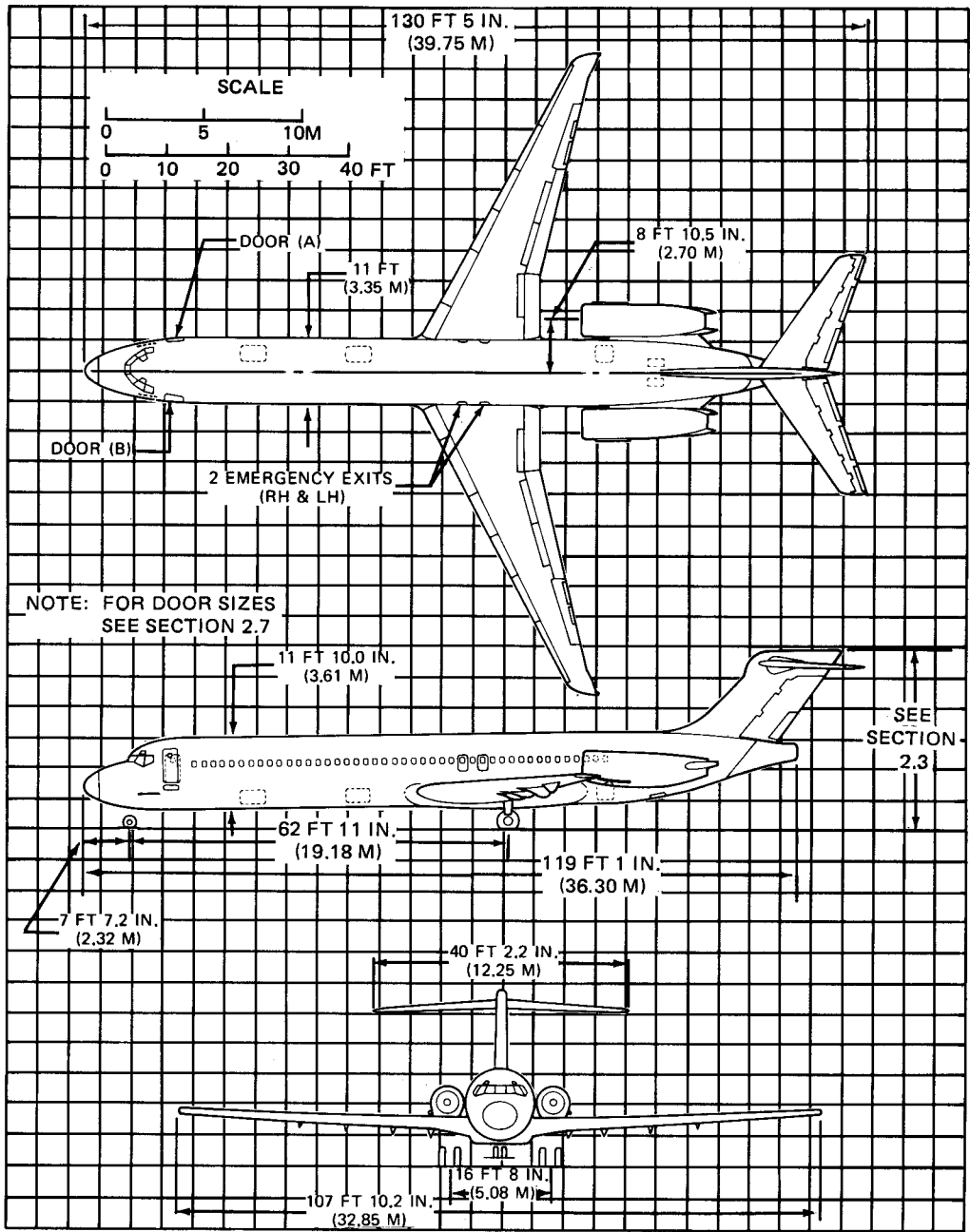

2.2 GENERAL AIRPLANE DIMENSIONS MODEL MD-87

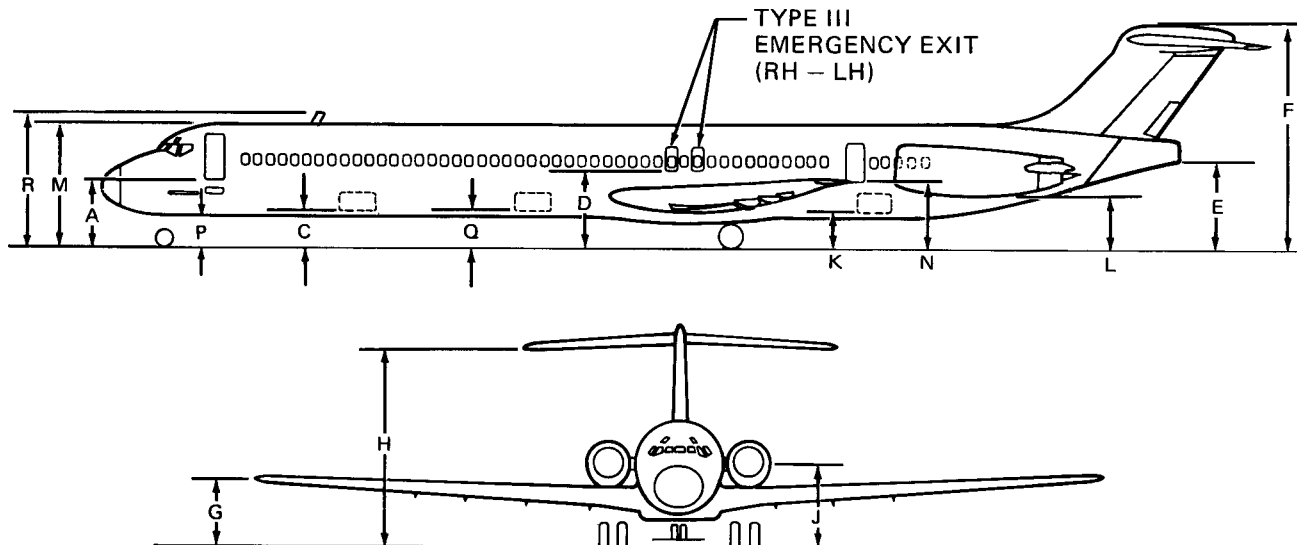

VERTICAL CLEARANCES				
	MAXIMUM		MINIMUM	
	FT - IN.	METERS	FT - IN.	METERS
A	7 - 10	2.4	7 - 3	2.2
B	-	-	-	-
C	4 - 3	1.3	3 - 7	1.1
D	10 - 2	3.1	9 - 9	3.0
E	12 - 1	3.7	11 - 5	3.5
F	30 - 2	9.2	29 - 7	9.0
G	9 - 1	2.8	8 - 7	2.6
H	27 - 6	8.4	26 - 9	8.2
J	11 - 8	3.6	11 - 2	3.4
K	5 - 5	1.7	4 - 9	1.4
L	8 - 2	2.5	7 - 6	2.3
M	15 - 7	4.8	15 - 1	4.6
N	9 - 3	2.8	8 - 10	2.7
P	3 - 7	1.1	3 - 0	0.9
Q	4 - 8	1.4	4 - 0	1.2
R	17 - 1	5.2	16 - 7	5.0

- VALUES SHOWN ARE FOR CERTIFIED WEIGHTS AND CG LIMITS SPECIFIED FOR GROUND OPERATIONS.
- VALUES APPLY TO STATIC AIRCRAFT ON A FLAT, LEVEL SURFACE.
- IT IS RECOMMENDED THAT ± 3 INCHES BE ALLOWED FOR VERTICAL EXCURSIONS DUE TO LOADING, VARYING STRUT AND TIRE INFLATIONS, PAVEMENT UNEVENNESS, ETC.

2.3 GROUND CLEARANCES MODEL MD-81, -82, -83, AND -88

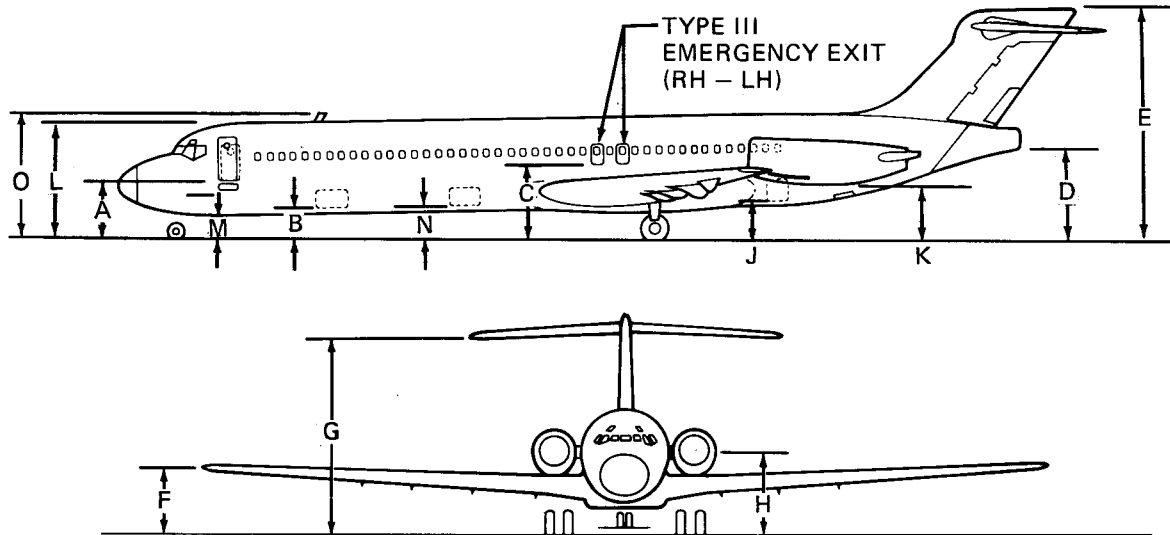

VERTICAL CLEARANCES				
	MAXIMUM		MINIMUM	
	FT - IN.	METERS	FT - IN.	METERS
A	7 - 9	2.4	7 - 3	2.2
B	4 - 1	1.3	3 - 8	1.1
C	10 - 3	3.1	9 - 10	3.0
D	12 - 7	3.8	11 - 8	3.6
E	31 - 2	9.5	30 - 4	9.2
F	9 - 3	2.8	8 - 8	2.6
G	28 - 1	8.6	27 - 2	8.3
H	11 - 8	3.6	11 - 1	3.4
J	5 - 5	1.6	4 - 10	1.5
K	8 - 1	2.5	7 - 6	2.3
L	15 - 8	4.8	15 - 2	4.6
M	3 - 6	1.1	3 - 0	0.9
N	4 - 7	1.4	4 - 2	1.3
O	17 - 1	5.2	16 - 8	5.1

- VALUES SHOWN ARE FOR CERTIFIED WEIGHTS AND CG LIMITS SPECIFIED FOR GROUND OPERATIONS.
- VALUES APPLY TO STATIC AIRCRAFT ON A FLAT, LEVEL SURFACE.
- IT IS RECOMMENDED THAT ± 3 INCHES BE ALLOWED FOR VERTICAL EXCURSIONS DUE TO LOADING, VARYING STRUT AND TIRE INFLATIONS, PAVEMENT UNEVENNESS, ETC.

2.3 GROUND CLEARANCES MODEL MD-87

155 PASSENGERS, 5-ABREAST SEATING

100 SEATS ON 32-IN. (81.2 CM) PITCH
50 SEATS ON 33-IN. (83.8 CM) PITCH
5 SEATS ON 34-IN. (86.4 CM) PITCH

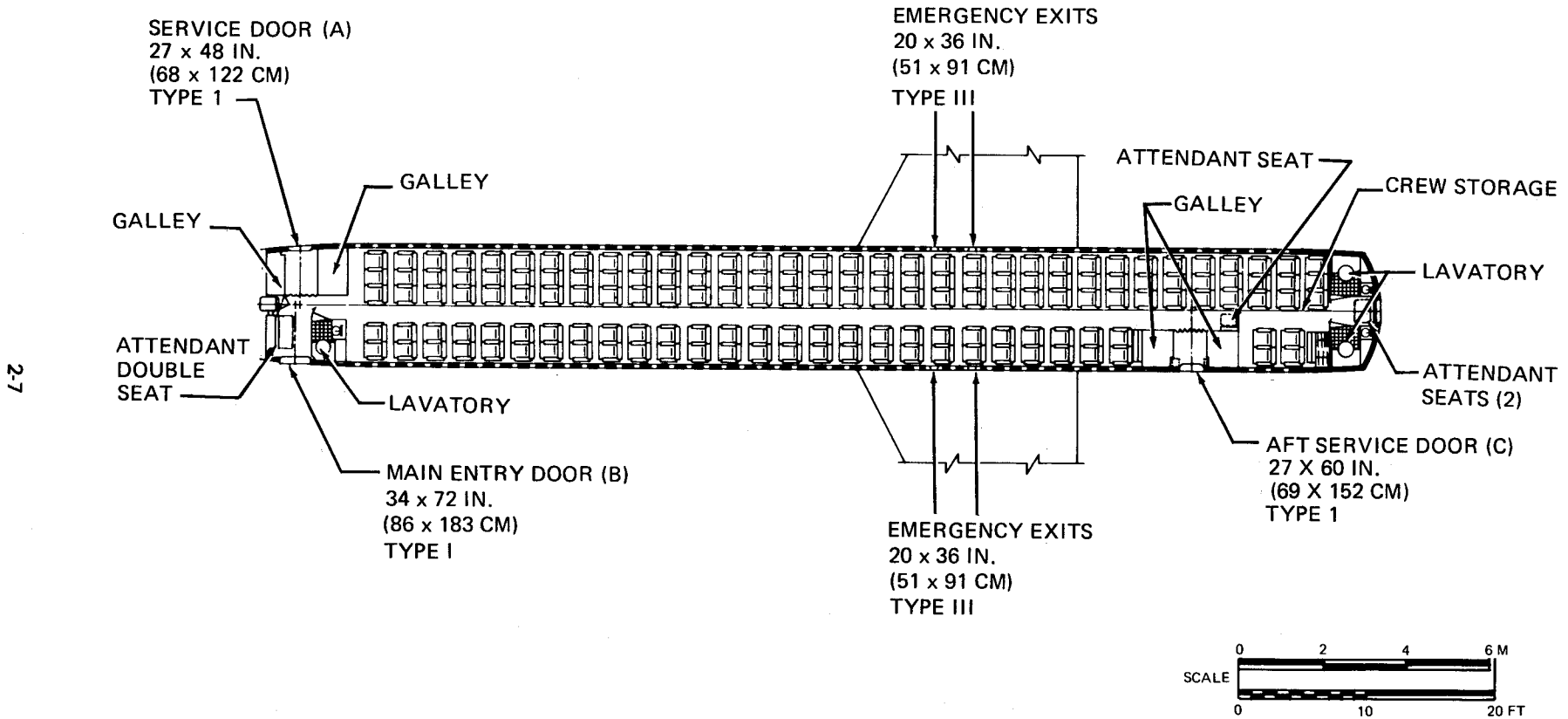

NOTE: MAXIMUM OF 172
PASSENGERS, 5-ABREAST
SEATING AVAILABLE

2.4 INTERIOR ARRANGEMENTS
2.4.1 PASSENGERS
MODEL MD-81, -82, -83, AND -88

130 PASSENGERS, 5-ABREAST SEATING

- 43 SEATS ON 31-IN. (78.7 cm) PITCH
- 34 SEATS ON 32-IN. (81.3 cm) PITCH
- 47 SEATS ON 33-IN. (83.8 cm) PITCH
- 6 SEATS ON 34-IN. (86.4 cm) PITCH

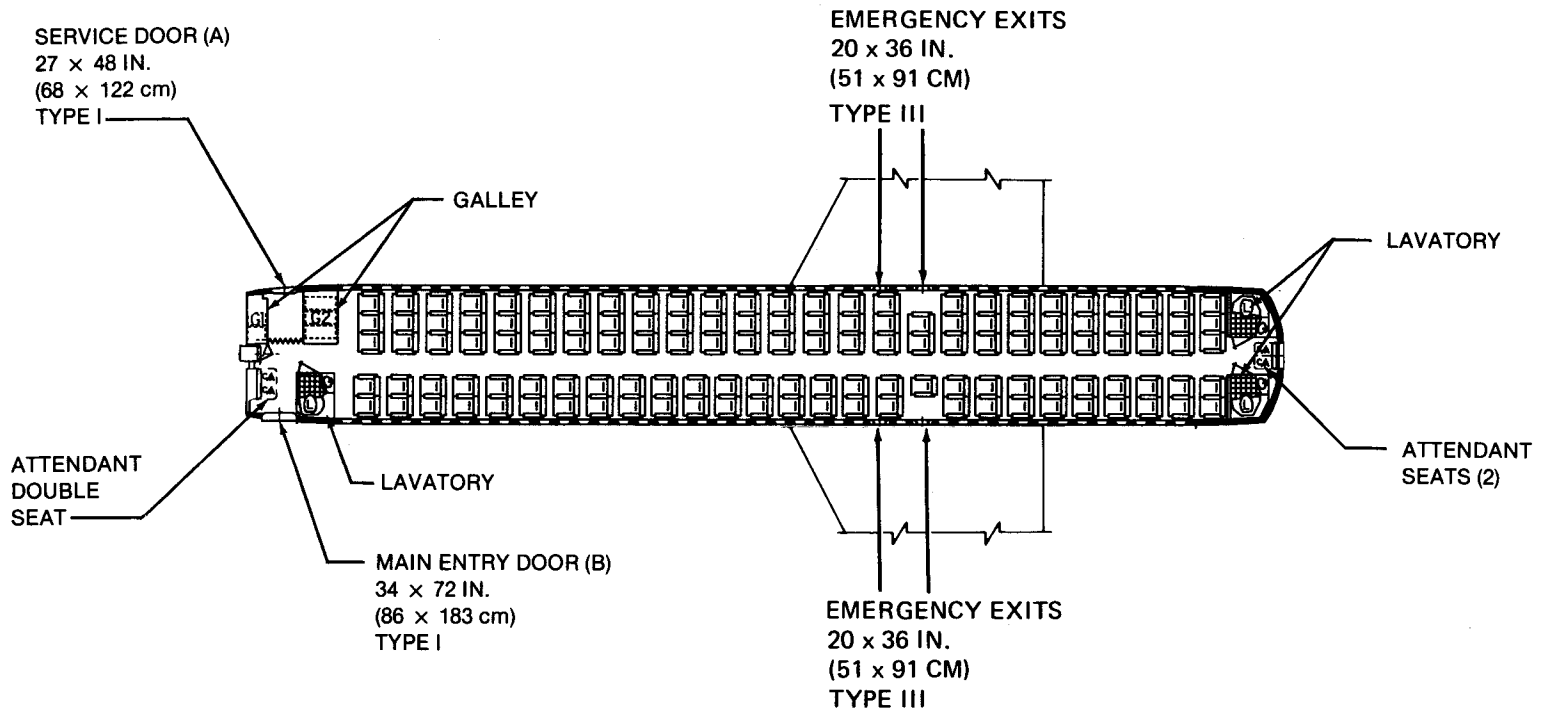

NOTE: MAXIMUM OF 139 PASSENGERS, 5-ABREAST SEATING AVAILABLE

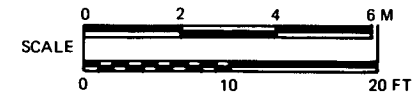

2.4 INTERIOR ARRANGEMENTS
2.4.1 PASSENGERS
MODEL MD-87

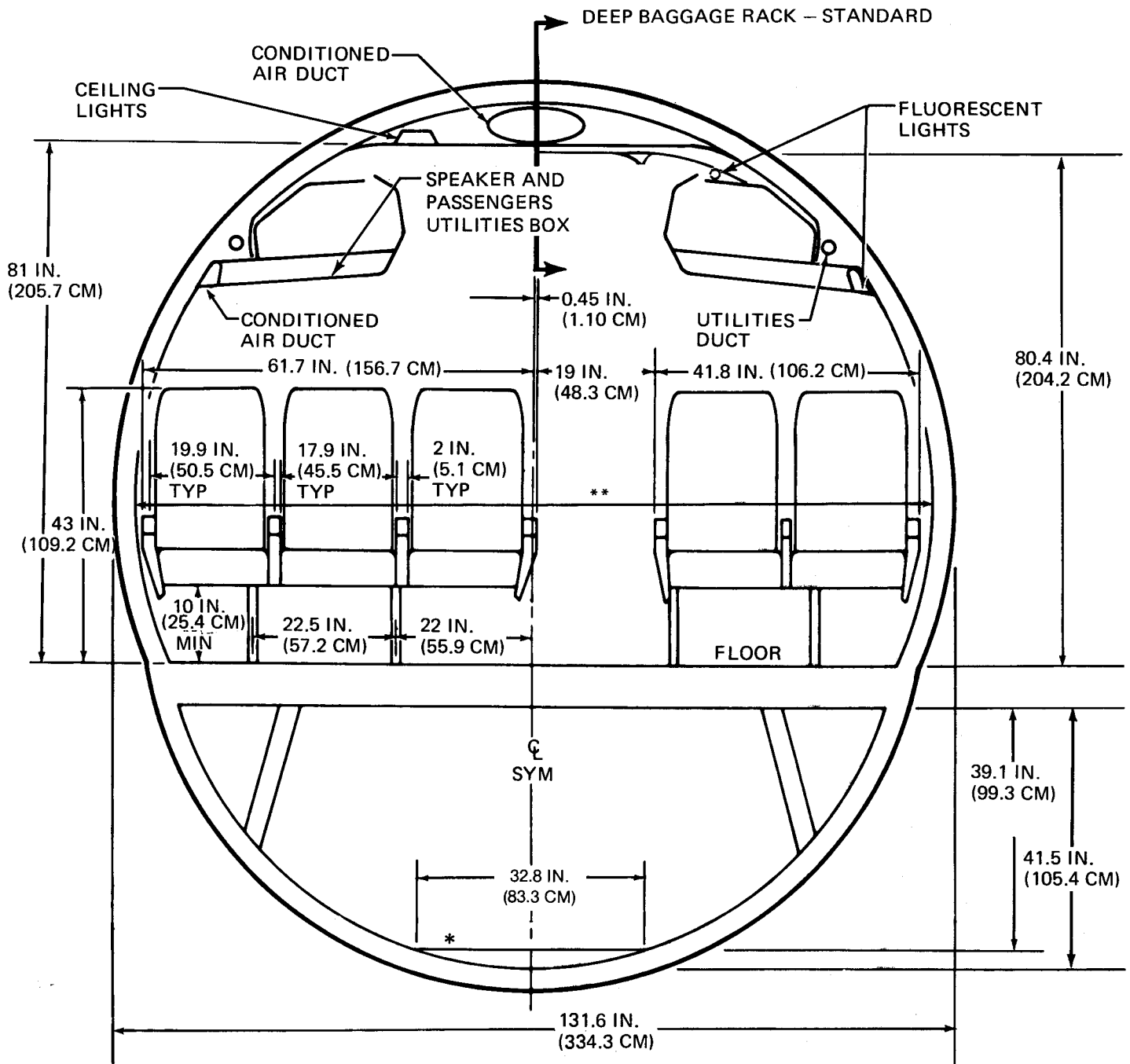

*FLAT FLOOR STANDARD ON MD-80 SERIES IN THE CONSTANT FUSELAGE SECTION (EXCEPT MD-87 AFT CARGO COMPARTMENT)

** TRIM TO TRIM 123.7 IN. (314.2 CM)

2.5 PASSENGER CABIN CROSS SECTION 2.5.1 COACH — MODEL MD-80 SERIES

Rev. 7/89

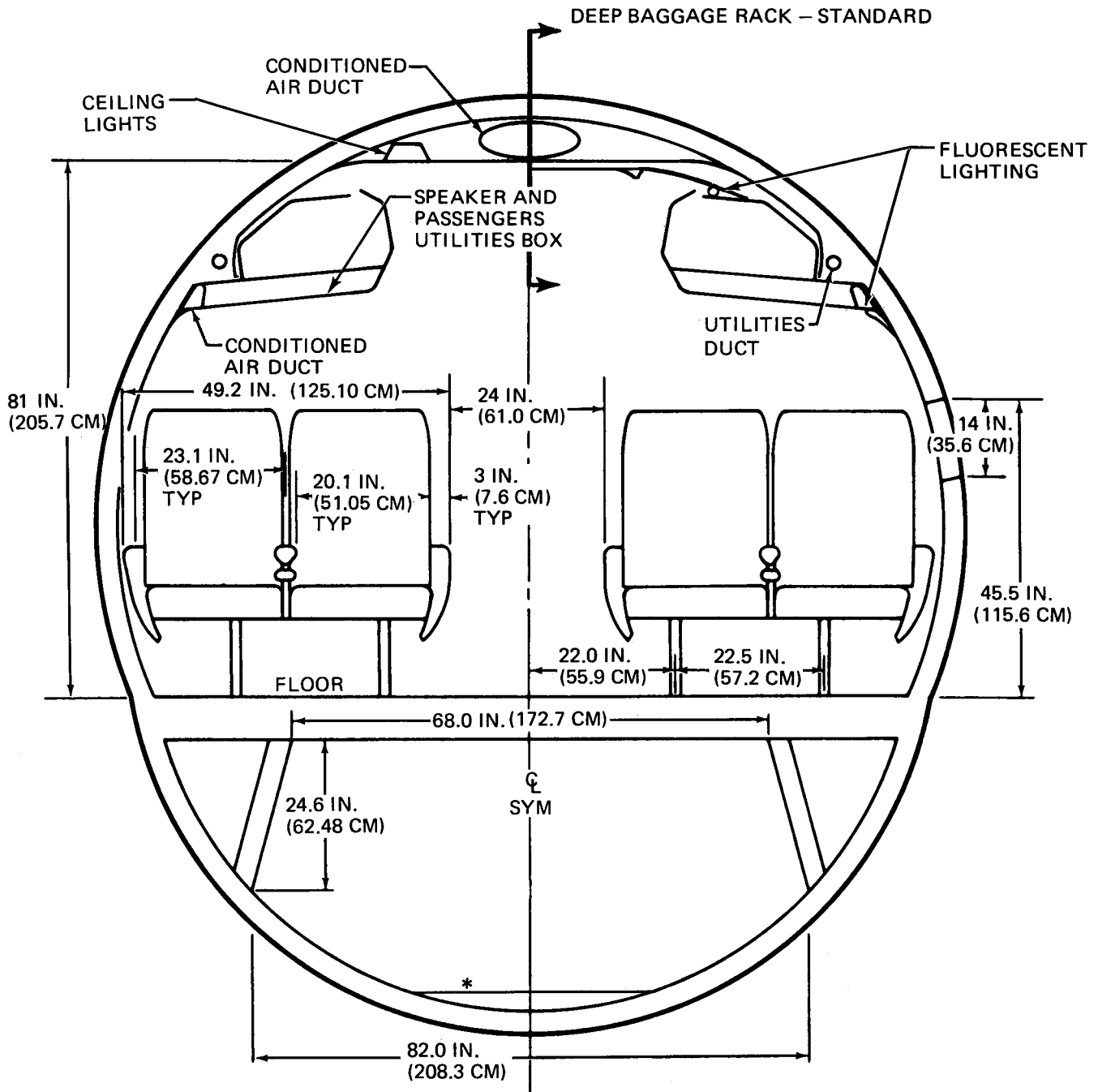

*FLAT FLOOR STANDARD
ON MD-80 SERIES IN THE CONSTANT FUSELAGE SECTION
(EXCEPT MD-87 AFT CARGO COMPARTMENT)

2.5 PASSENGER CABIN CROSS SECTION 2.5.2 FIRST CLASS – MODEL MD-80 SERIES

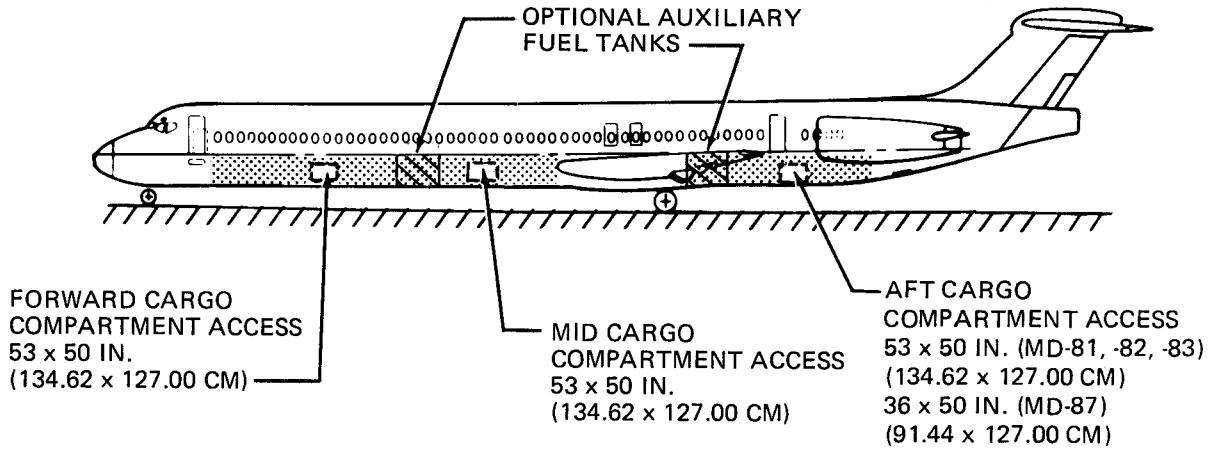

MODEL MD-80	FORWARD CARGO COMPARTMENT	MID CARGO COMPARTMENT	AFT CARGO COMPARTMENT	TOTAL CARGO
-81, -82 PRIOR TO FUSELAGE 1174	464 FT ³ (13.1 M ³)	346 FT ³ (9.8 M ³)	443 FT ³ (12.5 M ³)	1253 FT ³ (35.5 M ³)
-81, -82, -88 FUSELAGE 1174 +	434 FT ³ (12.3 M ³)	376 FT ³ (10.6 M ³)	443 FT ³ (12.5 M ³)	1253 FT ³ (35.5 M ³)
-83*	434 FT ³ (12.3 M ³)	253 FT ³ (7.2 M ³)	326 FT ³ (9.2 M ³)	1013 FT ³ (28.7 M ³)
-87	252 FT ³ (7.1 M ³)	376 FT ³ (10.7 M ³)	310 FT ³ (8.8 M ³)	938 FT ³ (26.6 M ³)
-87*	252 FT ³ (7.1 M ³)	253 FT ³ (7.2 M ³)	190 FT ³ (5.4 M ³)	695 FT ³ (19.7 M ³)

*WITH FUSELAGE AUXILIARY FUEL TANKS

2.6 LOWER COMPARTMENTS (BULK CARGO) MODEL MD-80 SERIES

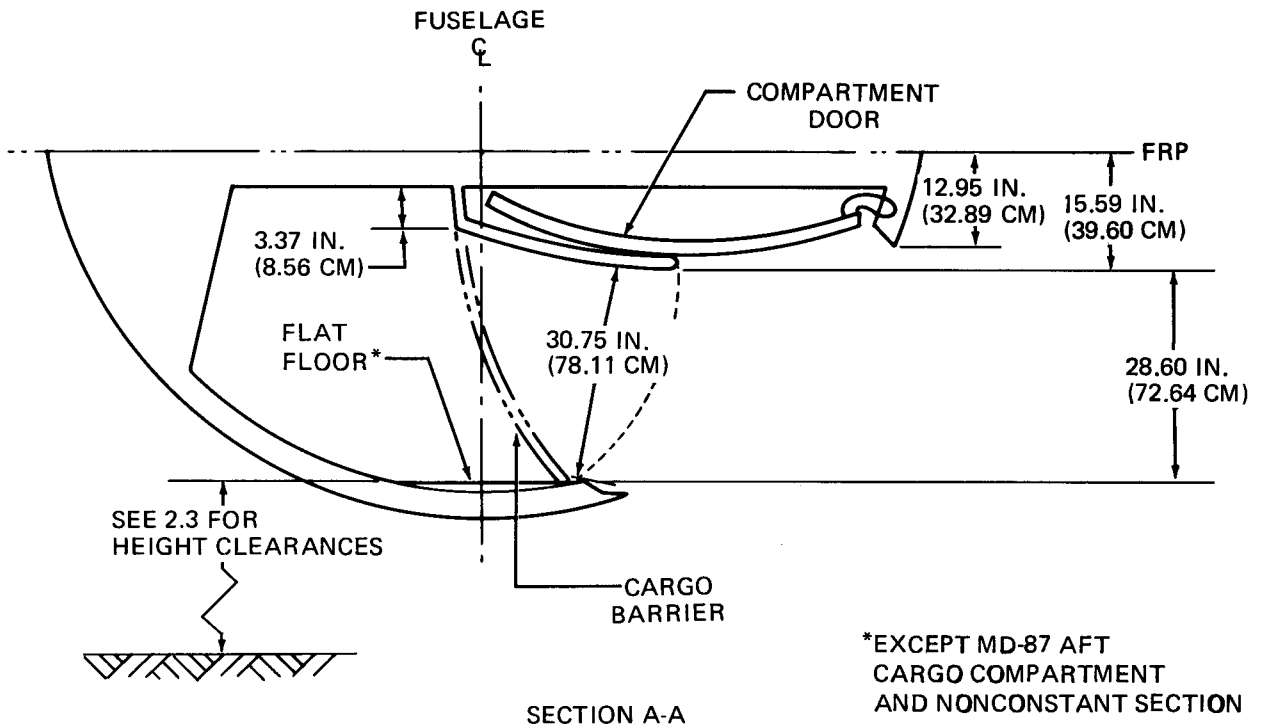
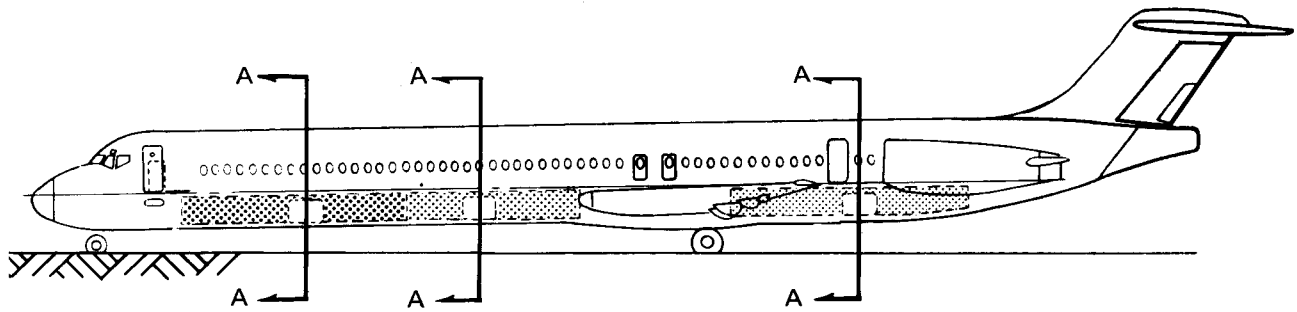

2.7 DOOR CLEARANCES
2.7.1 LOWER FORWARD, MID, AND AFT CARGO
DOOR CLEARANCES
MODEL MD-80 SERIES

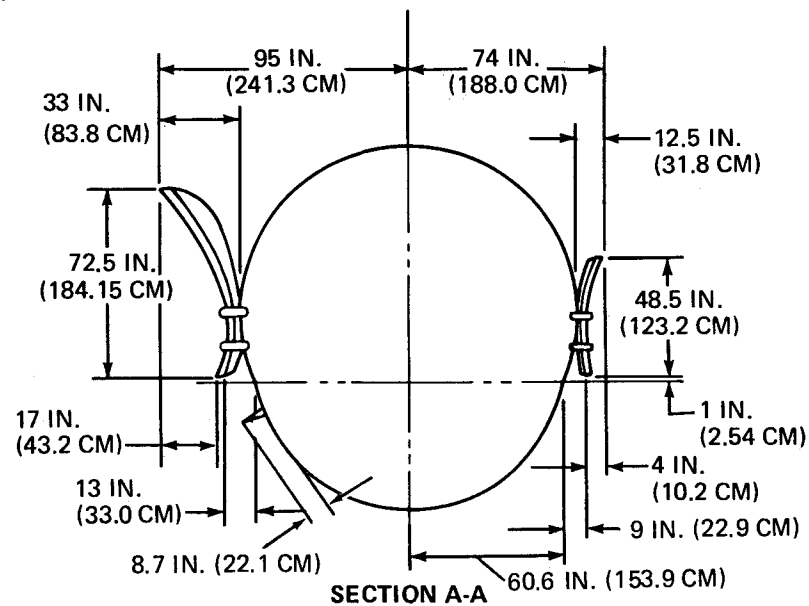
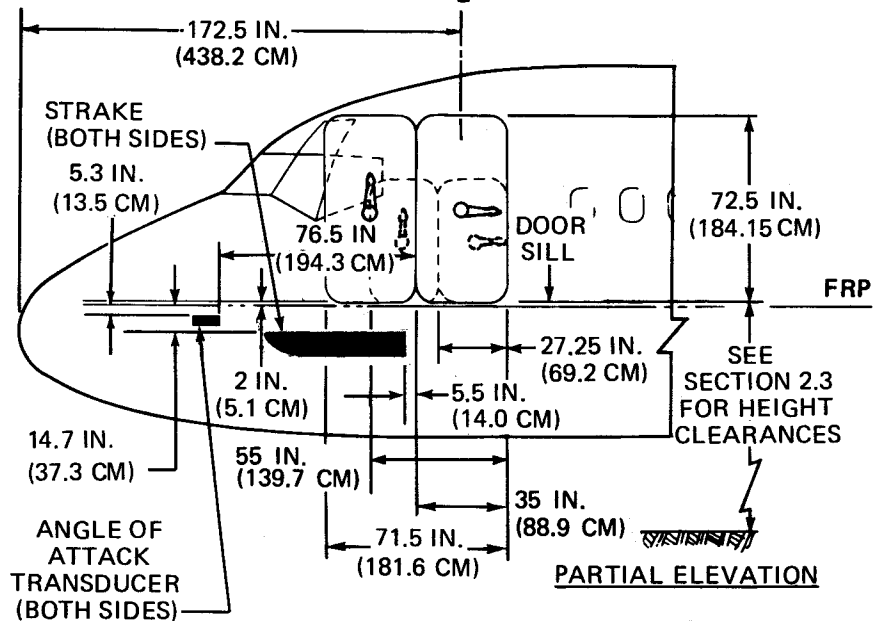
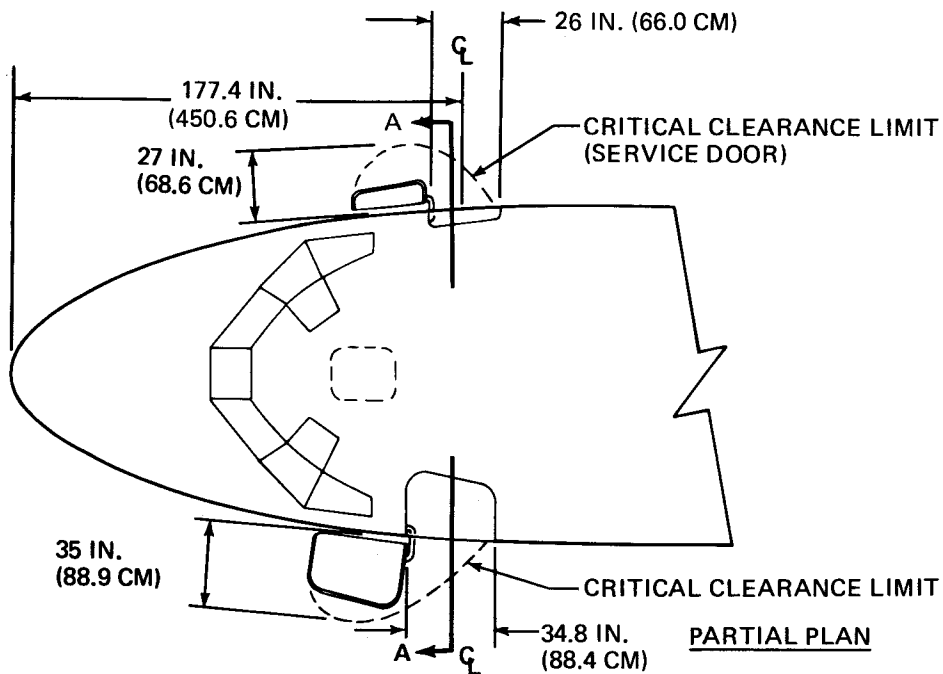

2.7 DOOR CLEARANCES
2.7.2 PASSENGER ENTRANCE AND SERVICE DOOR CLEARANCES
MODEL MD-80 SERIES

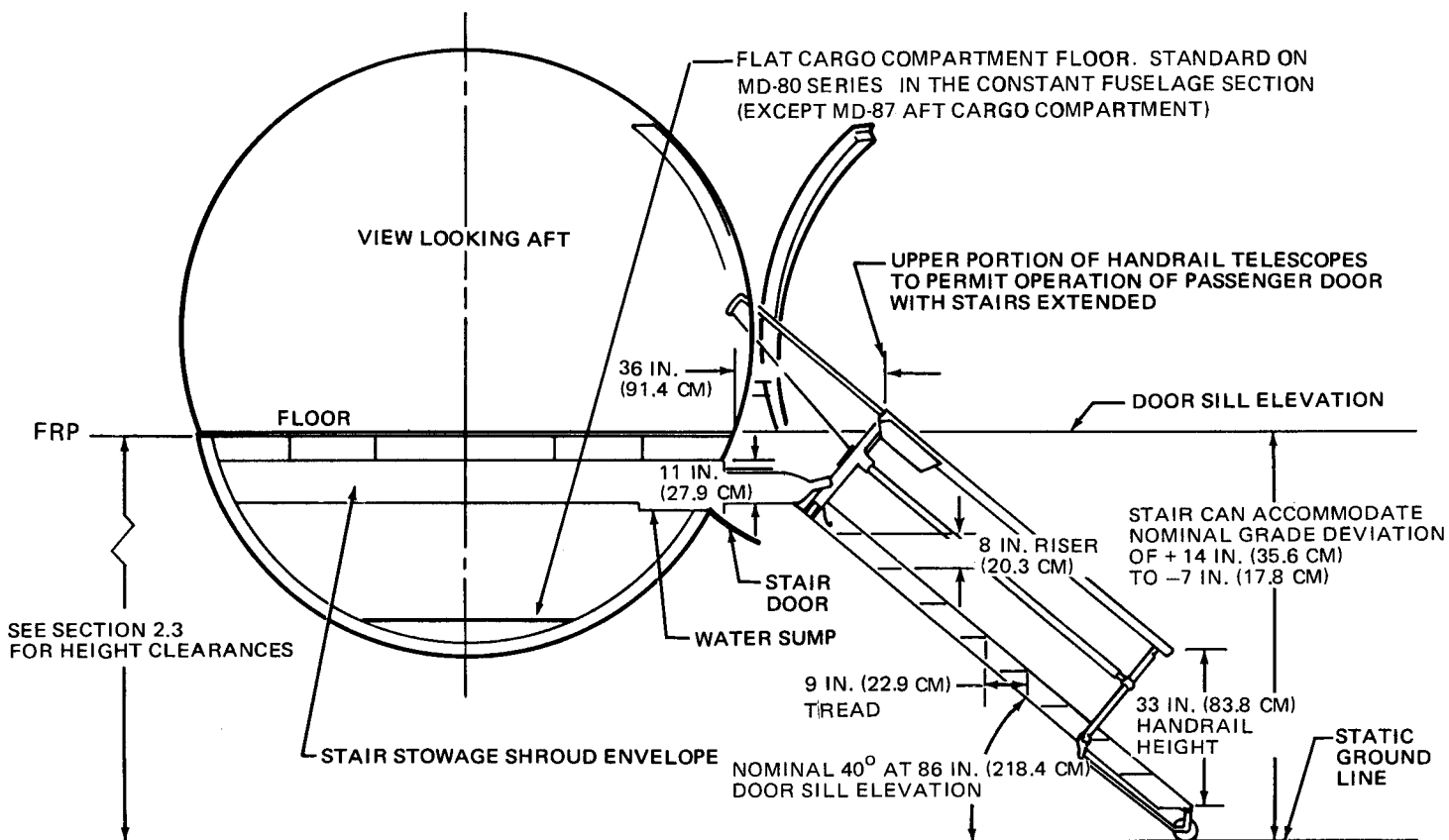

2.7 DOOR CLEARANCES
2.7.3 MAIN ENTRANCE STAIRWAY CLEARANCES
MODEL MD-80 SERIES

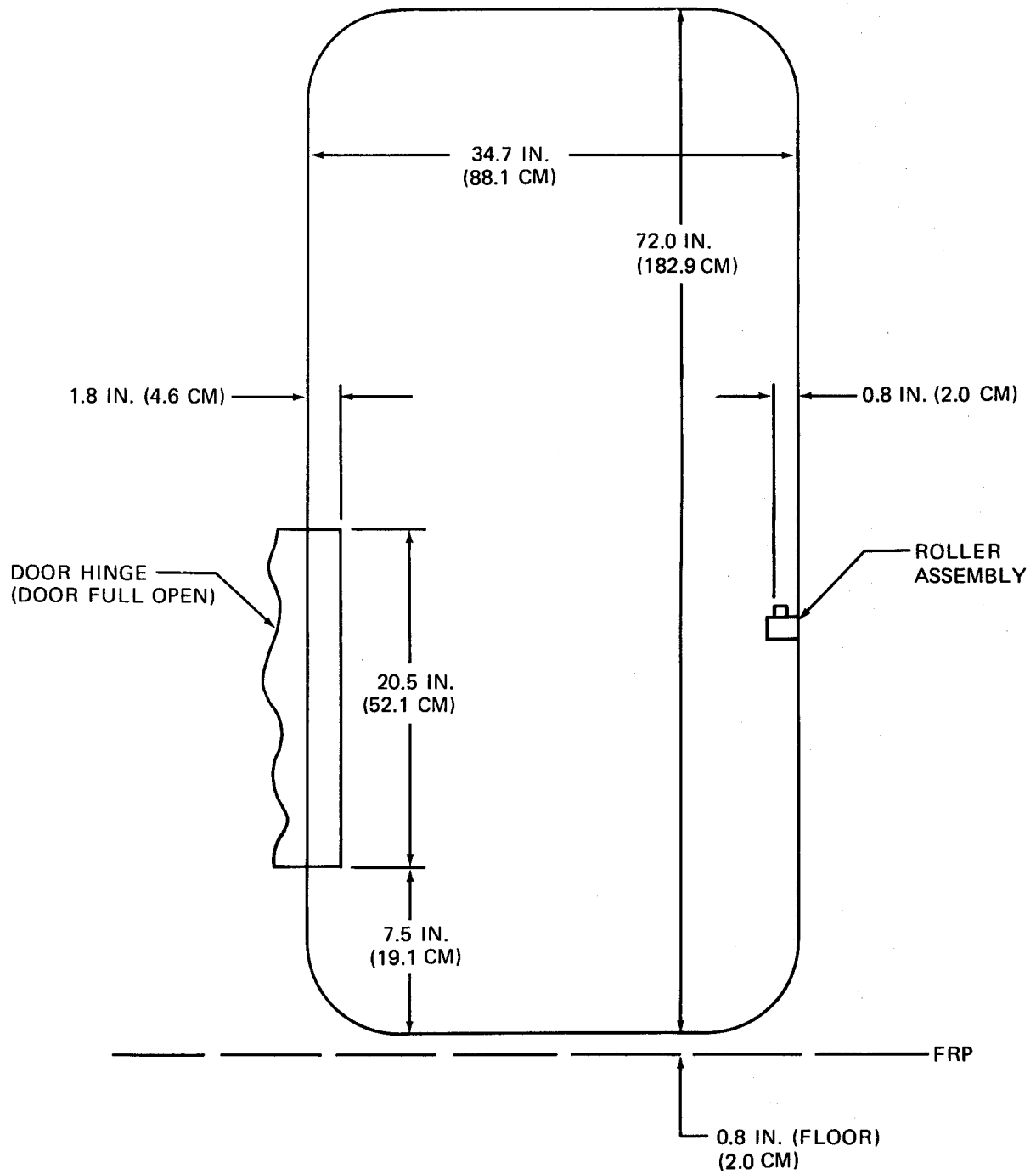

2.7 DOOR CLEARANCES
2.7.4 FORWARD PASSENGER DOOR OPENING CLEARANCES
MODEL MD-80 SERIES

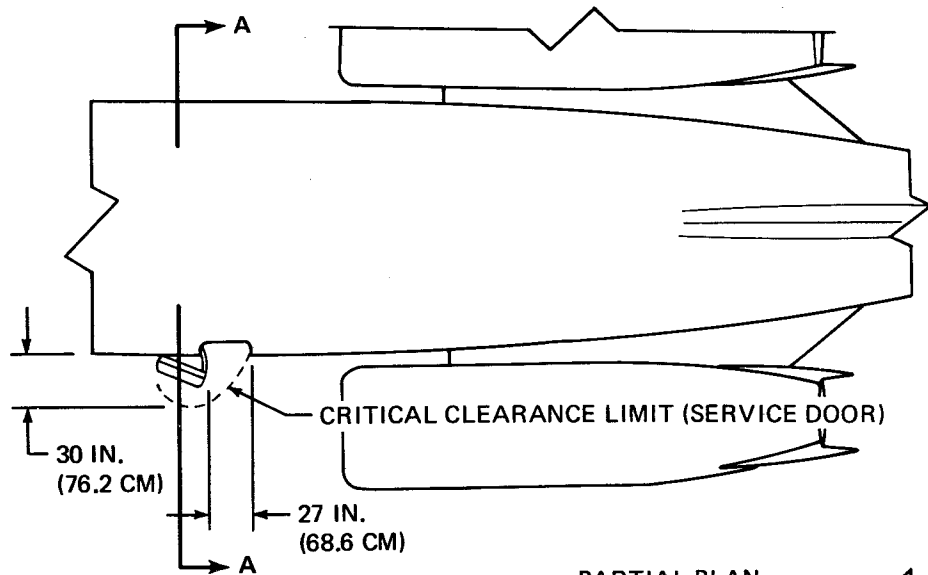

PARTIAL PLAN

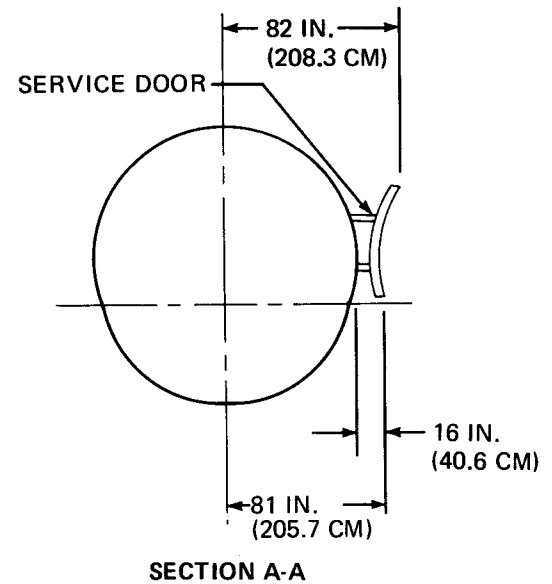
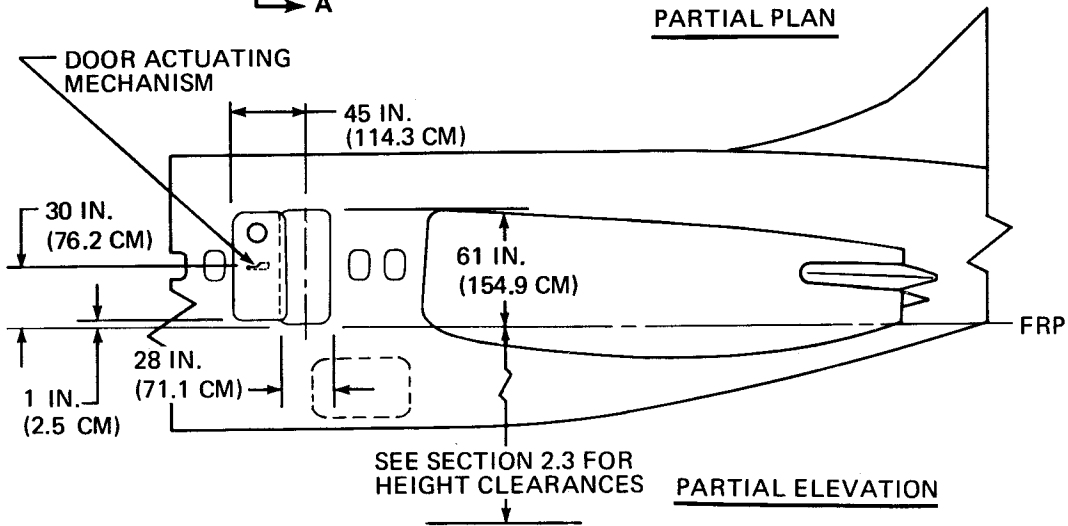

2.7 DOOR CLEARANCES
2.7.5 AFT SERVICE DOOR CLEARANCES
MODEL MD-81, -82, -83, AND -88

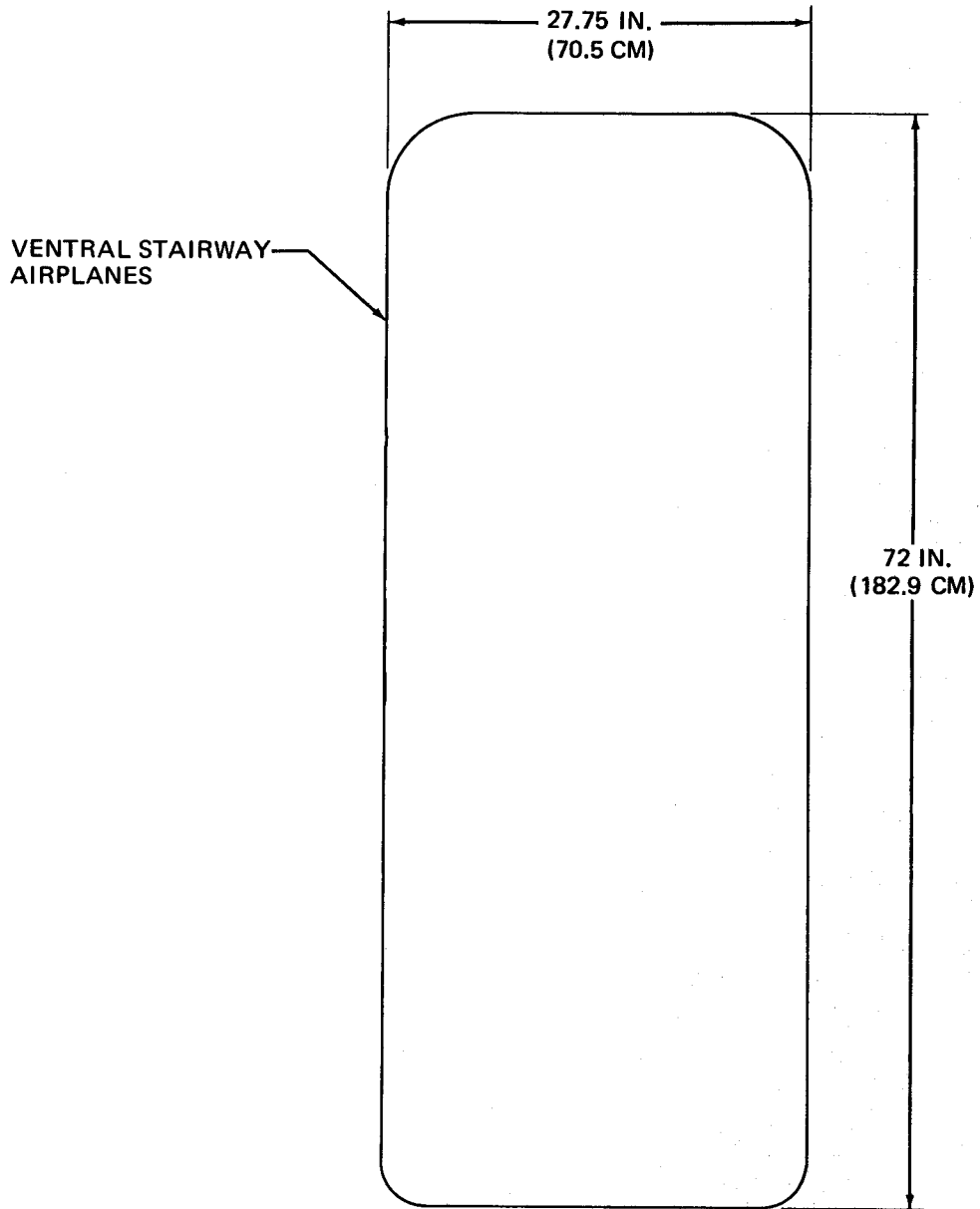

2.7 DOOR CLEARANCES
2.7.6 AFT PRESSURE BULKHEAD DOOR OPENING CLEARANCES
MODEL MD-80 SERIES

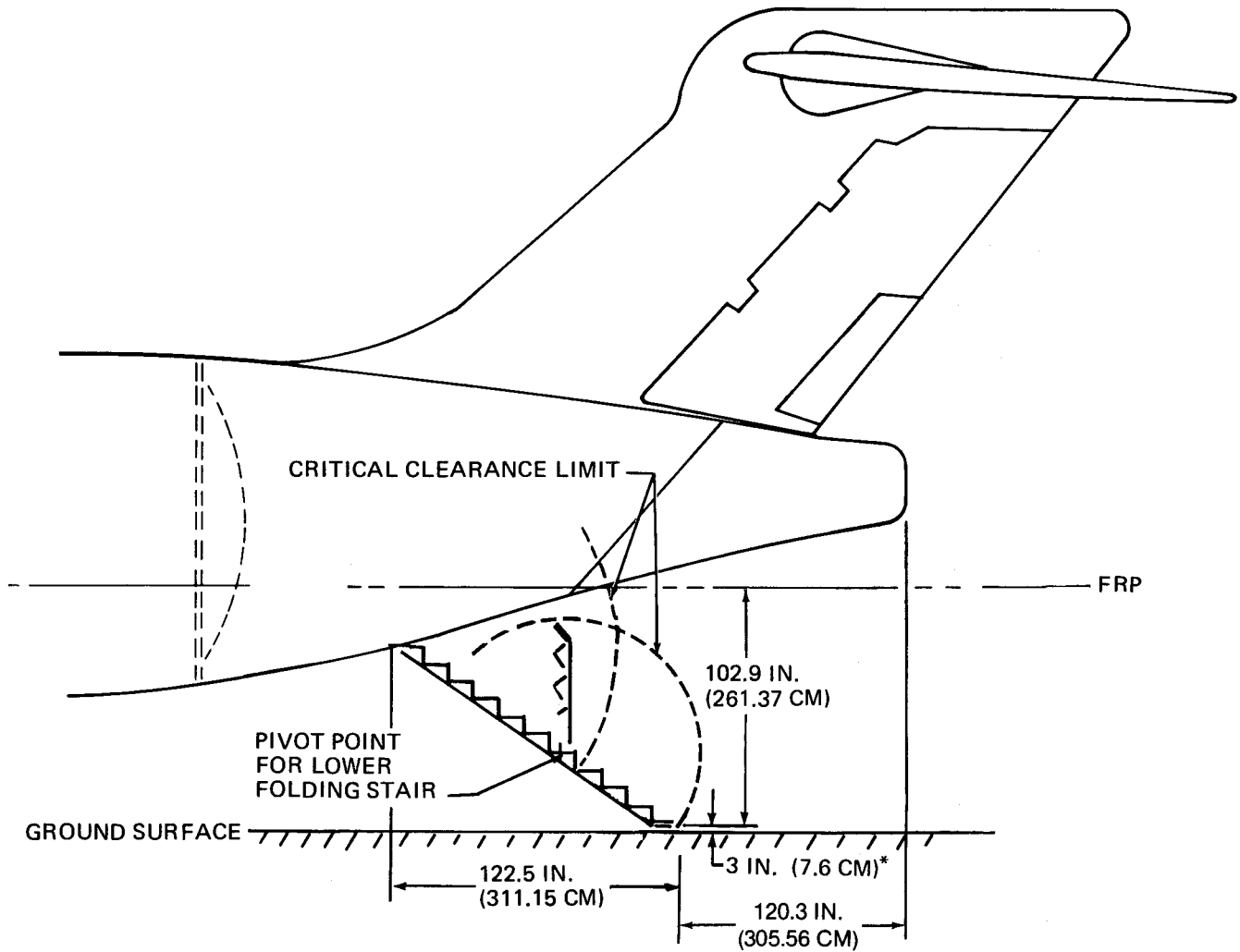

*VARIES WITH WEIGHT, CG LOCATION, AND LANDING GEAR STRUT COMPRESSION

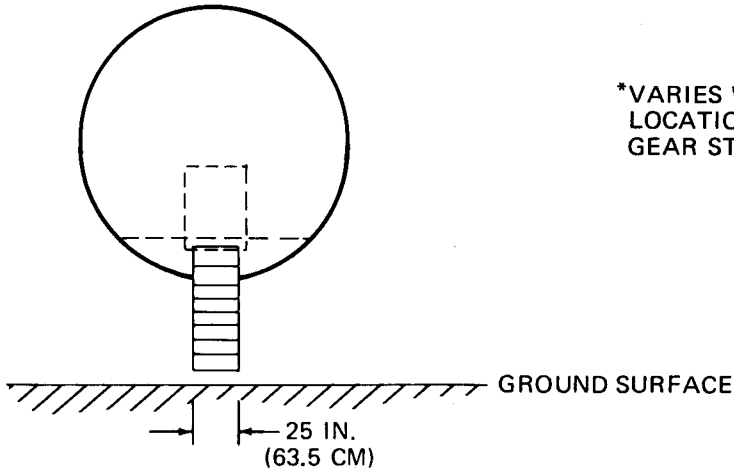

2.7 DOOR CLEARANCES
2.7.7 VENTRAL STAIR CLEARANCES
MODEL MD-80 SERIES