

# 747-8F - 16% more volume than the 747-400F

**747-8 Freighter**  
134 tonnes

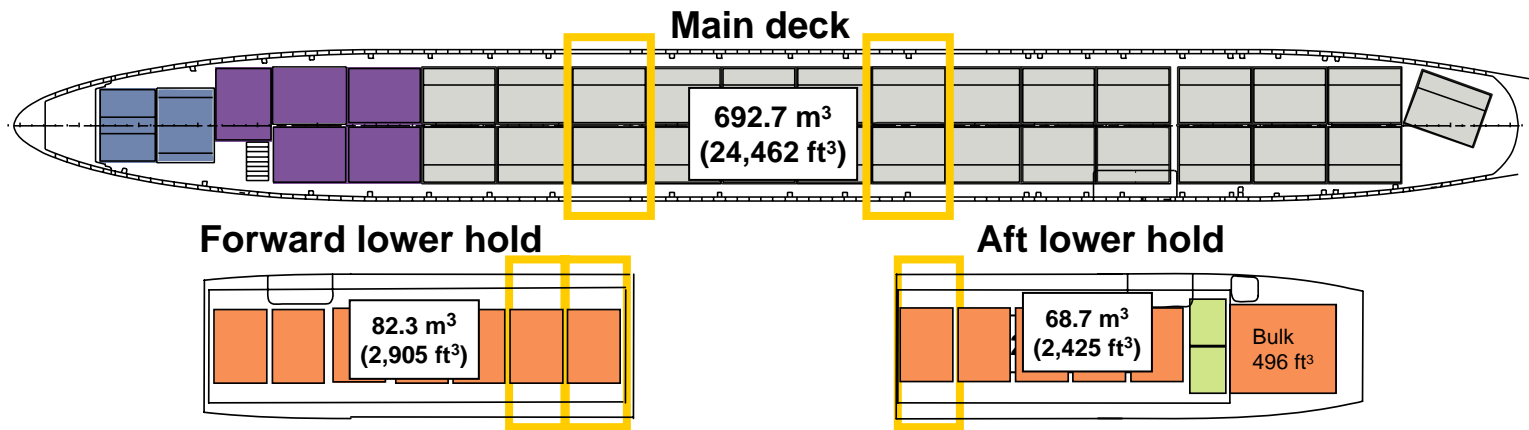
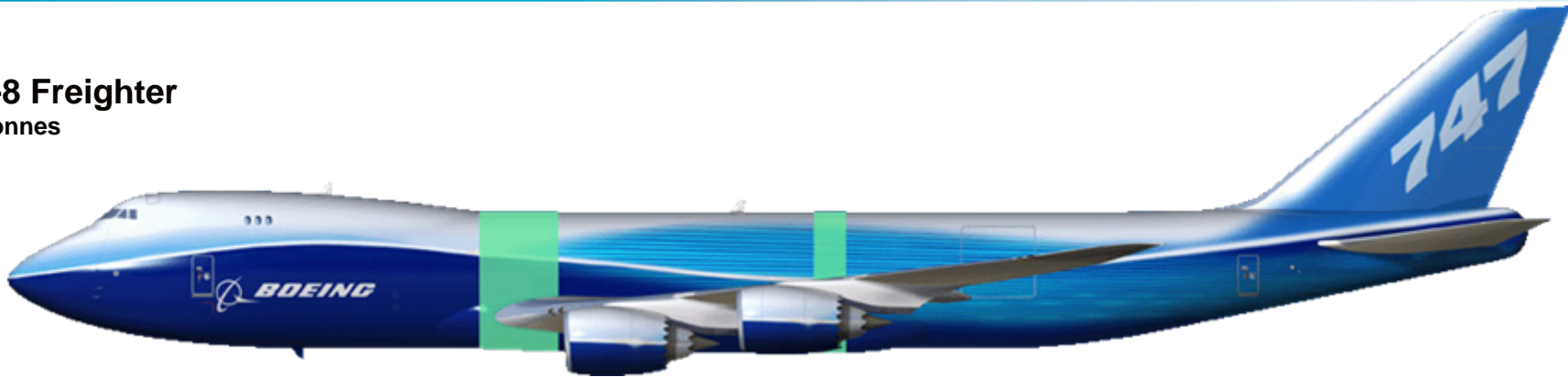

**Additional pallets and containers**

- (27) 96-in x 125-in x 10-ft contoured pallets [21.1 m<sup>3</sup> (750 ft<sup>3</sup>)]
- (5) 96-in x 125-in x 8-ft contoured pallets [17.4 m<sup>3</sup> (613 ft<sup>3</sup>)]
- (2) 96-in x 125-in x 8-ft contoured pallets [15.3 m<sup>3</sup> + 17.2 m<sup>3</sup> (540 ft<sup>3</sup>+ 607 ft<sup>3</sup>)]
- (12) 96-in x 125-in contoured pallets [11.8 m<sup>3</sup> (415 ft<sup>3</sup>)]
- (2) LD-1 containers [5.0 m<sup>3</sup> (175 ft<sup>3</sup>)]

\* Includes bulk cargo

**Total volume\* = 858 m<sup>3</sup> (30,288 ft<sup>3</sup>)**

# 747 Freighter lower cargo compartment door

747-8

Rear view

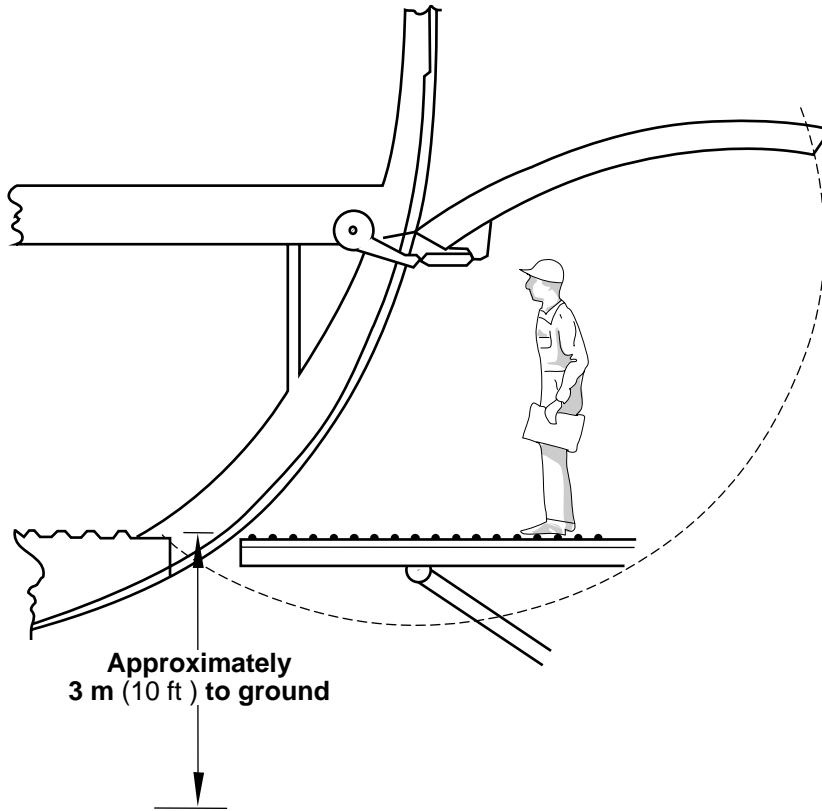

Right-hand side view

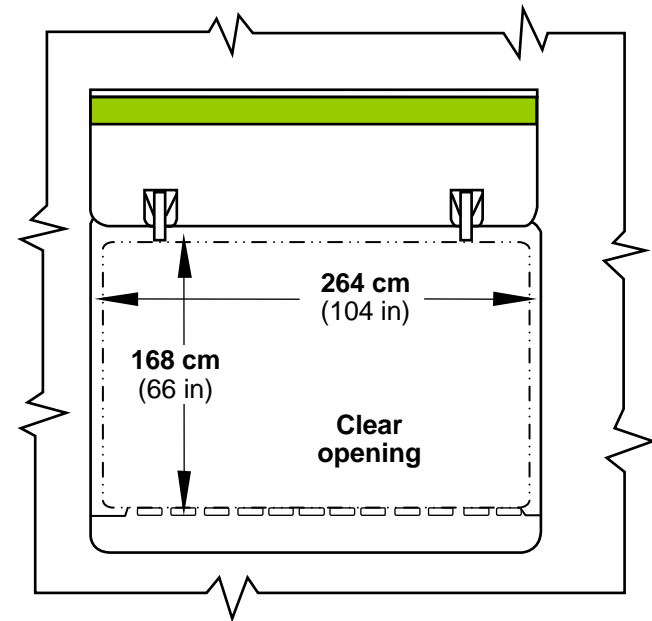

# 747 Freighter lower hold capability

# 747-8

## Containers and pallets

### Basic

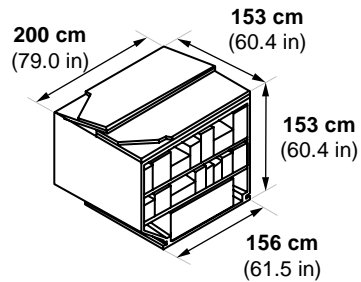

**1,588-kg (3,500-lb) MGW**  
**4.5 m<sup>3</sup> (160 ft<sup>3</sup>)**  
**(LD-3)**

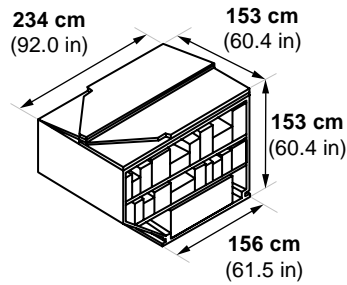

**1,588-kg (3,500-lb) MGW**  
**4.9 m<sup>3</sup> (175 ft<sup>3</sup>)**  
**(LD-1)**

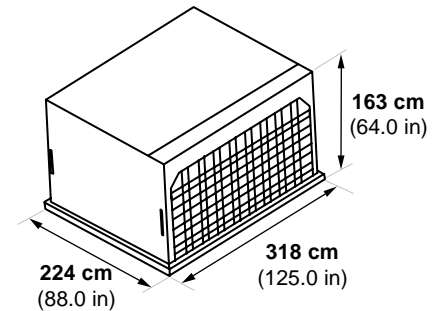

**4,627-kg (10,200-lb) MGW\***  
**10.8 m<sup>3</sup> (381 ft<sup>3</sup>)**  
**(LD-9)**

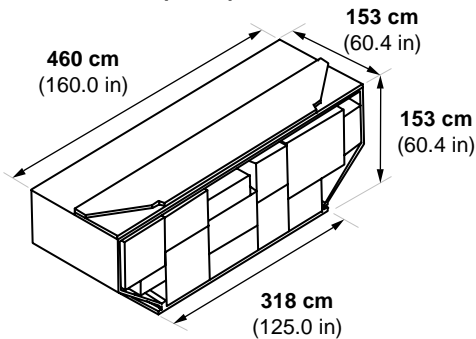

**3,175-kg (7,000-lb) MGW\***  
**8.9 m<sup>3</sup> (316 ft<sup>3</sup>)**  
**(LD-6)**

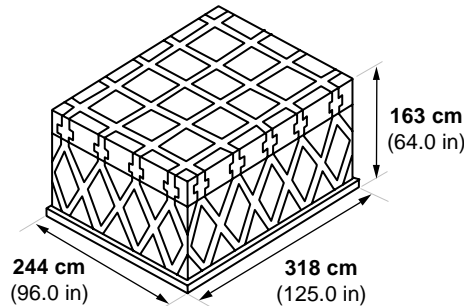

**5,035-kg (11,100-lb) MGW\***  
**11.8 m<sup>3</sup> (415 ft<sup>3</sup>)**

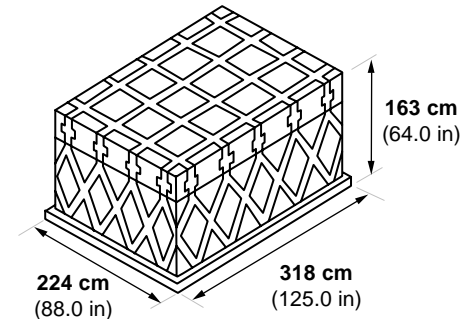

**4,627-kg (10,200-lb) MGW\***  
**10.7 m<sup>3</sup> (379 ft<sup>3</sup>)**

\* Maximum gross weights shown are based on lower hold running load capability, 21 kg/cm (116 lb/in), subject to overall airframe structural limits.