

747-400 Freighter

Main deck cargo arrangements

StartupBoeing

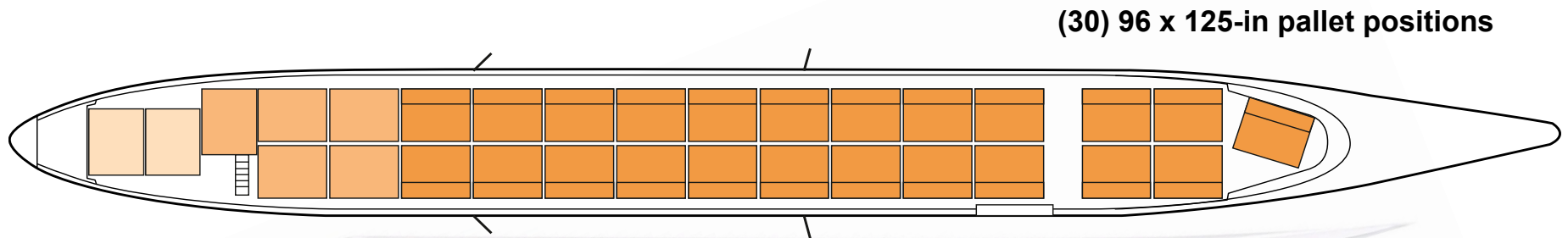

(2) 96 x 125-in x 8-ft contoured pallets at 15.3 m³ and 17.2 m³ (540 ft³ and 607 ft³)

(5) 96 x 125-in x 8-ft pallets at 17.4 m³ (613 ft³)

(23) 96 x 125-in x 10-ft contoured pallets at 21.2 m³ (750 ft³)

Total 607.7 m³ 21,462 ft³

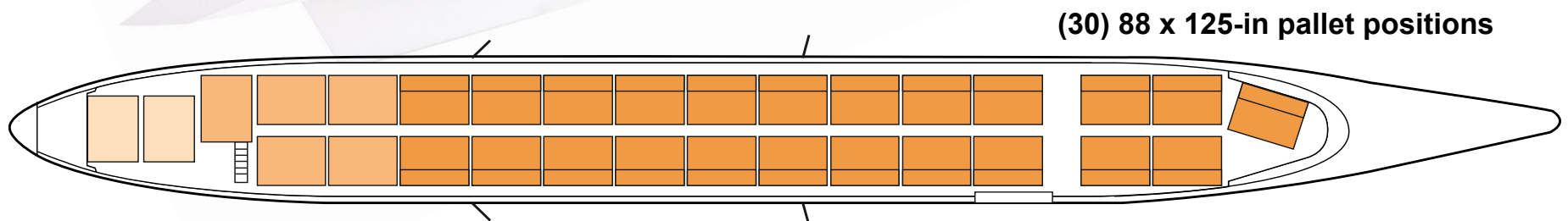

(2) 88 x 125-in x 8-ft contoured pallets at 13.9 m³ and 15.7 m³ (493 ft³ and 554 ft³)

(5) 88 x 125-in x 8-ft pallets at 15.9 m³ (560 ft³)

(23) 88 x 125-in x 10-ft contoured pallets at 19.3 m³ (680 ft³)

Total 553 m³ 19,487 ft³

747-400/-400ER Freighter

Nose door loading

StartupBoeing

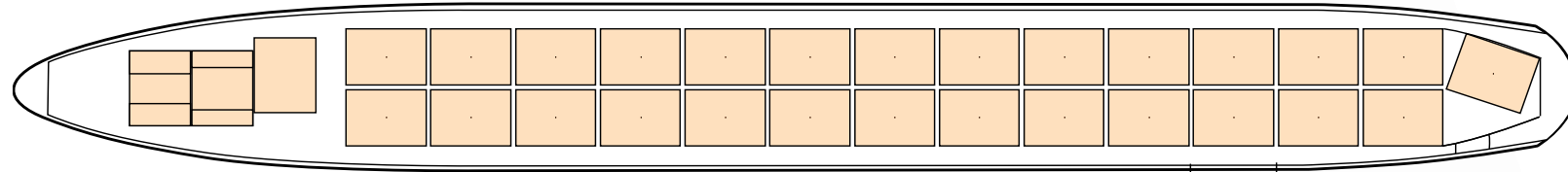

(29) 10-ft (3-m) containers

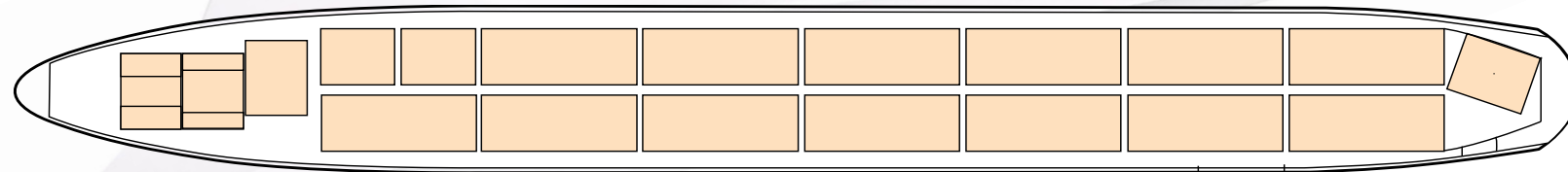

**(13) 20-ft (6-m) intermodal containers
(5) 10-ft (3-m) containers**

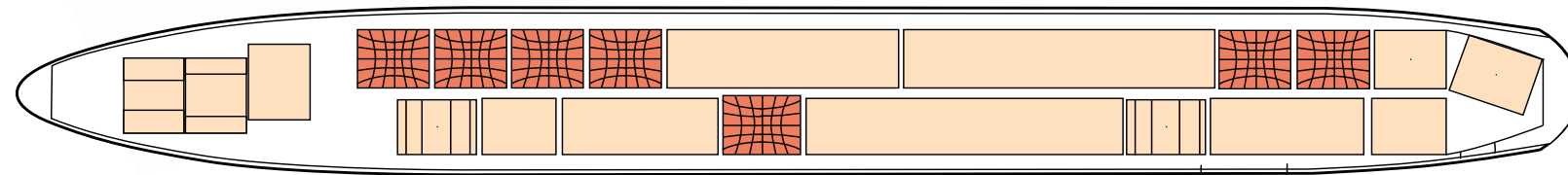

Random intermix, 10-, 20-, 30-, and 40-ft (3-, 6-, 9-, and 12-m) loads

747-400/-400ER Freighter

StartupBoeing

Side cargo door loading 6-meter (20-foot) container

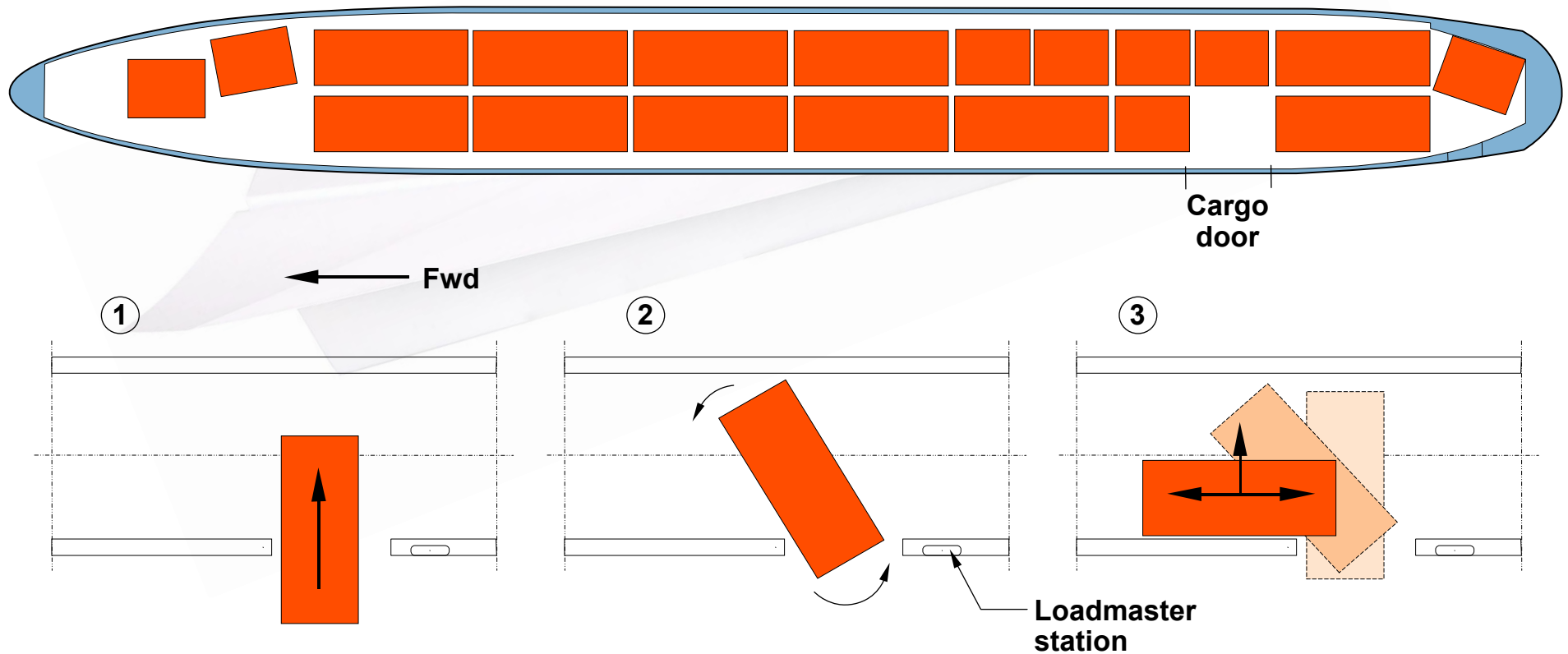

747-400/-400ER Freighter

Upper deck arrangement

StartupBoeing

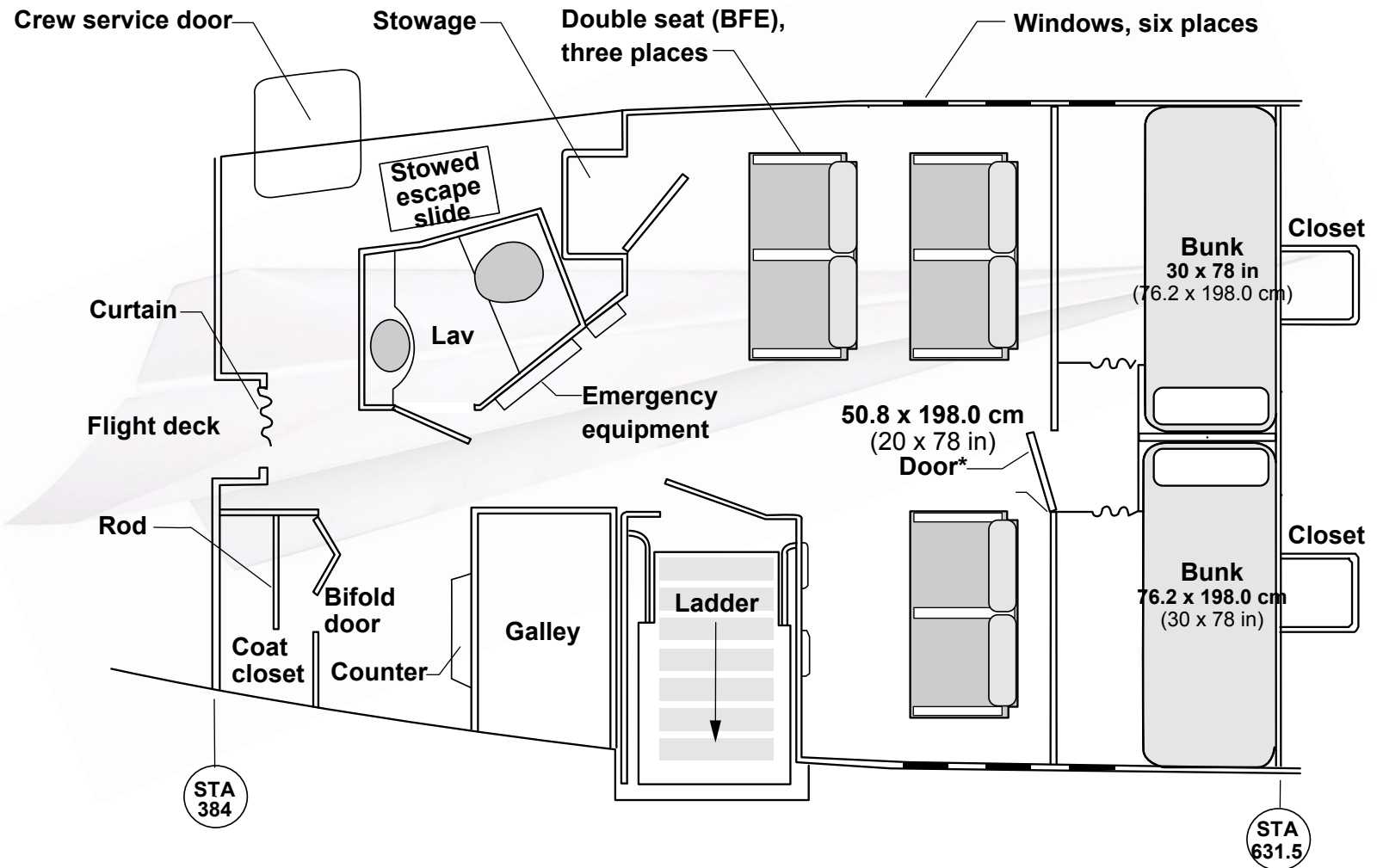

747-400/-400ER Freighter

Upper deck ladder operation

StartupBoeing

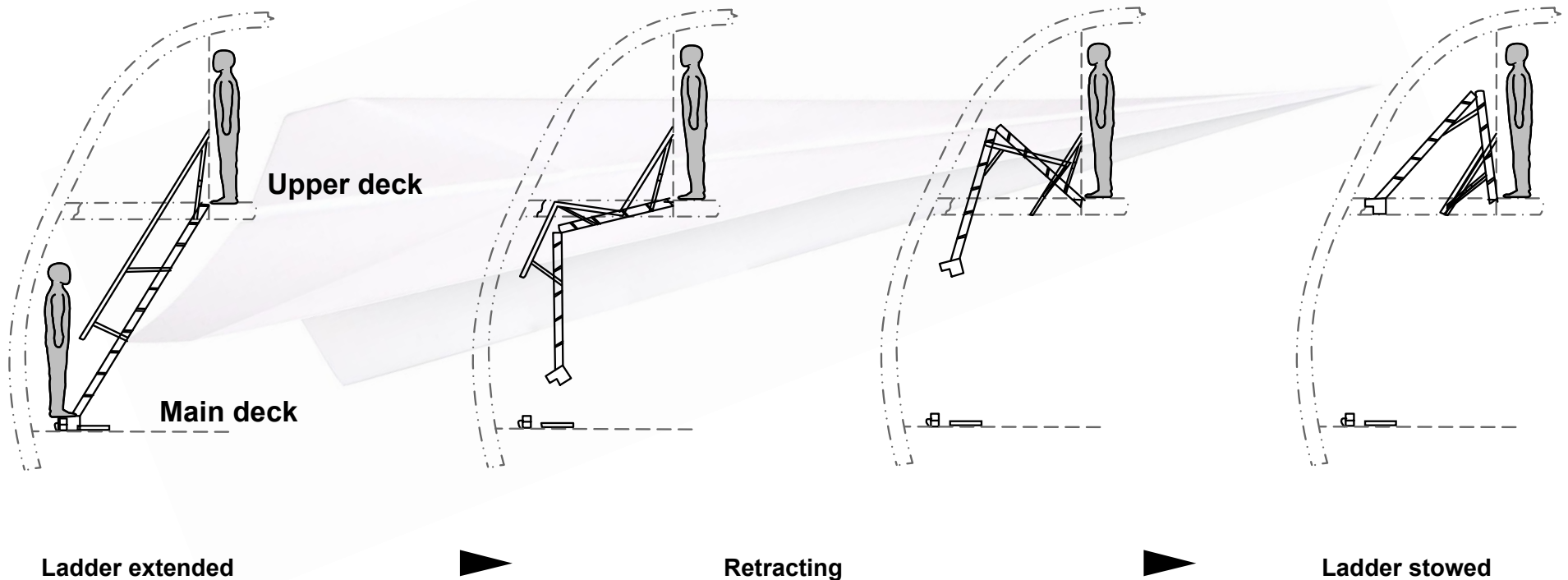

747-400/-400ER Freighter

StartupBoeing

Additional 10-foot-high cargo capacity

6.8 m³ (240 ft³) more cargo volume than the 747-200

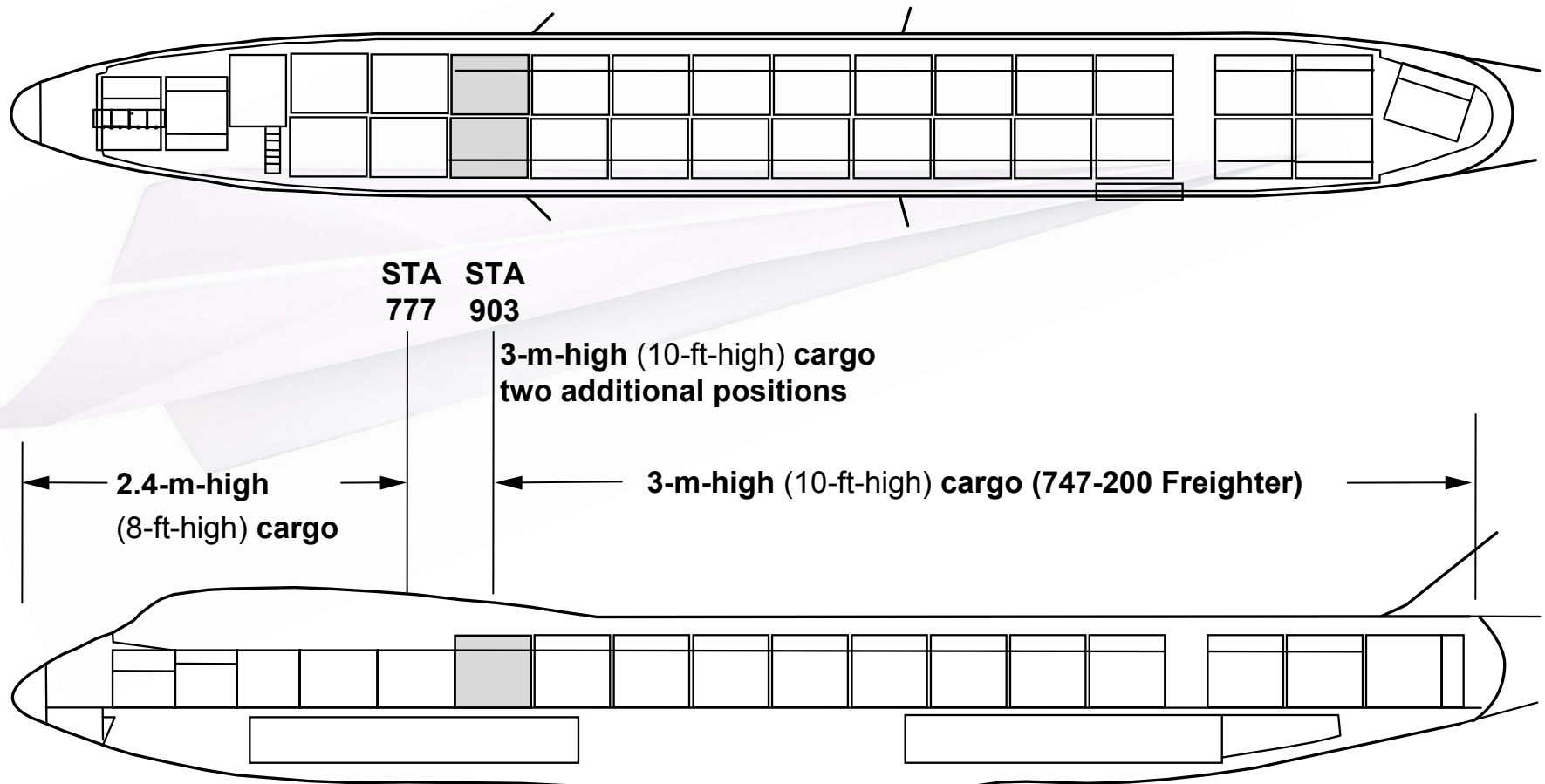

747-400/-400ER Freighter

Additional main deck pallet

StartupBoeing

747-200 Freighter
Existing positions P1, P2

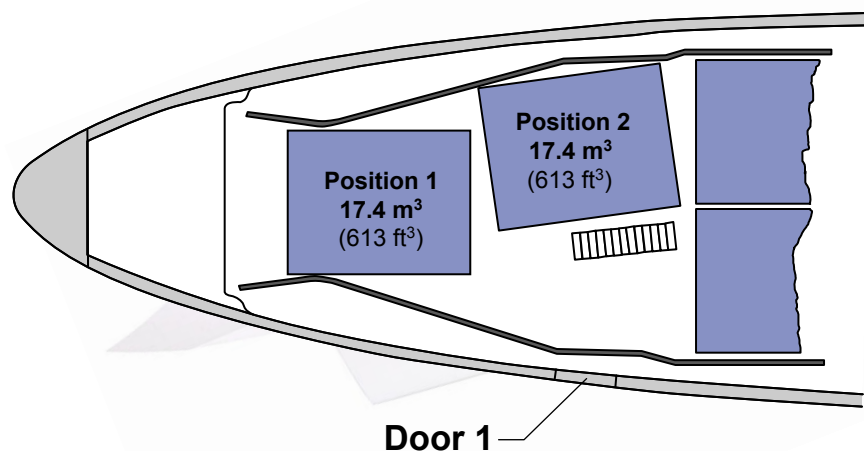

747-400 Freighters

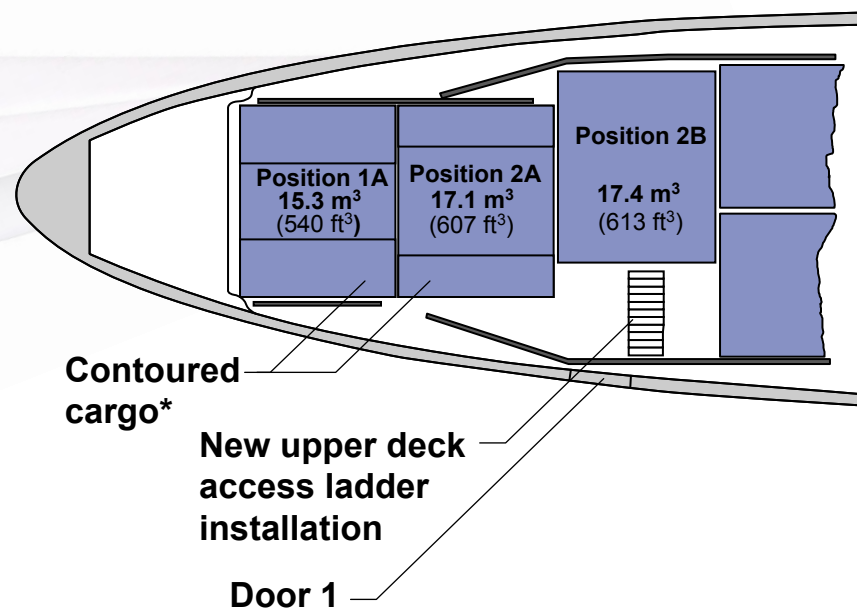

More than 15.1-m³ (534-ft³) volume increase (one additional pallet)

*Position 2A can be a full container (uncontoured) when loaded through the side cargo door.

747-400/-400ER Freighter

Additional cargo volume capability

StartupBoeing

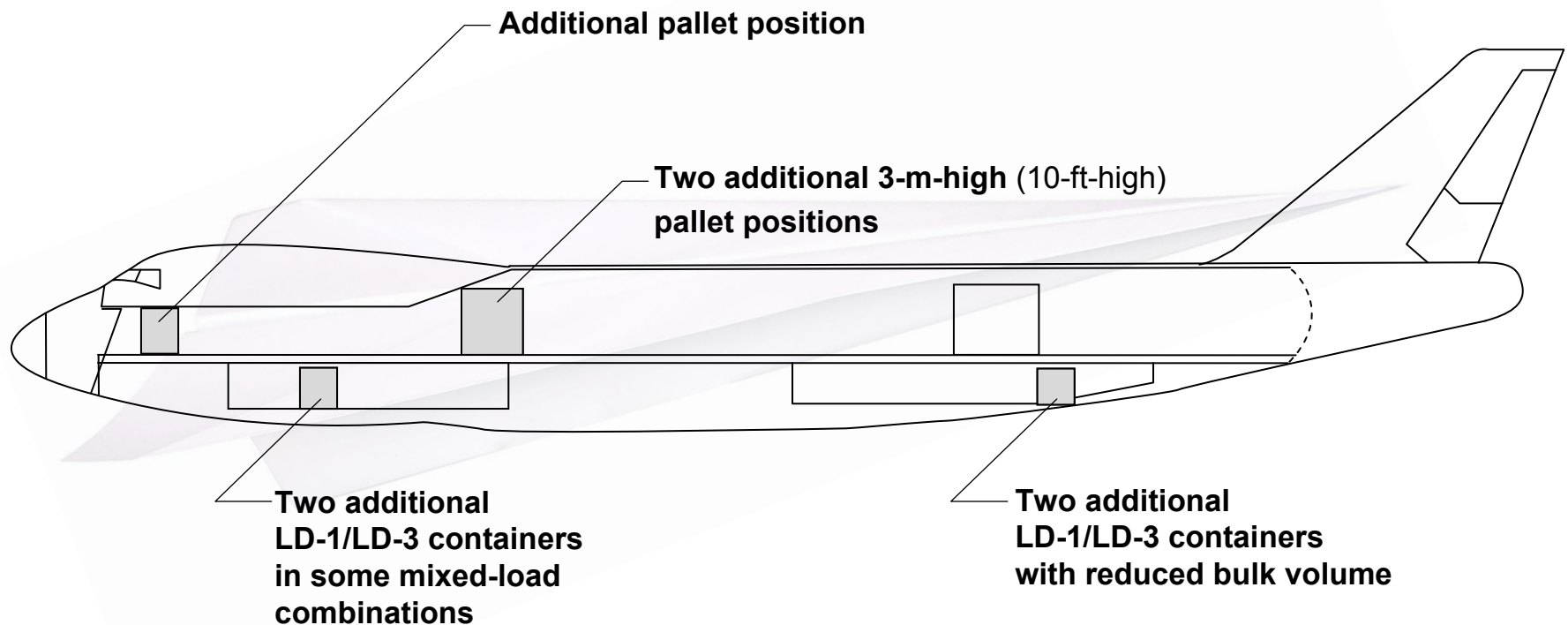

The 747-400 Freighters have 21.9 m³ (774 ft³) more main deck volume and up to 11.9 m³ (420 ft³) more lower hold volume than the 747-200 Freighter

747-400/-400ER Freighter

Structural loading limits

Running load capability, kg/cm (lb/in)

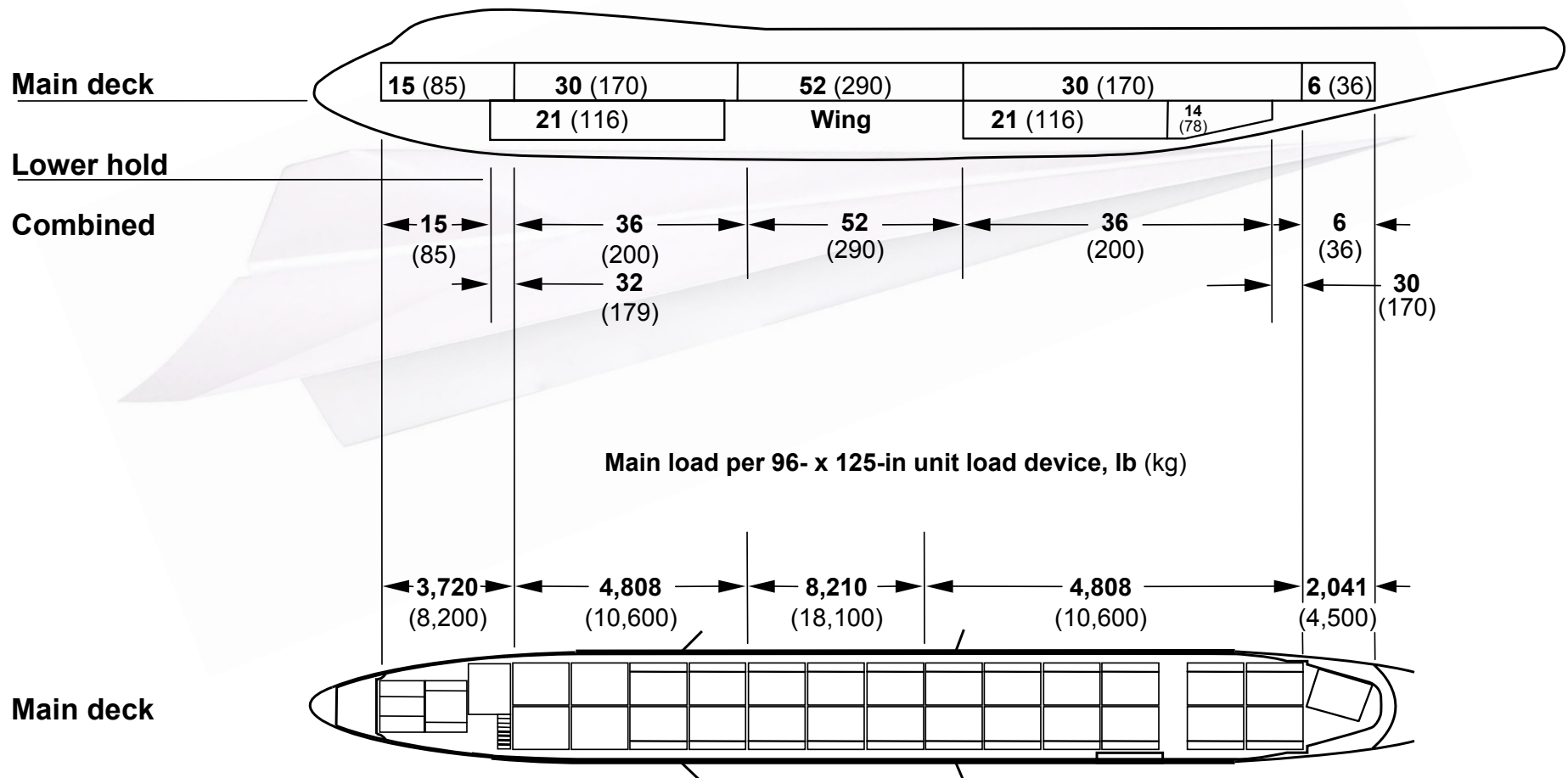

747-400/-400ER Freighter

Unmatched freight flexibility

StartupBoeing

