

# 767-300BCF cargo arrangements

Main deck configuration same as 767-300F

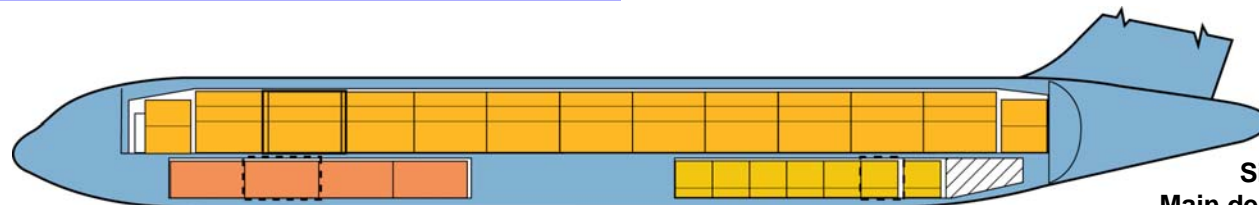

**Side-by-side 88- x 125-in  
Main deck ULD loading configuration**

<u>Qty</u>	<u>ULD type</u>	<u>Volume</u>
22	Contoured Type-A ULD @ 502 cu. ft. each	11,044 cu. ft.
2	Standard A2 ULD @ 420 cu. ft. each	840 cu. ft.
<b>Total =</b>		<b>11,884 cu. ft. (336.5 cu. m.)</b>

**Main Deck**

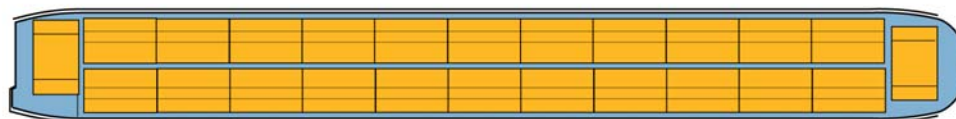

134- x 103-in door

**Lower Hold**

(4) 96- x 125-in @ 415 = 1,660 cu. ft.

134- x 69-in door

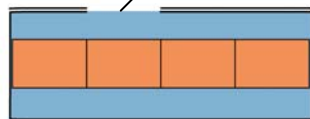

**Total**  
**3,840 cu. ft.**  
**(108.7 cu. m.)**

(14) LD-2 @ 125 = 1,750 cu. ft.

70- x 69-in door

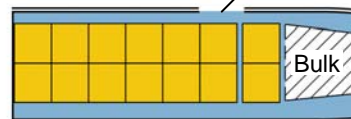

Bulk 430 cu. ft.

# The 767-300BCF main deck accommodates universal containers and pallets

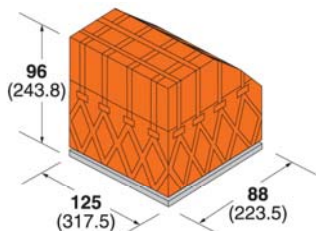

**Type A pallet \***

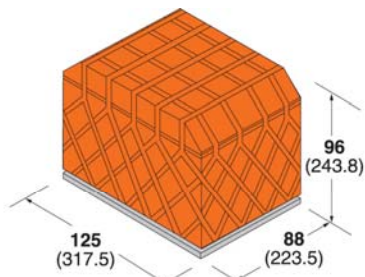

**M-1A pallet\***

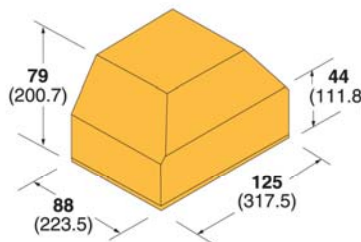

**Modified A-2 container**

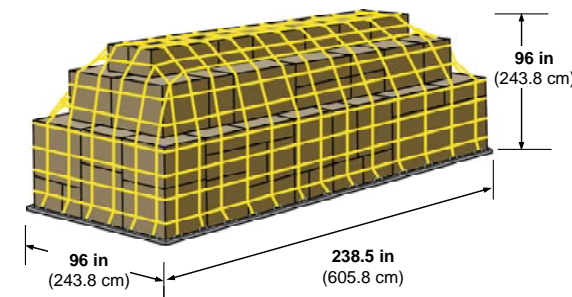

**G-code pallet\***

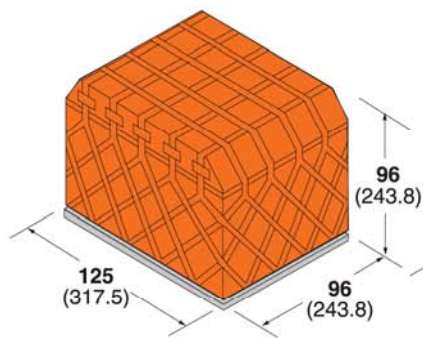

**M1 pallet**

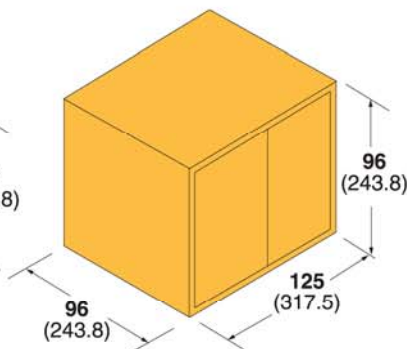

**M1 container**

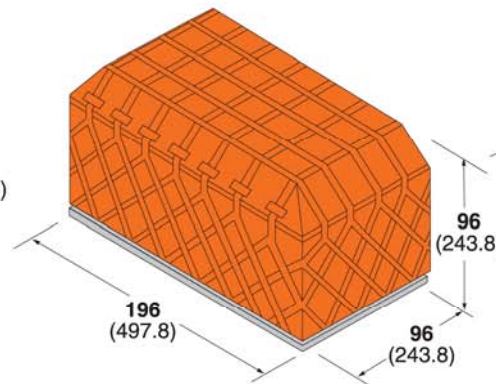

**Main deck pallet\***

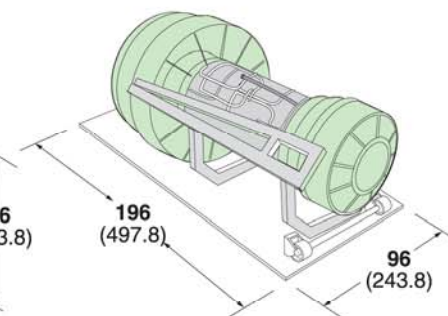

**Engine shipping pallet**  
Height: 101 in (256.5 cm) with  
PW4000 or GE CF6-80C2 engines

\*Loads contoured as required for clearance

- All units in inches (centimeters)
- Includes Military pallet capability (88x108-in)

# 767-300BCF longitudinal loading with M1-size containers

11 M1-size containers  
(maximum envelope)

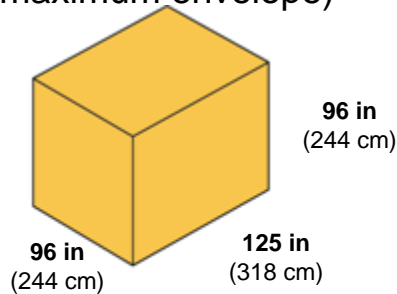

2 standard A2 ULD  
(maximum envelope)

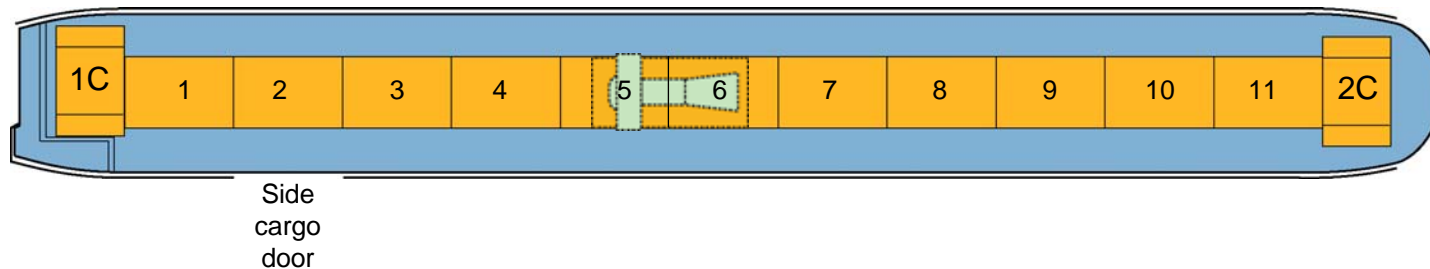
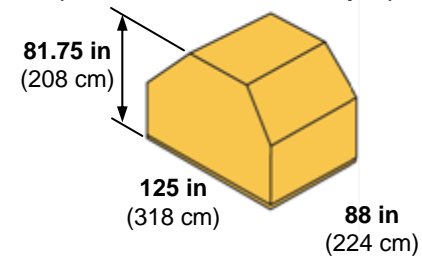

- Optional engine carriage in 5<sup>th</sup> and 6<sup>th</sup> positions

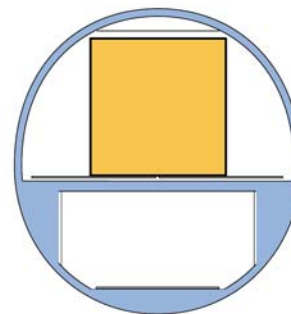
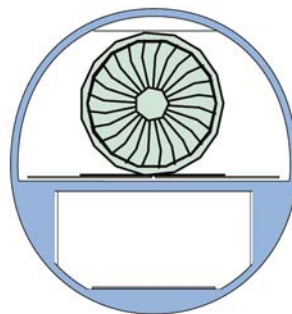

# 767-300BCF transverse loading with M-size pallets

14 M-size pallets  
(maximum envelope)

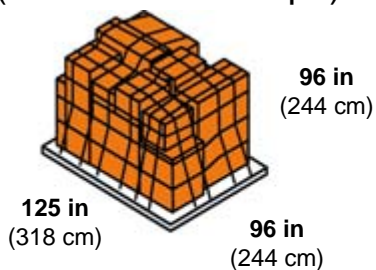

2 standard A2 ULD  
(maximum envelope)

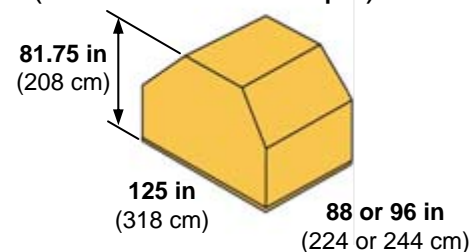

Side  
cargo  
door

- 14 A-size containers/pallets also available in transverse loading configuration

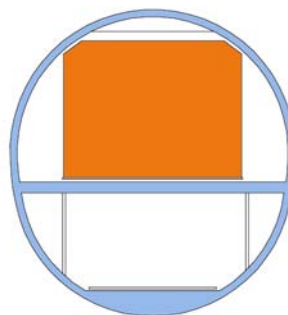

# 767-300BCF cargo arrangement with 88x108-in pallets/containers

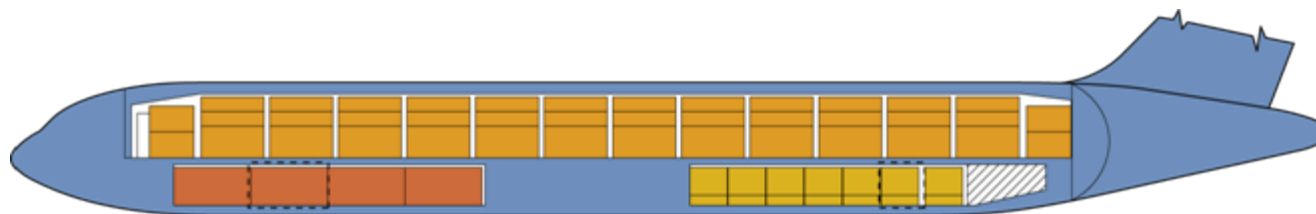

Main Deck



134- x 103-in door

## Side-by-side 88- x 108-in Main deck ULD loading configuration

<u>Qty</u>	<u>ULD type</u>	<u>Volume</u>
24	Contoured Type-B ULD @ 434 cu. ft. each	10,416 cu. ft.
2	Standard Type-B ULD @ 363 cu. ft. each	726 cu. ft.
<b>Total =</b>		<b>11,142 cu. ft. (315.5 cu. m.)</b>

# Flight compartment arrangement with rigid cargo barrier same as delivered on 767-300F

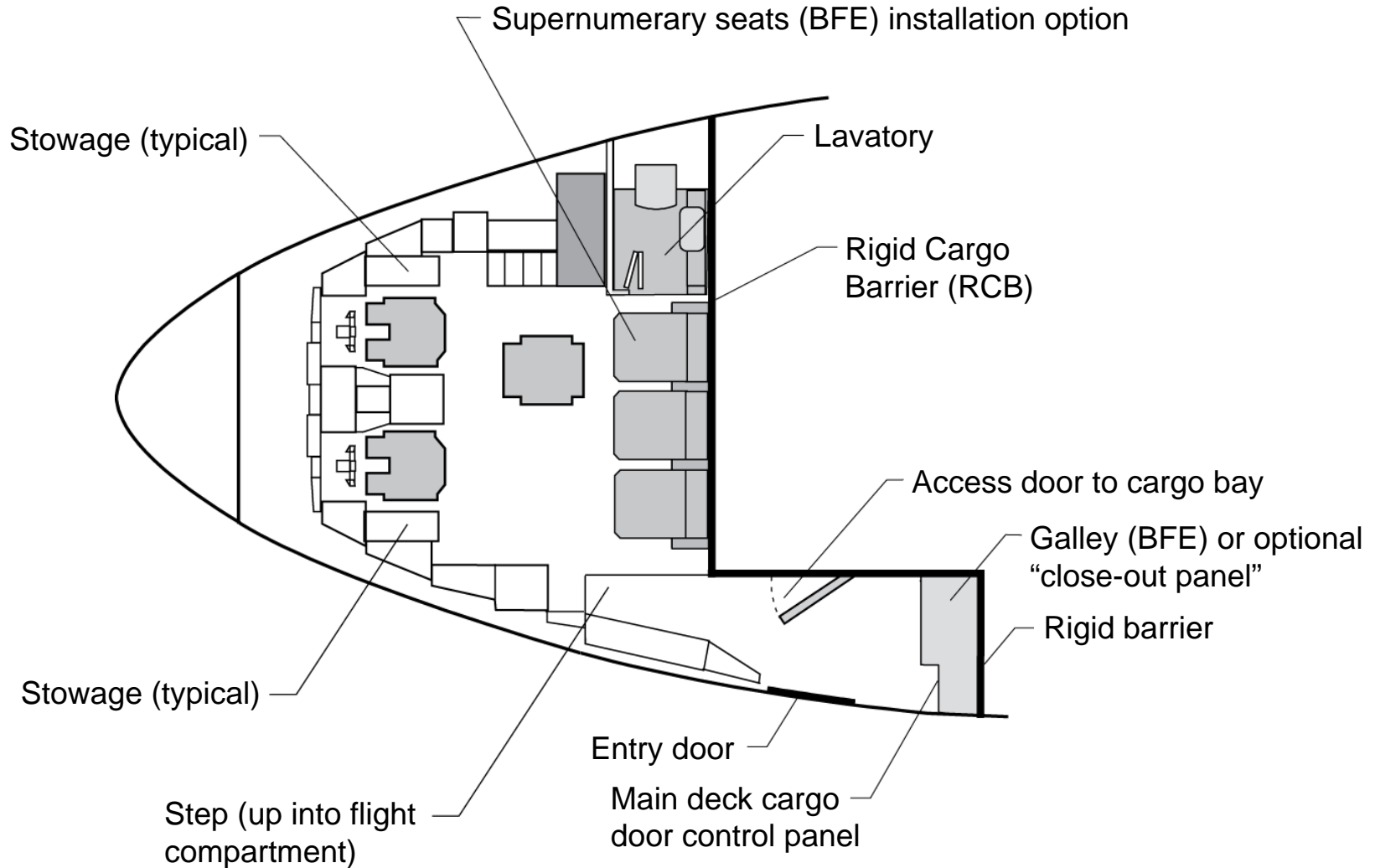

# Supernumerary configuration same as 767-300F

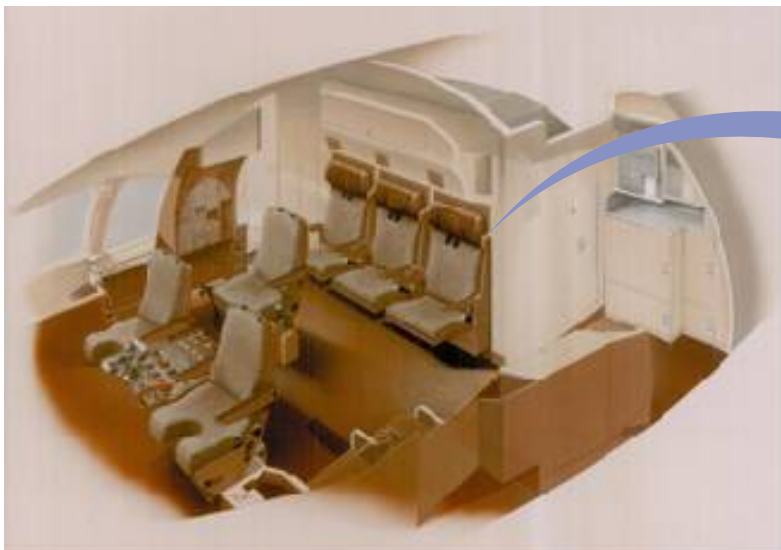

# Typical 767-300F/BCF galley (BFE)

Main deck cargo  
door control panel

Working surface with sump

Cargo bay access door

Waste container and  
gray water tank

Insert envelope  
(potential cold-food storage  
and miscellaneous stowage)

Optional close-out panel in  
lieu of BFE galley

