

The 777 Freighter carries 3-m (10-ft) high pallets

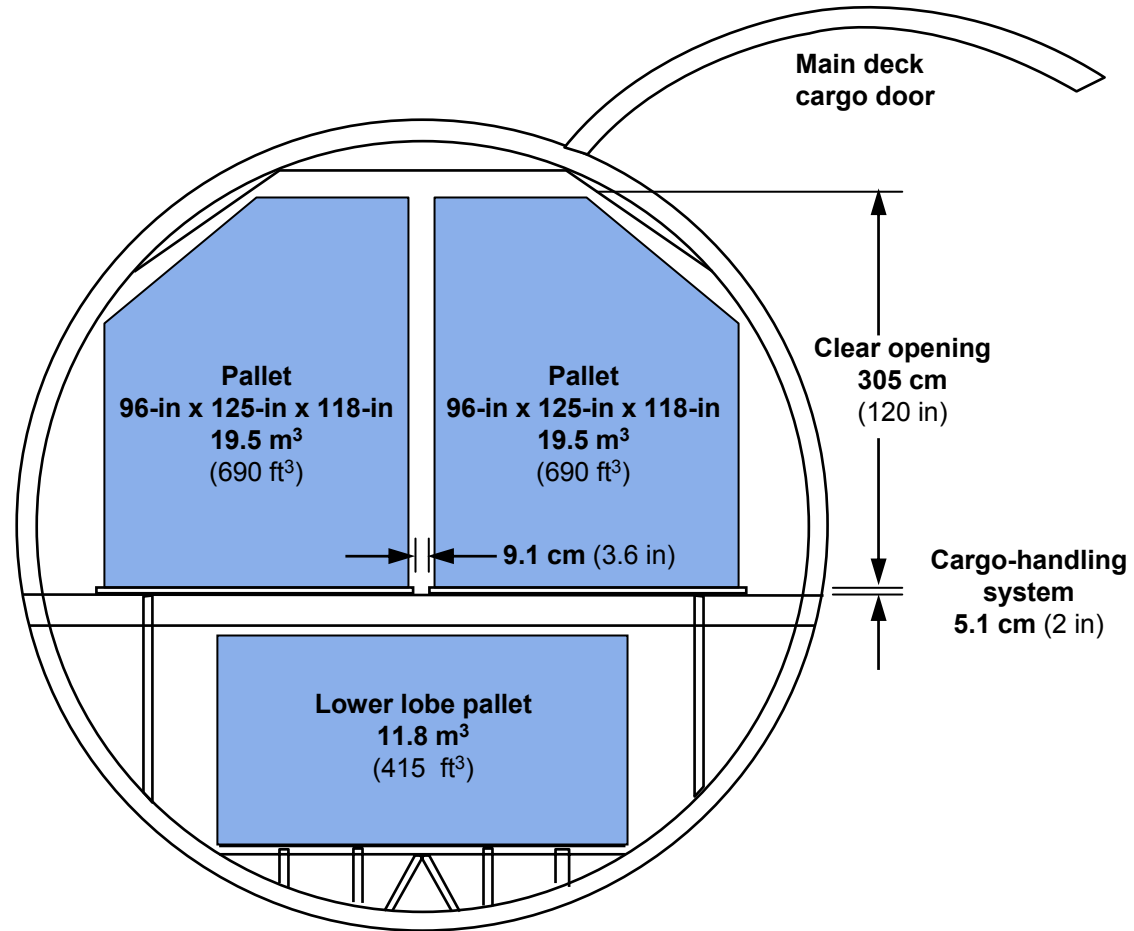

Looking aft