

98 great ideas

Meet some of Boeing's top innovators *By Cindy Naucler Glickert and Marcy Woodhull*

Innovation is alive and well at Boeing. This year, the company honored 98 of its top engineers, scientists and technologists from across the company for their ingenuity at the annual Boeing Special Invention & Technical Replication Awards events.

The ideas they've brought to life, as well as their innovative replications of previous inventions, are increasing product performance, maximizing productivity and enabling new business opportunities.

"We have a strong culture of innovation and creativity," said Martha Ries, vice president of Intellectual Property Management, the organization that works to identify, protect and leverage Boeing intellectual property. Ries noted that for the fourth year in a row, Boeing has been ranked the top U.S. patentee among aerospace and defense companies by the Patent Board, a leading patent

analysis group. The rankings are based on criteria such as quantity, technical strength and how quickly a patent becomes an asset.

"This year we recognized one of our largest numbers of inventors who have taken their ideas from vision to reality to enhance our products or services."

It is also the second year the company has honored outstanding replicators. The Technical Replication Award recognizes the transition of an existing technical capability to other programs.

"This award honors our enterprising teams of engineers who work across the breadth of Boeing's products, replicating technical solutions," said Amy Buhrig, vice president of Enterprise Technology Strategy. ■

cindy.n.glickert@boeing.com

On the following pages are stories about some of Boeing's top innovators. The complete list of those who were honored in 2010 with Boeing Special Invention & Technical Replication Awards can be found online: www.boeing.com/news/frontiers/archive/2010/december/i_eot.html

Lori Straus

Sanding an airplane to prepare it for painting requires strenuous work and creates an environmentally hazardous dust.

That's why a team of Boeing chemical engineers and material scientists worked together to develop a chemical process called the Activation Method Using Modifying Agent.

"It replaces hand sanding, which can potentially cause repetitive motion injuries, and it's cleaner for the environment," said Lori Straus, a Boeing Research & Technology materials scientist and Associate Technical Fellow in Everett, Wash.

The chemical agent is sprayed on the exterior surface of an airplane and acts as an adhesion promoter for the topcoat paint. Benefits of using the chemical agent include improved paint quality, faster production, the elimination of environmentally hazardous dust, and ergonomically safer work for painters. This new chemical material and process is currently being used on all Boeing commercial airplanes. ■ PHOTO: GAIL HANUSA/BOEING

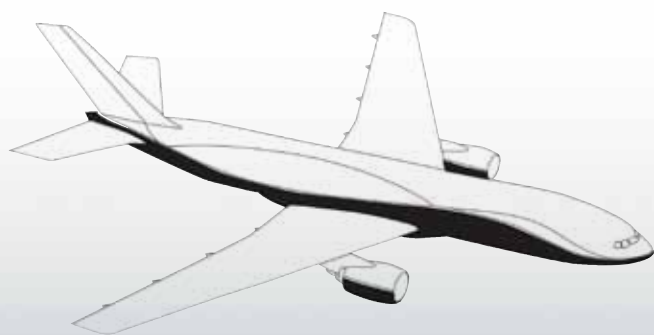

Marty Bradley

As part of its environment-related activities, Boeing is involved in developing biofuels for commercial aviation. So it made sense to replicate these efforts to support defense customers.

Marty Bradley, a Platform Performance Technology aerospace engineer with Boeing Research & Technology, was part of a team that received a Technical Replication Award for replicating its work on sustainable aviation biofuel.

"When I started working with biofuels in 2006, the U.S. Air Force was looking at making synthetic jet fuel from coal, which was not a smart environmental move," said Bradley, based in Huntington Beach. This year, with Boeing's assistance, the Air Force conducted biofuel flight demonstrations in its F-15 and C-17 aircraft. The U.S. Navy conducted a flight demonstration in the F/A-18 and the Royal Netherlands Air Force flew an AH-64D Apache helicopter using a biofuel blend.

In 2011, the American Society of Testing & Materials is expected to approve the use of sustainable aviation biofuel for commercial air travel. And the U.S. Defense Department is on track to certify the use of a 50 percent biofuel blend in all of its aircraft by December 2012.

"It just goes to show how applying good work on one program to another can leverage the strengths of Boeing," Bradley said. ■ PHOTO: PAUL PINNER/BOEING

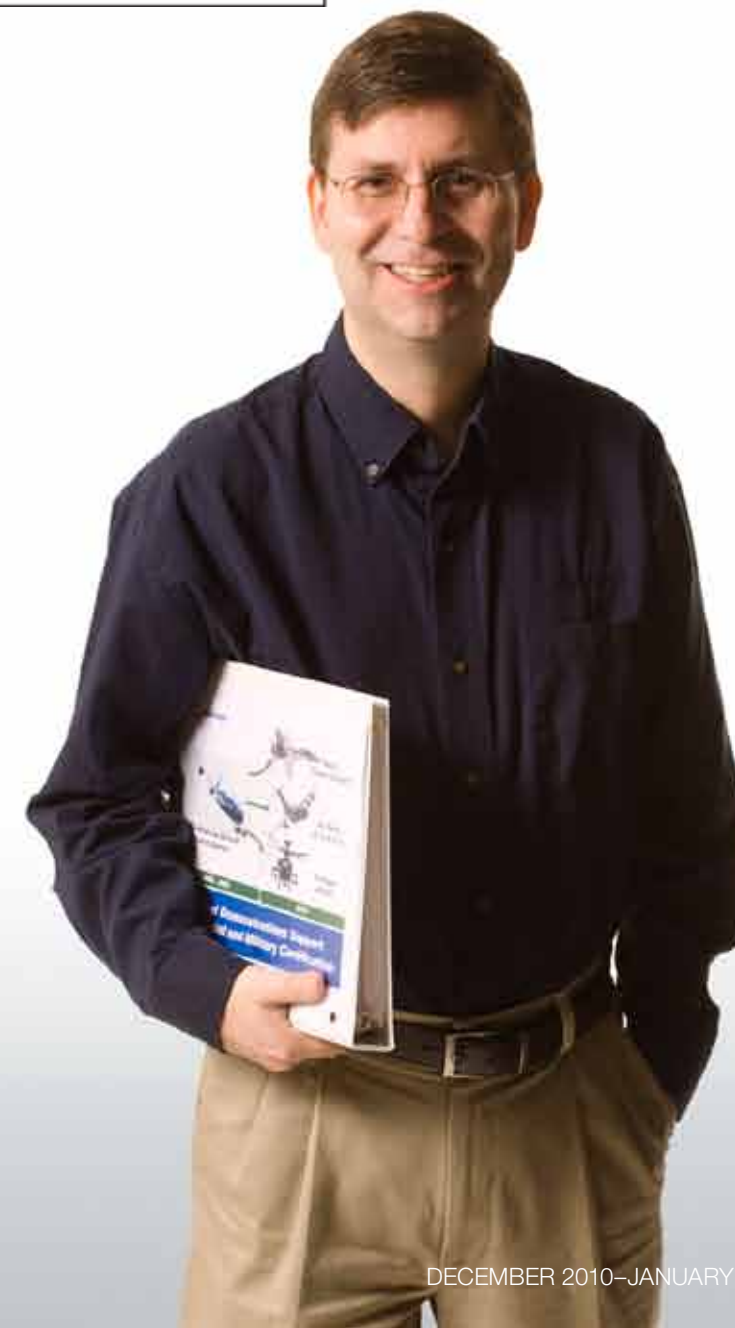
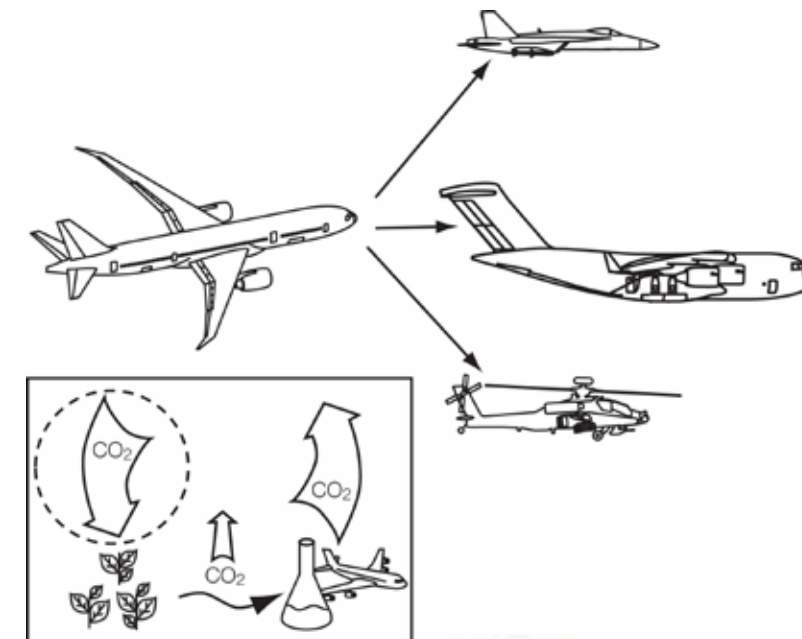



Shuguang Song

Determining the optimal schedule for when an aircraft requires maintenance work is not always obvious, and redundant repairs can cost operators time and money.

A recent Boeing-developed software system called the Maintenance Interval Determination and Optimization Tool takes the guesswork out of required maintenance by integrating an advanced statistical reliability and economic analysis module.

“It reduces the subjectivity in maintenance requirements and determines the optimal time for aircraft repair,” said Shuguang Song, a Boeing Research & Technology statistician in Seattle and member of the team that created the system.

The program was developed by a diverse team of innovators from across the company, including Boeing Research & Technology, Commercial Aviation Services, and Boeing Defense, Space & Security.

The maintenance tool has been approved by the Federal Aviation Administration for the 787 and 747-8 initial scheduled maintenance programs. It’s being replicated to support the Boeing Logistics Command and Control and the C-17 programs—which earned this invention a Technical Replication Award. ■ PHOTO: GAIL HANUSA/BOEING

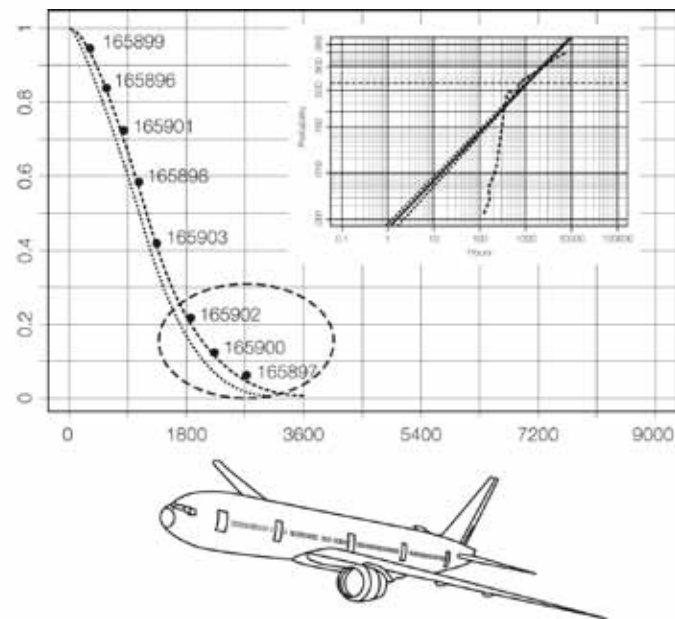

Robert Reynolds

Radio frequency waves are used to send and receive information to and from satellites, but errant wave scattering can cause serious problems within the constricted space of a satellite.

“Picture a flashlight beam that’s aimed straight ahead that allows no illumination to the sides,” said Robert Reynolds, an electrical engineer and Technical Fellow with Space and Intelligence Systems in El Segundo, Calif. “In very simple terms, we needed to find a similar way to confine radio frequency illumination to avoid parasitic interference.”

Reynolds and a team of engineers did just that. They invented the Radio Frequency Absorbing Fin Blanket, a carbon-based, thermal protective blanket shaped like a series of fins that absorbs unwanted radio frequency waves.

“Without this blanket, the satellite can get inadvertent signals from different directions,” Reynolds said. “The blanket effectively blocks and absorbs stray energy from payload components and the sides and back of the satellite antennas.”

The fin blanket has enabled Boeing to bid more efficiently on satellite programs, and is being widely used on 11 different satellite programs. It also has other potential applications, such as for use in ground-based antennas. ■ PHOTO: PAUL PINNER/BOEING

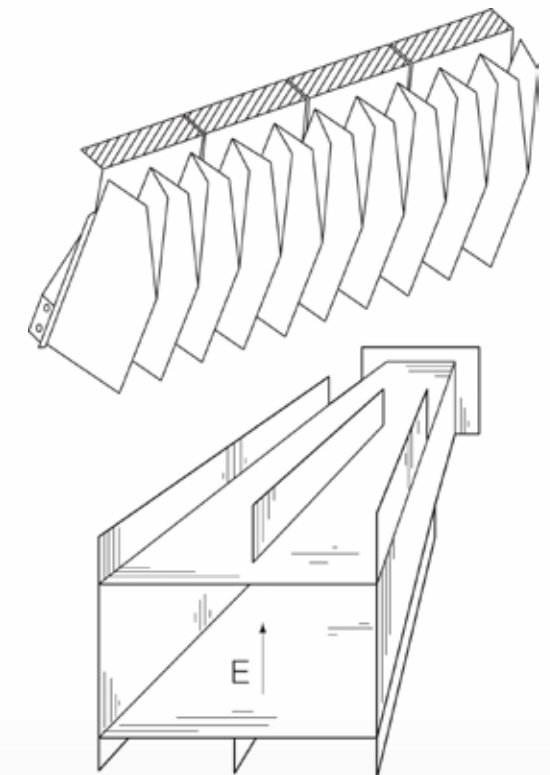

David Hilliard

Operating a ScanEagle unmanned aerial vehicle—used for surveillance in the battlefield—required intense operator control and coordination between the vehicle and its camera.

Taking automation to a new level, the inventors of the System and Method for Autonomous Tracking and Surveillance developed an electronic system that enables the aircraft's camera to automatically follow its target's destination and keep the vehicle in stealth mode and out of harm's way.

David Hilliard, a Boeing Defense, Space & Security unmanned systems engineer and ScanEagle operator, said he trained with U.S. Marines and worked with Boeing field service representatives to “identify the problem and understand the situation from the soldiers’ perspective.”

Working closely with the Marines, Hilliard and a team of Boeing engineers identified the problems, wrote software, and conducted simulations and flight testing. Undertaking these tasks also involved spending 18 months in Iraq as part of the Boeing ScanEagle operator team, Hilliard said. ■ PHOTO: ASSOCIATED PRESS

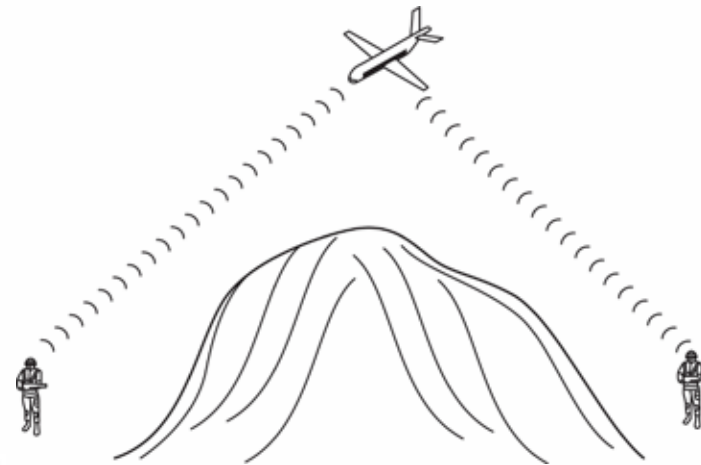

Dan Jockisch

Anyone who has flown on a commercial jetliner has probably turned on an overhead light or enjoyed the in-flight entertainment options. These and other amenities are available thanks to an airplane's electrical wiring systems, made up of wire bundles with components such as connectors and terminals. But installing these bundles can be tricky.

Faced with challenging wiring issues on the 777 Freighter Program, Dan Jockisch, a Commercial Airplanes design engineer, designed the Wire Bundle Pull Tool. The invention is a sliding piece of flat material, with Velcro around the edges that encases the wire harness assembly and can be easily threaded through complex structural assemblies. The pull tool, which can handle wire bundles that reach more than 50 feet (15 meters) long, reduces installation time, improves quality and enhances workplace safety.

Jockisch said his wife—“a great supporter of all my visions and projects”—sewed the first prototype. He brought it to his core group and they began brainstorming. From there he took it to an Accelerated Improvement Workshop.

“There are no dumb ideas, just different ways of looking at things,” Jockisch said. “Never be afraid to express an idea; that’s what our future is all about.” ■ PHOTO: GAIL HANUSA/BOEING

