

Public Meeting

Stormwater Controls at the Santa Susana Field Laboratory Outfalls 008 and 009

April 17, 2008

6:30 – 9pm

with 6:30 to 7:00pm Informal Meeting

Meeting Agenda

- Expert Panel
 - Panel members/scope/schedule
 - ENTS/design storm/site overview
- Public Meeting/Field Trip Recaps
- Respond to questions/comments from March public meeting
- Draft ENTS conceptual designs
- Design Storm Recommendation
- Wrap-up and Future Efforts

Expert Panel Members

- Dr. Robert Gearheart, P.E.
- Dr. Richard Horner (Prior Commitment tonight)
- Jonathan Jones, P.E.
- Dr. Michael Josselyn
- Dr. Robert Pitt, P.E.
- Dr. Michael Stenstrom, P.E.

Expert Panel's Scope of Work

- For outfalls 008 and 009 review site data and recommend natural Engineered Natural Treatment Systems (ENTS) capable of providing the required treatment to meet the final effluent limits.
- Recommend to the Board a site-wide design storm
- Public Involvement

SSFL NPDES Outfall Watersheds

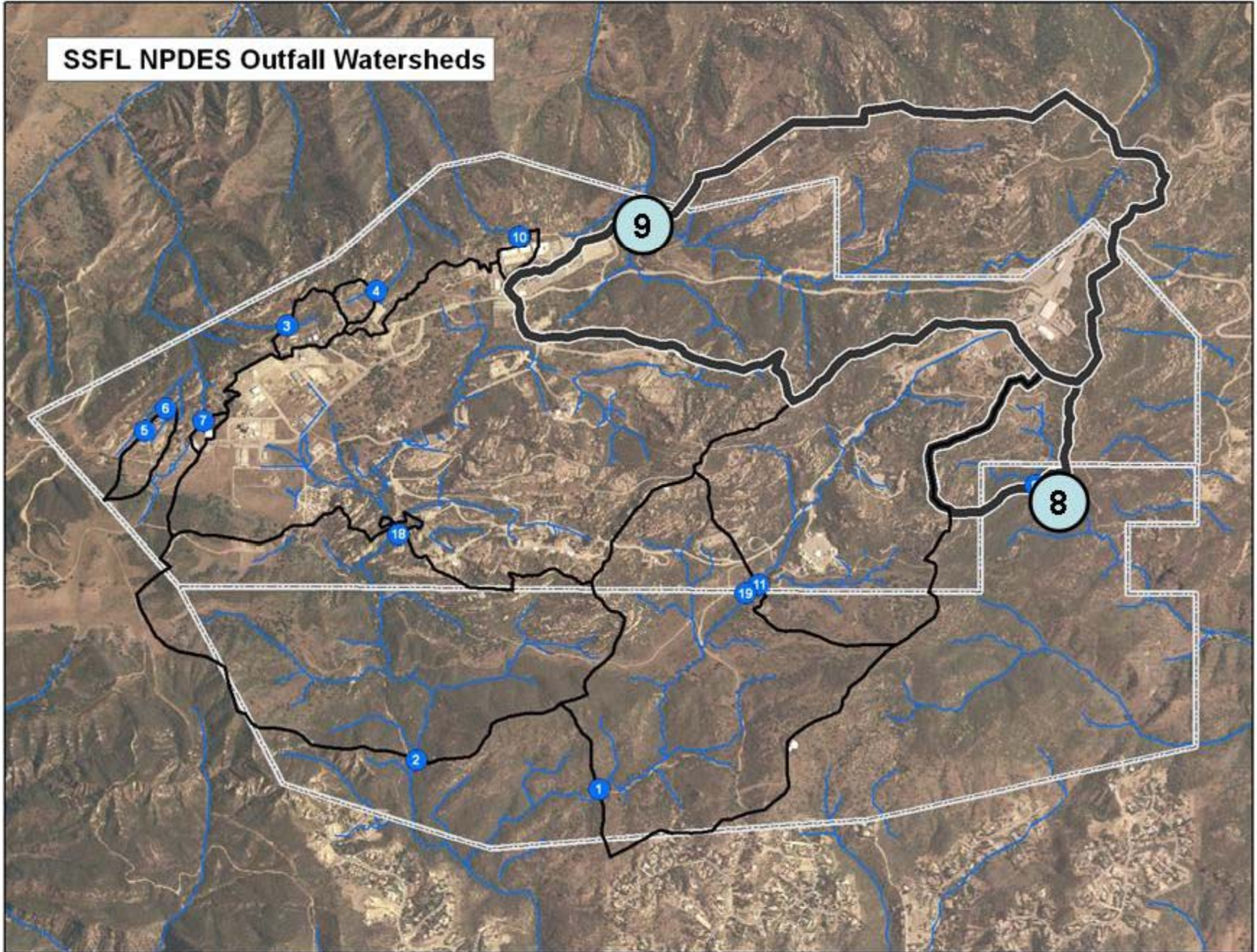

SSFL NPDES Outfall Watersheds

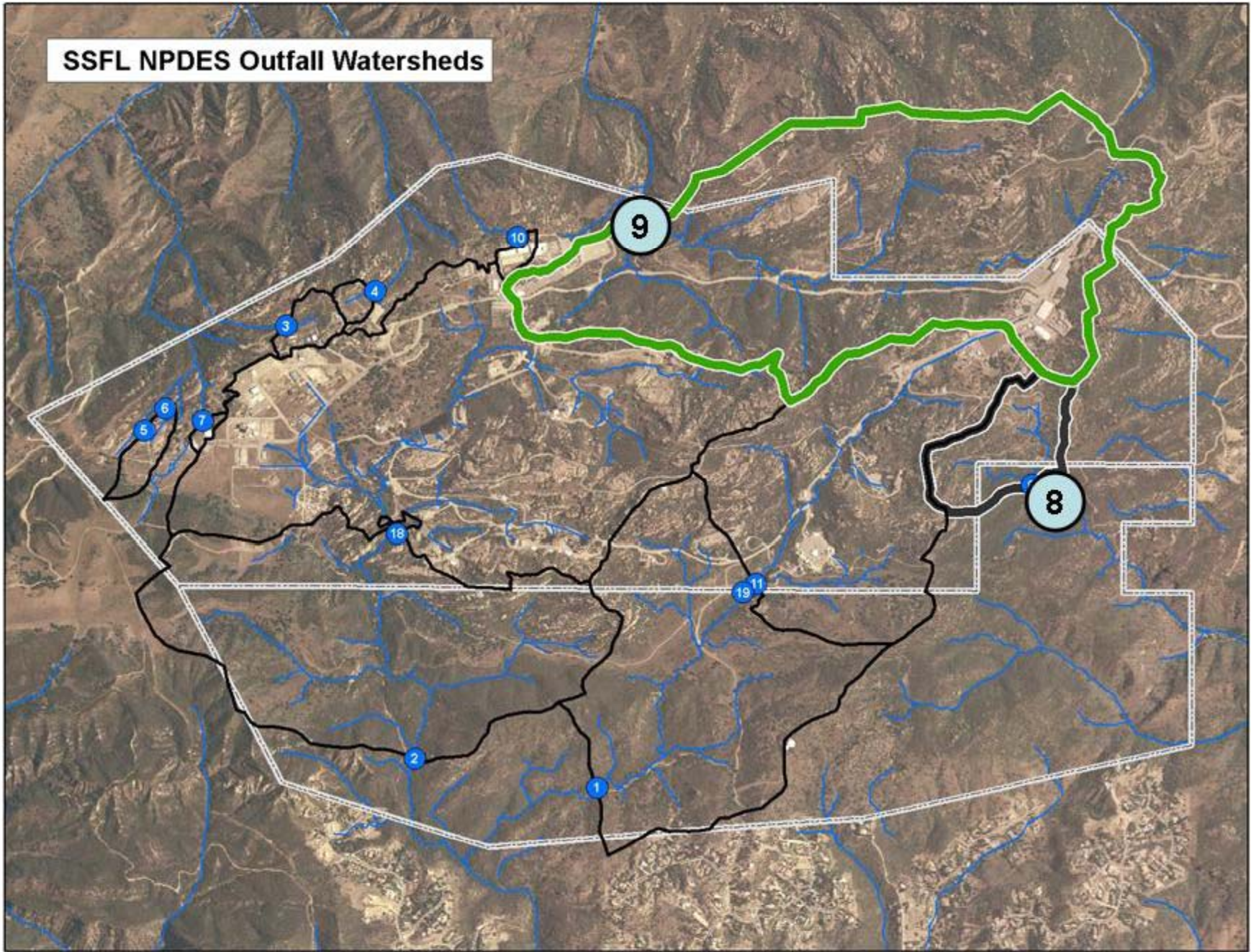

SSFL NPDES Outfall Watersheds

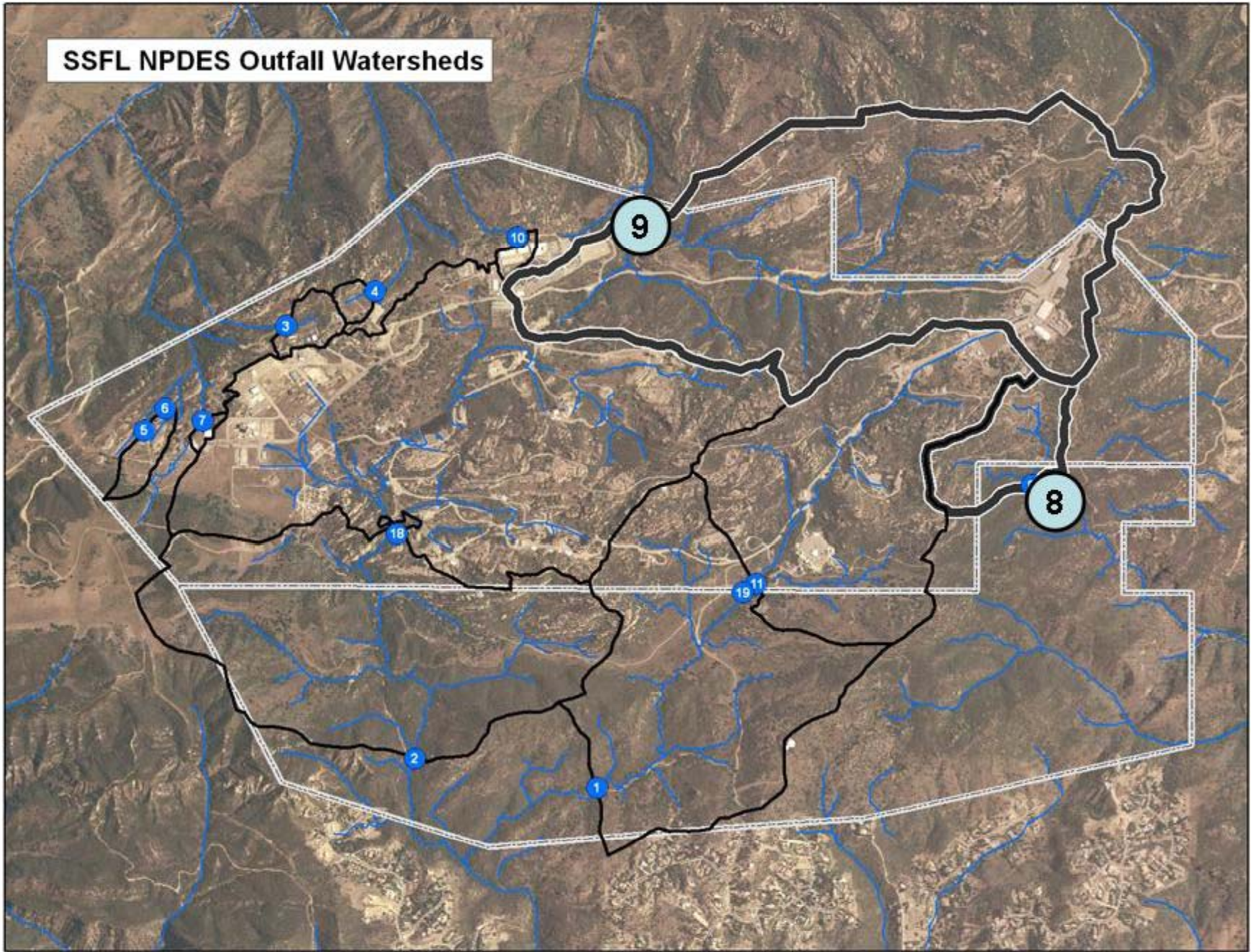

SSFL NPDES Outfall Watersheds

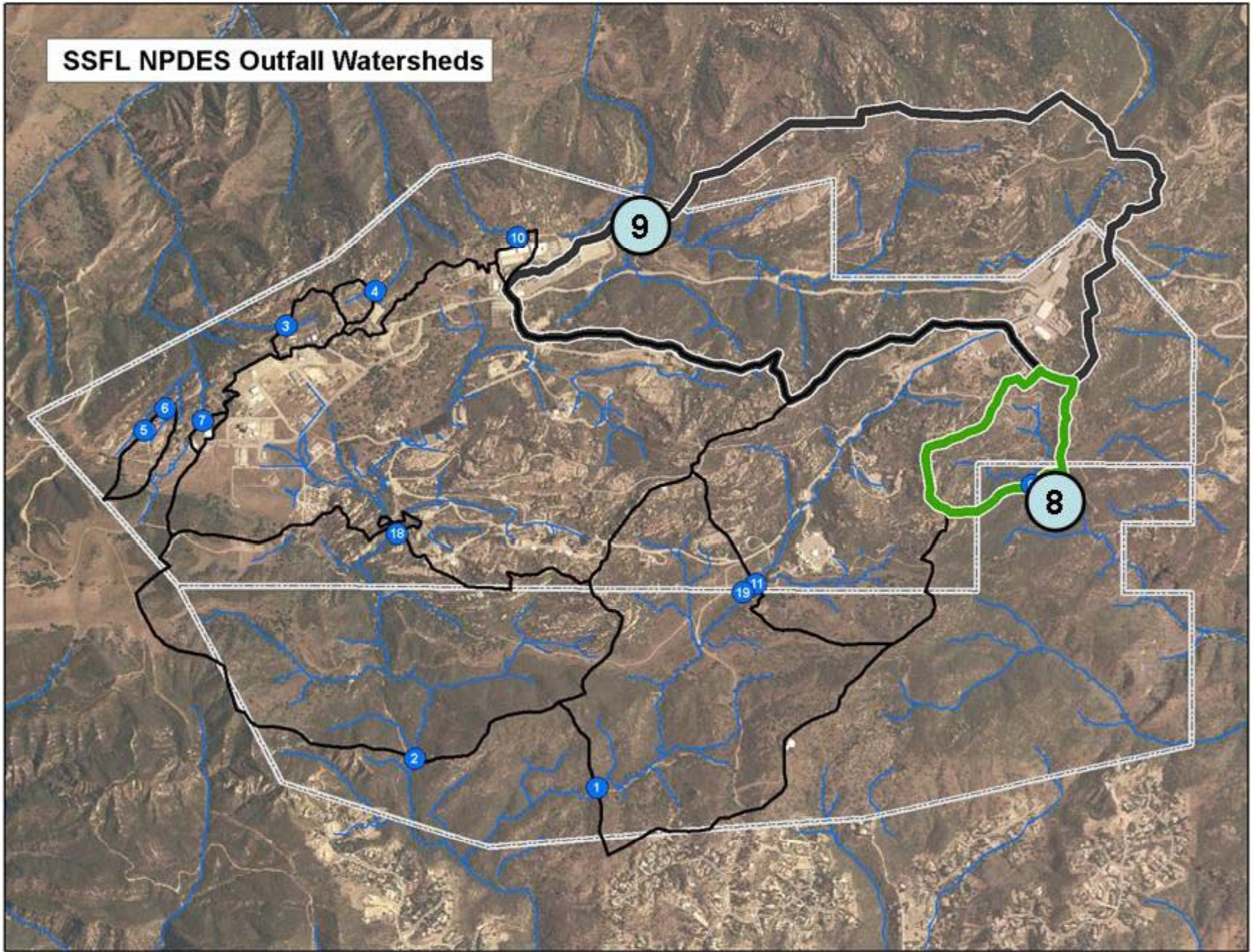

SSFL NPDES Outfall Watersheds

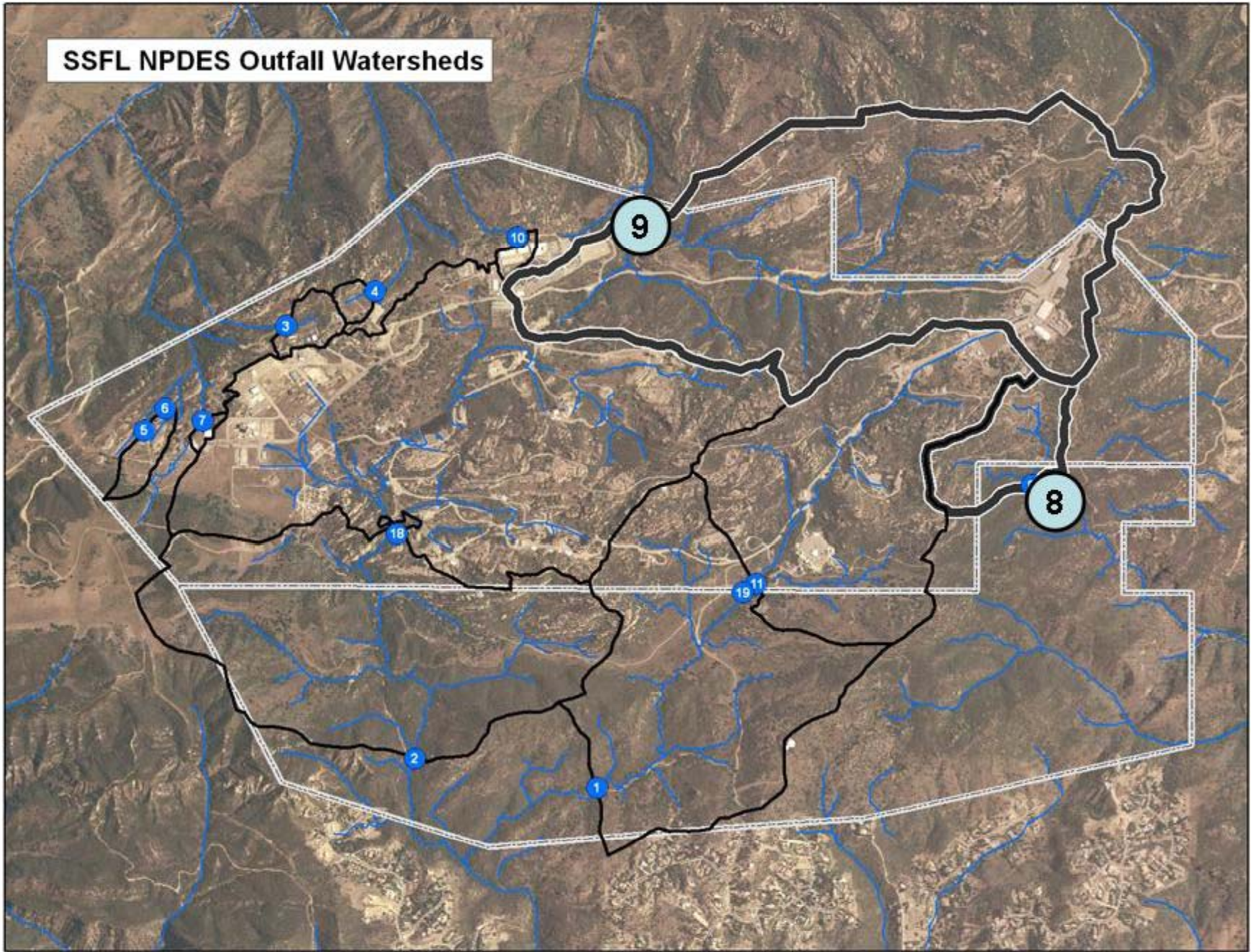

Expert Panel's Role

- Not charged to address RCRA or radiological site clean-up
- Provide participatory and technical models for other activities at the site

Engineered Natural Treatment Systems



**1: Site Controls
(reduce runoff volume)**

E.g.,
restore
un-used
impervious
surface
to natural
state



**2: Extended
Detention**



**3: Bio-
Filter**

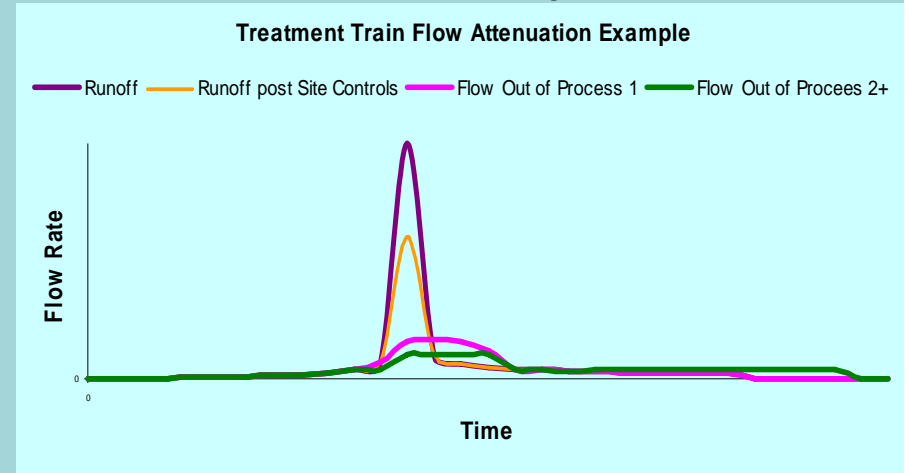

Engineered Natural Treatment Systems

Treatment Train Flow Attenuation Example

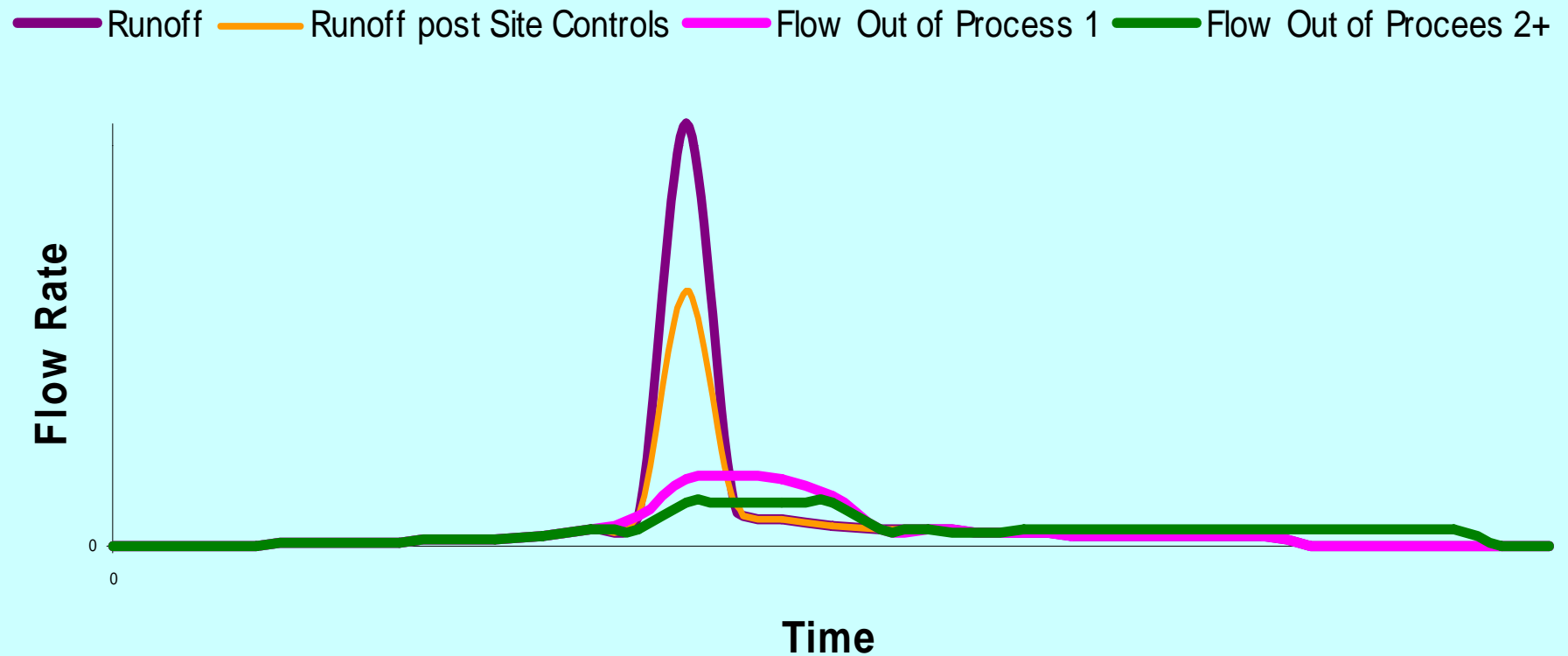

Engineered Natural Treatment System (ENTS) Treatment Train Concept

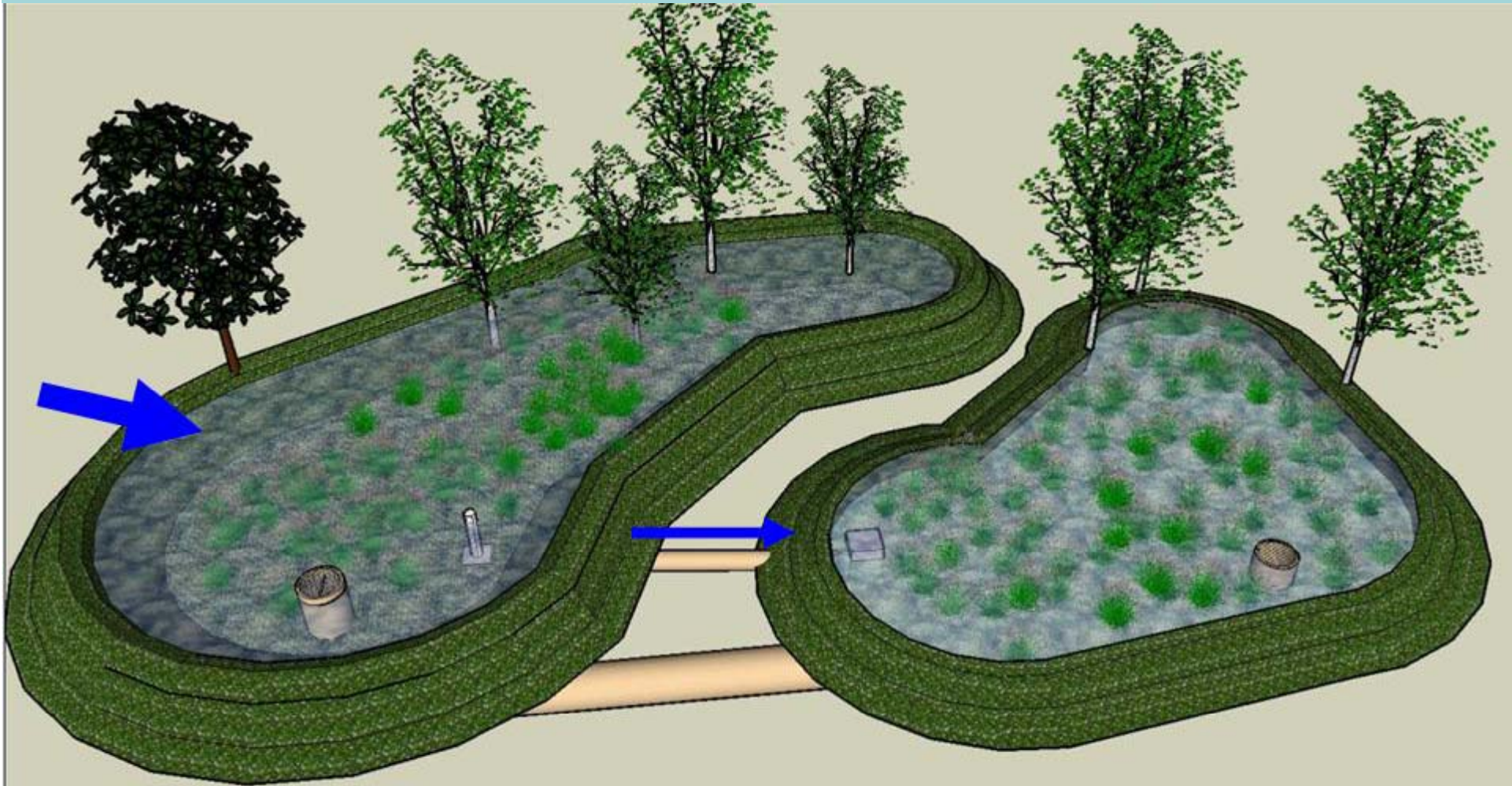

Treatment Train Concept

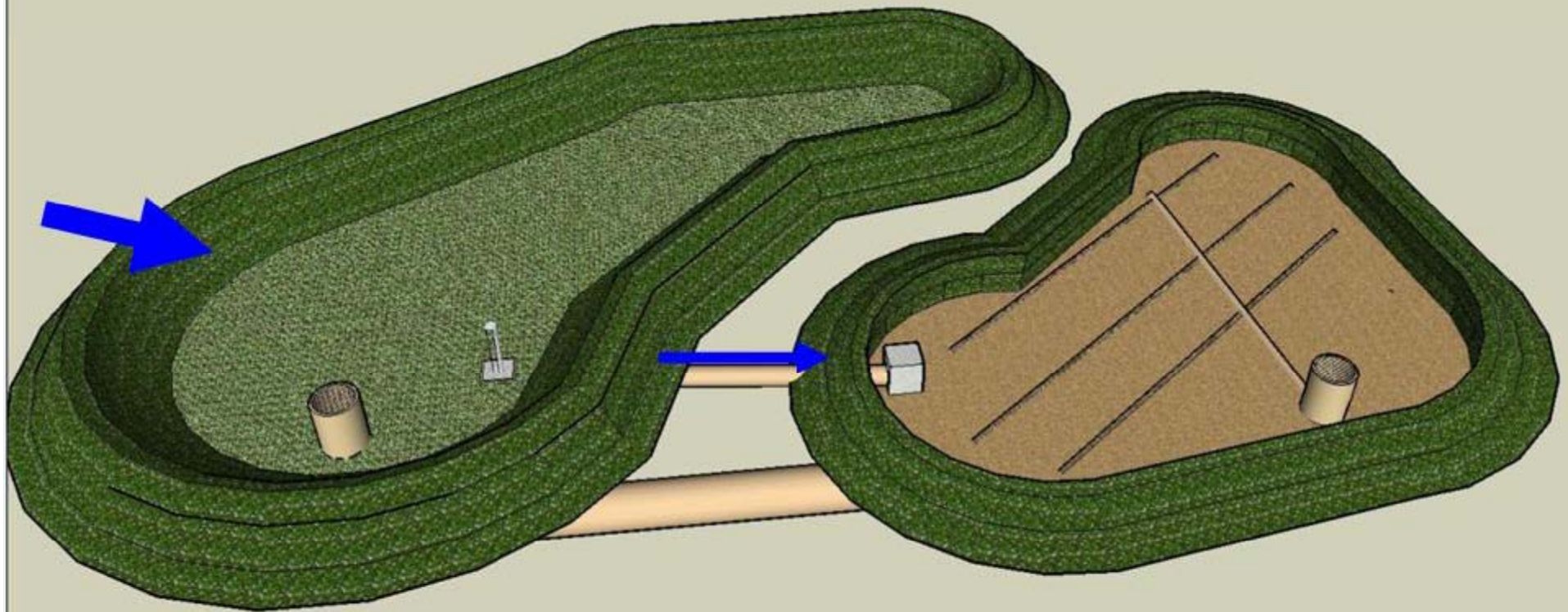

Design Storm

- Recommendation from Panel on maximum storm event to which numeric effluent limits apply
 - Numeric limits apply as enforceable limits during almost all storms
 - Numeric limits apply as benchmarks for large infrequent storms
 - Drawbacks outweigh benefits for designing treatment systems for all storm events

Expert Panel Work Plan Schedule

Tasks	Proposed Date
Design Storm Recommendation	Preliminary draft complete
ENTS Conceptual Designs Complete	May 15, 2008
ENTS Final Designs Complete	July 15, 2008
ENTS Permitting	August 15, 2008
ENTS Construction Begins	October 31, 2008
Final Permit Limits Become Effective	June 10, 2009

Public Involvement Component

- Public Participation Meetings
- Periodic reports to RWQCB on project status
- Project information posted on the Internet:

http://www.boeing.com/aboutus/environment/santa_susana/ents/index.html

- Public Field Trips

Expert Panel Public Meetings

Proposed Scope	Proposed Date
Panel introduction/Overview	Complete, January 22nd
Progress on design storm and ENTS selection & conceptual design	Complete, March 17th
Recommended design storm and conceptual ENTS designs	Tonight
Progress on ENTS implementation	September, 2008
Initial ENTS Performance Monitoring Results	Summer 2009

Board Presentations

- March 6th – Brief report on progress
- April 3rd – Longer update and discussion of ENTS and Design Storm

Recap of March Public Meeting

- Review of January Meeting
- Responses to questions and comments
- Public field trip opportunity announced
- Independent Expert Panel
 - Scope of work
 - Progress toward design storm recommendation
 - Progress on ENTS (Controls) selection
 - Panel future efforts and schedule
- Public input – Questions and Comments

Public Site Field Trip Summary

- Held Friday April 4th from 9am to noon
- 16 were on the field trip:
 - 8 public,
 - one Expert Panel member
 - 5 from Boeing,
 - and 3 outside consultants
- 008 and 009 watersheds visited
- Issues discussed:
 - Difficulty at building ENTS or other treatment at 009 outfall
 - The VOC fate and transport in terms of ENTS placement
 - The ENTS train concept on specific role each type of unit plays individually and term of the train arrangement
 - Monitoring and maintenance

Response to Questions and Comments from March Meeting

- Protectiveness of Permit
 - Regional Board sets Permit requirements to be protective of public health and aquatic life
- Monitoring
- Dioxin
- Radiological constituents
- ENTS construction at or near cleanup areas

Existing Monitoring in 008 & 009 Watersheds

- Existing NPDES compliance monitoring for stormwater discharges at the outfalls
 - Dioxin - Every sampling event
 - Radionuclides - Every sampling event
 - Includes Gross Alpha, Gross Beta, Combined Ra-226 & 228, Tritium, Strontium-90, K-40, Cs-137, & Uranium
 - Total metals – Every sampling event
 - Toxicity – acute annually, chronic 2X/year
 - Remaining USEPA priority pollutants (including VOCs) - annually
- Sampling conducted consistent with Regional Board-approved protocols
- Analyses conducted by State-certified analytical laboratories

New Monitoring in 008 & 009 Watersheds

- Proposed by Expert Panel and the project team:
 - Treatability stormwater samples taken
 - Additional rain gauges added
 - Manual flow measurements taken at outfall 009
 - Stream channel conditions mapped in 009 drainage
 - Soil characterization at each ENTS location
- ENTS monitoring plan to be developed
 - Influent & effluent composite sampling
 - Sediment, vegetation, and groundwater sampling being considered

Dioxin Summary

TCDD TEQ in Stormwater at Outfalls 008 & 009

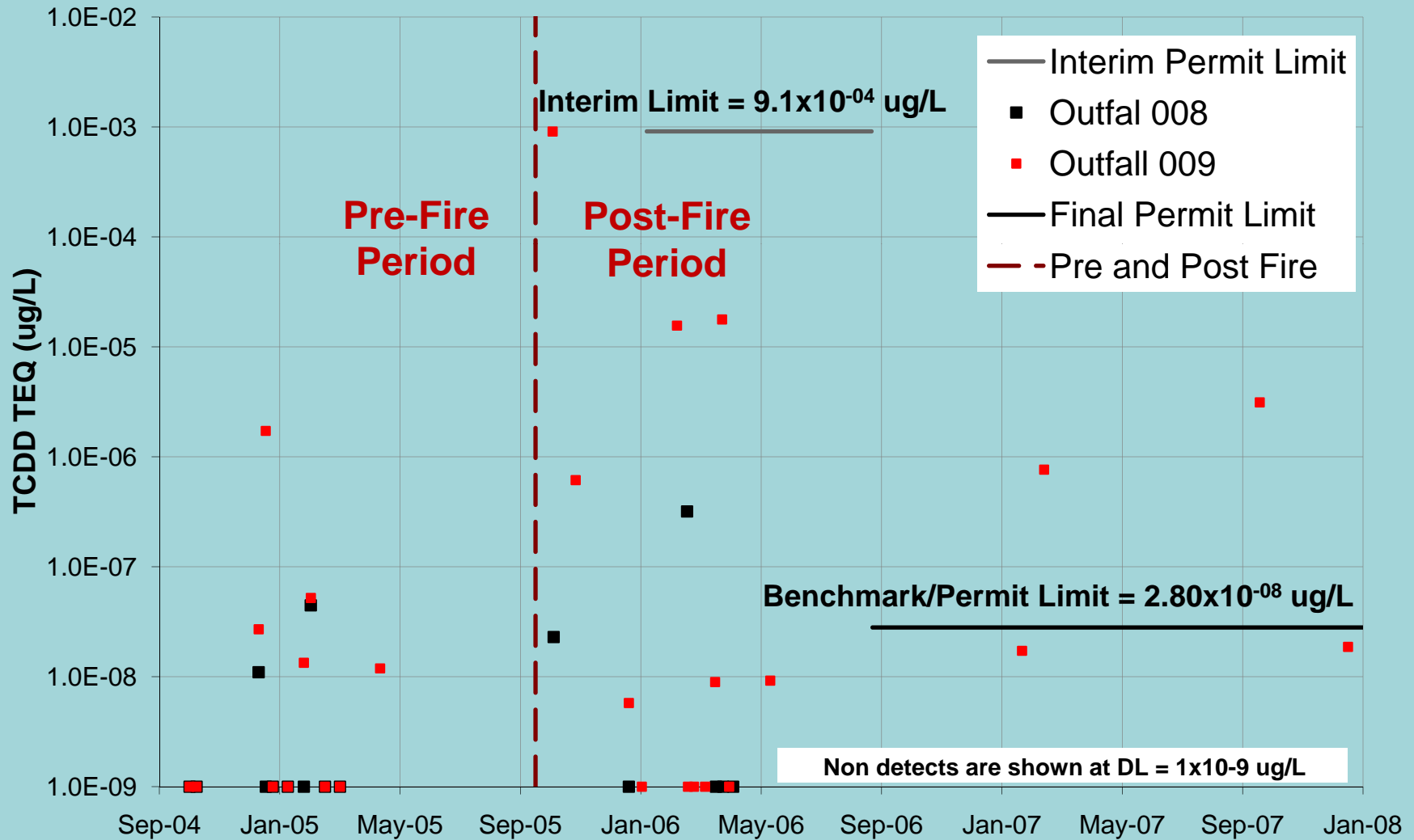

Radiological summary

Gross Alpha in Stormwater at Outfalls 008 & 009

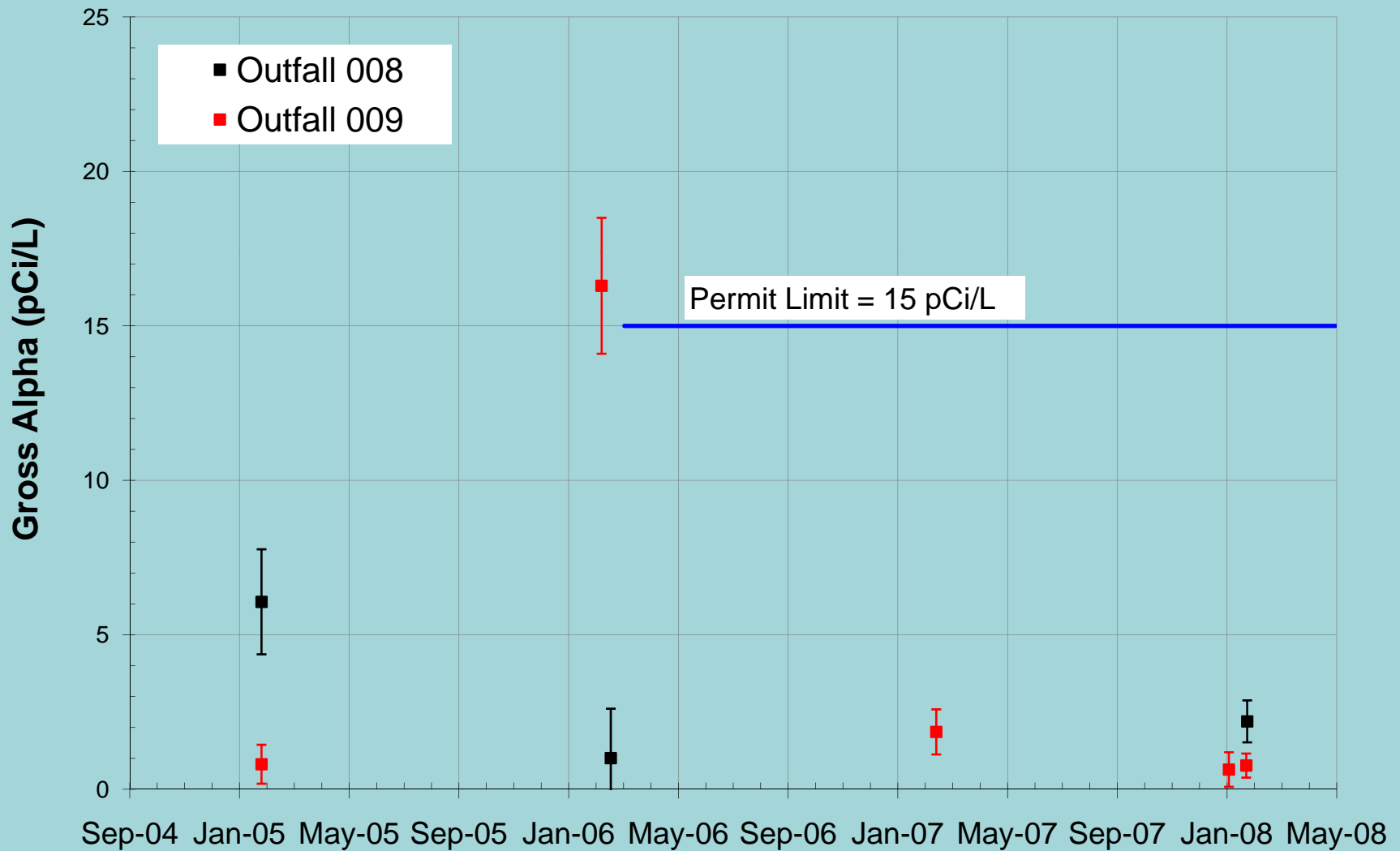

Radiological summary

Gross Beta in Stormwater at Outfalls 008 & 009

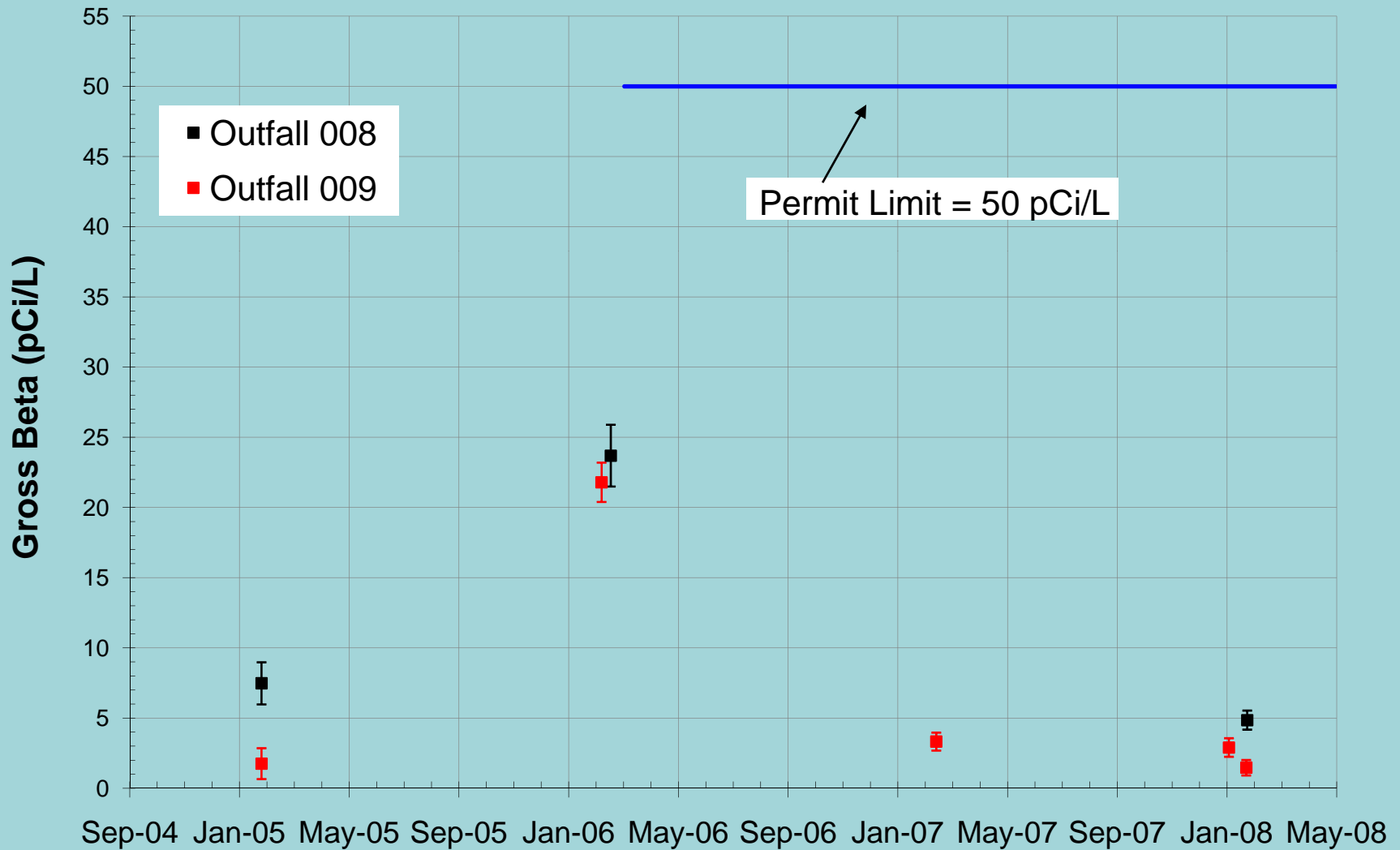

Preliminary Plan for ENTS Construction at or Near Cleanup Areas

- Some ENTS construction will be done in contaminated areas
- Construction will require:
 - Current sampling to satisfy data gaps
 - Additional sampling at time of construction
 - Removal of contaminated soils below and around ENTS footprints
 - Avoiding infiltration from ENTS to groundwater plumes
 - Avoiding interference with future vapor treatment plans

Questions about March Meeting Follow-up?

Meeting Agenda

- Expert Panel
 - Panel members/scope/schedule
 - ENTS/design storm/site overview
- Public Meeting/Field Trip Recaps
- Respond to questions/comments from March public meeting
- **Draft ENTS conceptual designs**
- Design Storm Recommendation
- Wrap-up and Future Efforts

008 and 009 Watersheds

Guiding Principle

- The Panel recommends control and treatment occur throughout the Outfall 008 and 009 watersheds, including off-site areas, such that
 - All feasible areas that can be used for volume reduction and treatment are used to help ensure compliance at the outfall
 - Sub-regional and critical source locations as large as possible
 - Also include source controls

Revised ENTS "Treated Area" Map

Draft Preliminary and Subject to Change

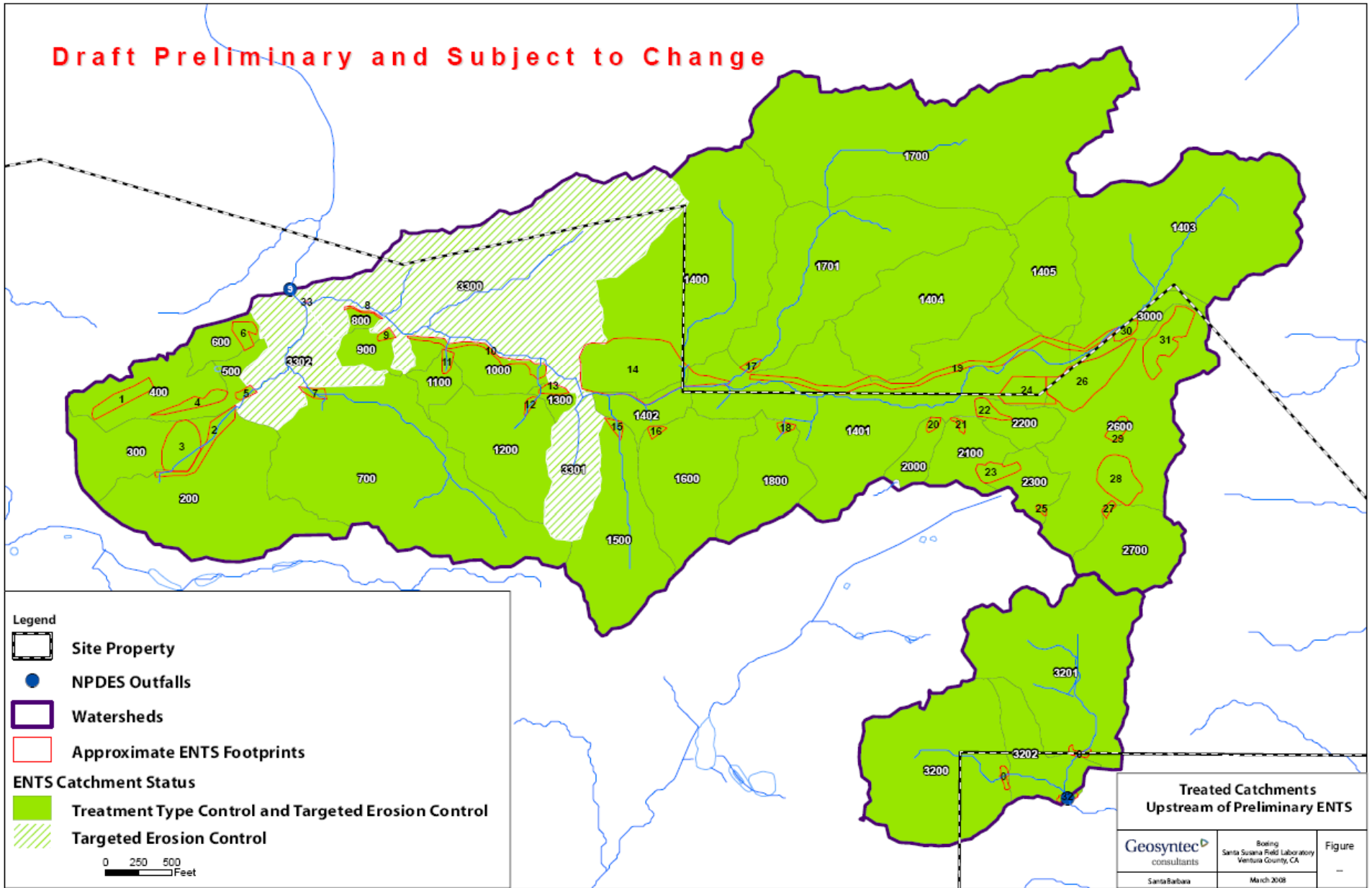

“Treatment Train” Approach

- Combine controls in series to treat runoff for multiple constituents and protect downstream controls
- Reduce peak flows to optimize treatment
- Include “polishing” enhancements (media additions, BMP soils amendments, etc.)
- Optimize unit processes and overall system design
 - redundancy and complementary processes
- Detain and slow runoff from watershed to maximize space-limited treatment at outfall 009

Preliminary ENTS Footprints, Watersheds 008 and 009

**Preliminary draft
Subject to change**

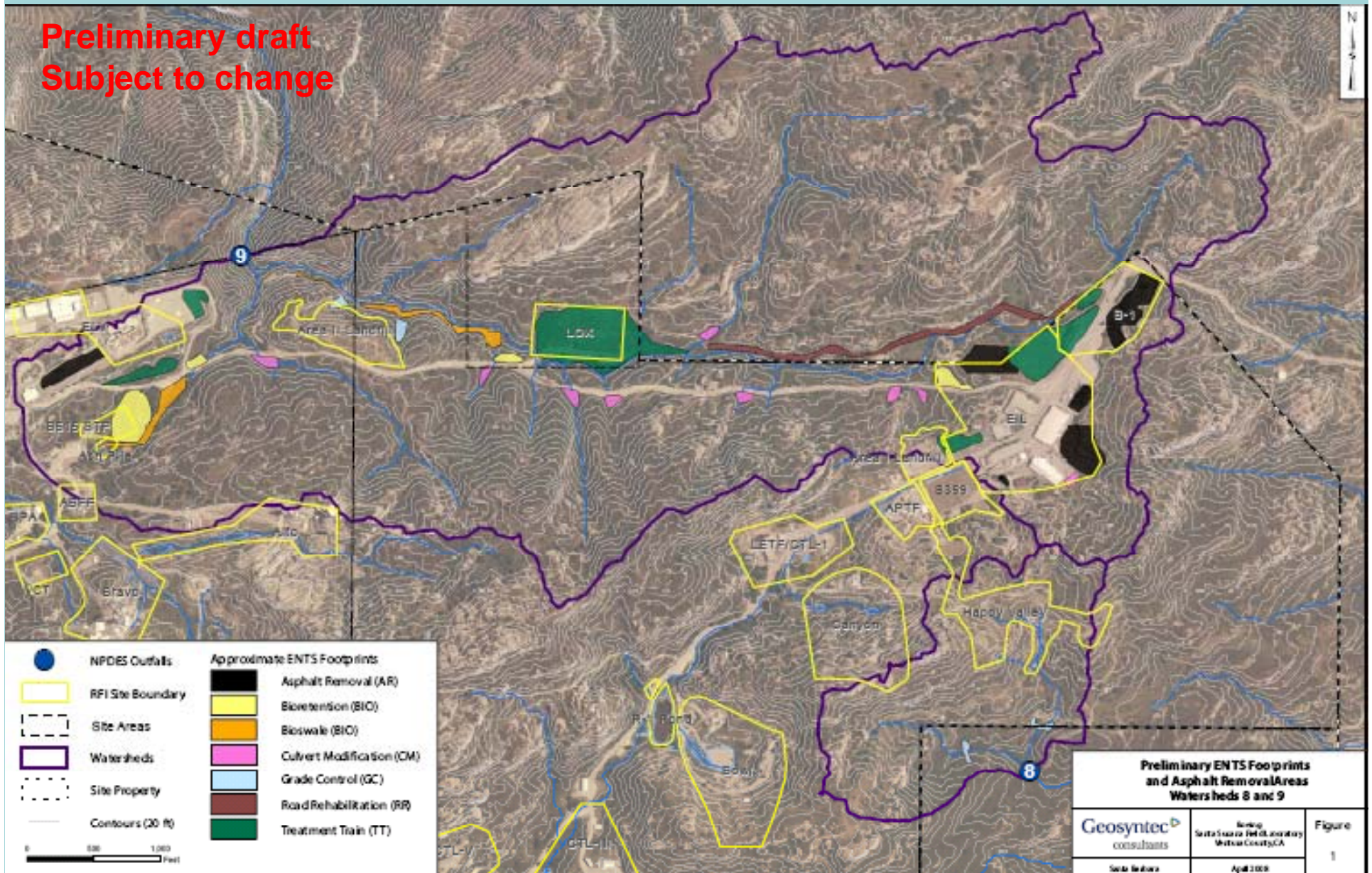

Draft ENTS

Conceptual Designs

- Conceptual Design is an initial approach:
 - Footprint
 - Basic structures and concepts
 - Cut/Fill rough quantities
- All proposed controls located off Boeing property are subject to landowner approval (pending)
- Later design phases

Phase I - Stormwater Maintenance and Asphalt Removal Projects – Immediate Implementation

**Preliminary draft
Subject to change**

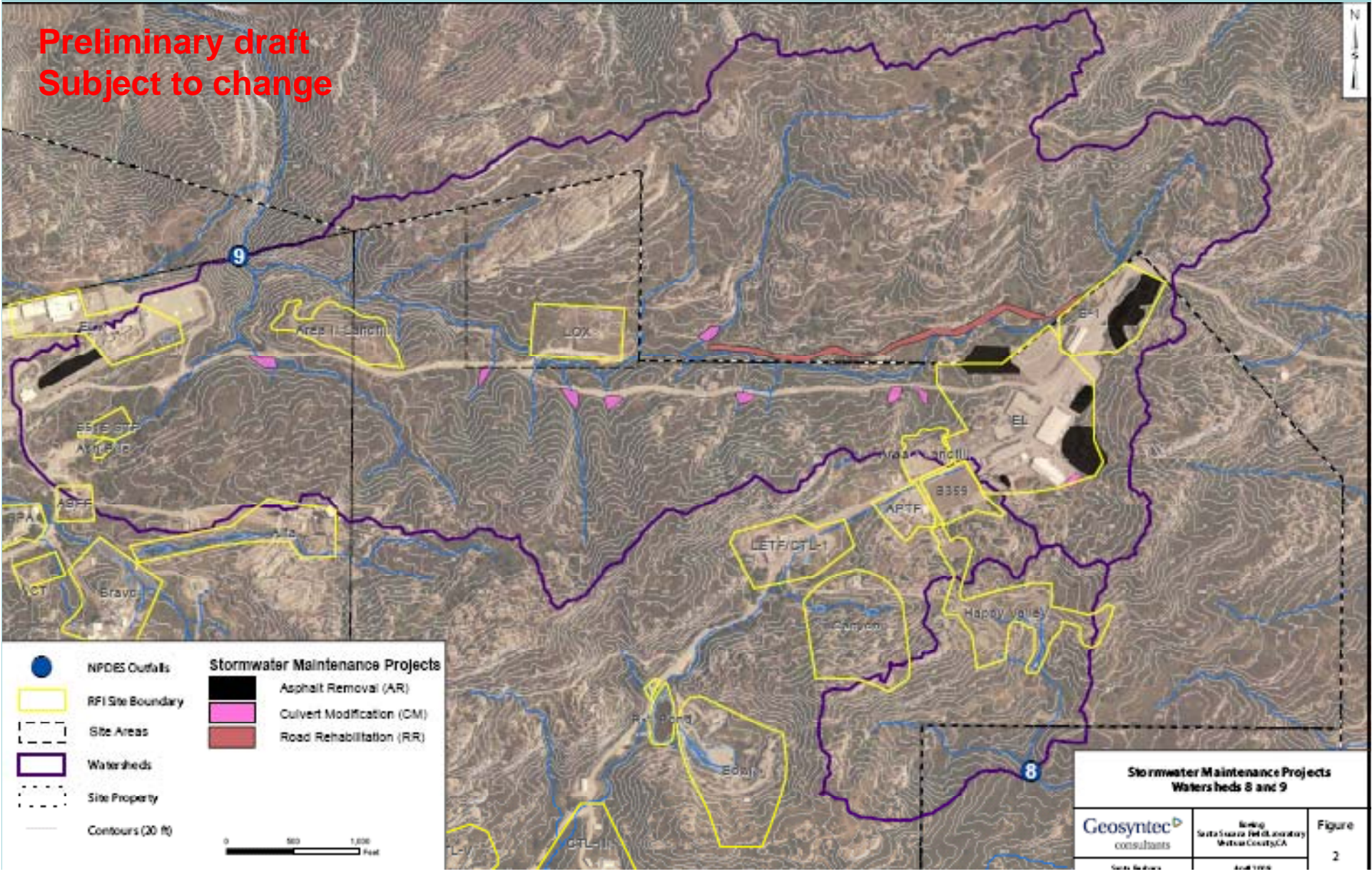

Conceptual Design Key Map

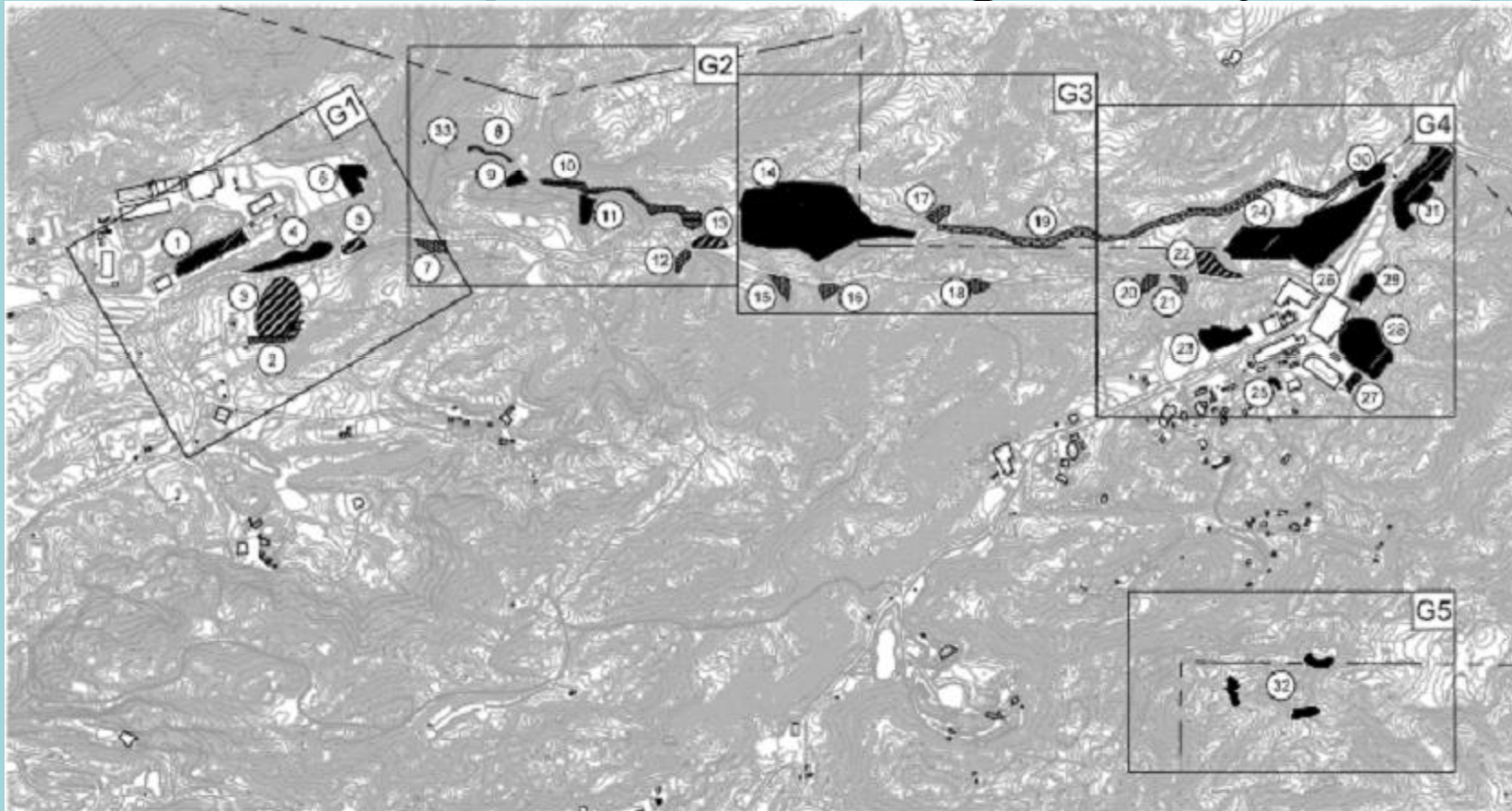

KEY MAP

LEGEND	
	EXISTING GROUND CONTOUR (FEET)
	PROPERTY LINE
	ENT NUMBER

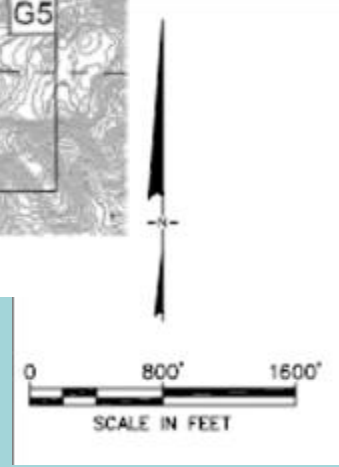

G1- 009 West (NASA Property)

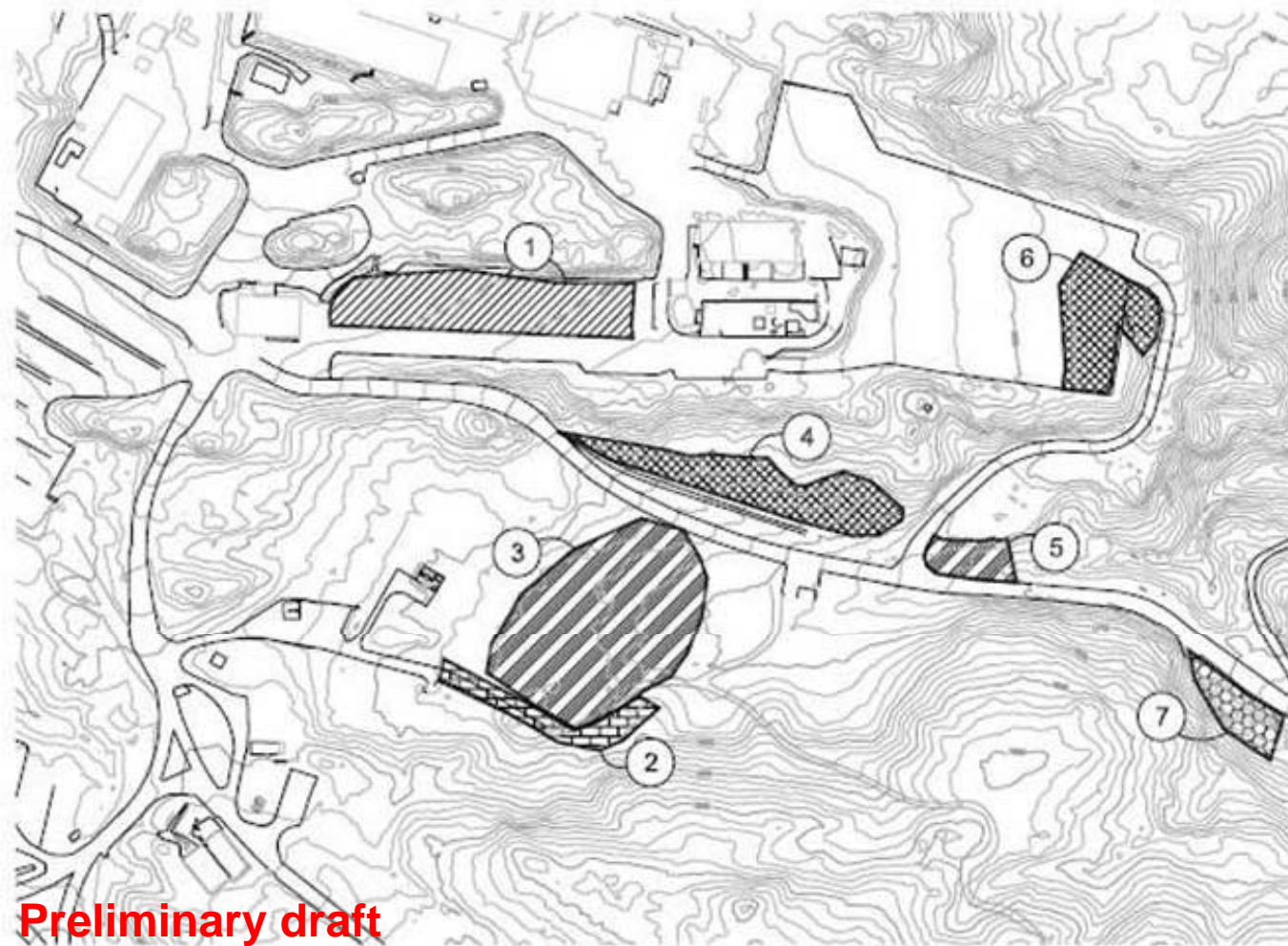

LEGEND	
— 730 —	EXIST. GROUND CONTOUR (FEET)
- - - -	PROPERTY LINE
②	ENT NUMBER
[Diagonal Hatching]	CULVERT MODIFICATION
[Diagonal Hatching]	ASPHALT REMOVAL
[Diagonal Hatching]	BIORETENTION
[Diagonal Hatching]	TREATMENT TRAIN
[Diagonal Hatching]	BIOSWALE
[Diagonal Hatching]	ROAD REHABILITATION
[Diagonal Hatching]	GRADE CONTROL

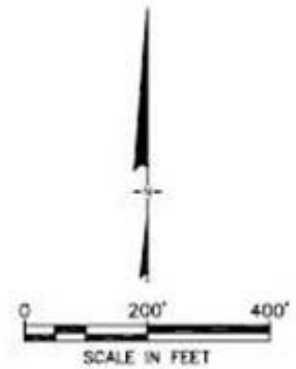

Preliminary draft
Subject to change

G2- 009 West Center (Partial NASA Property)

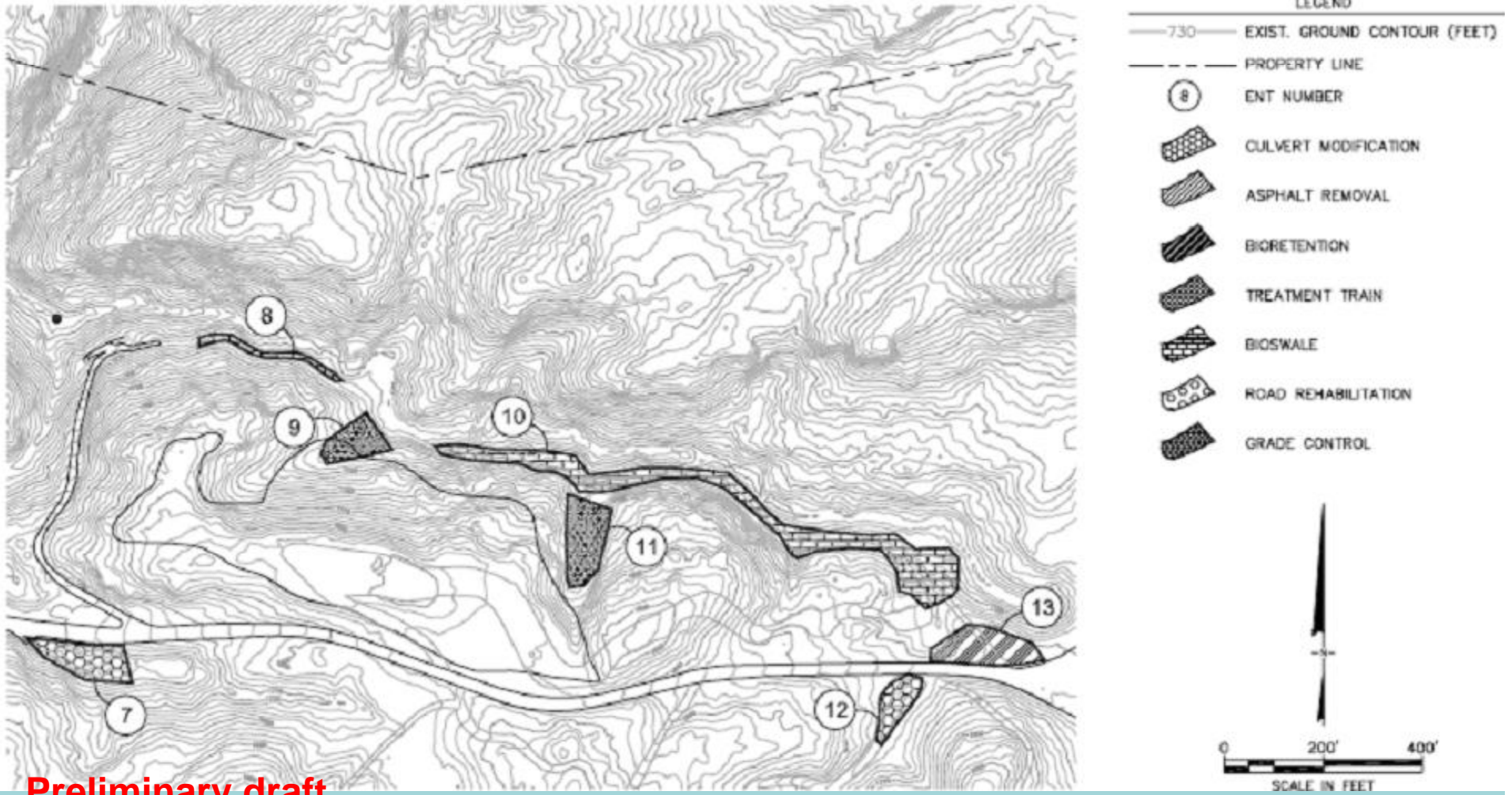

Preliminary draft
Subject to change

G3-009 LOX (NASA & Sage Ranch Properties)

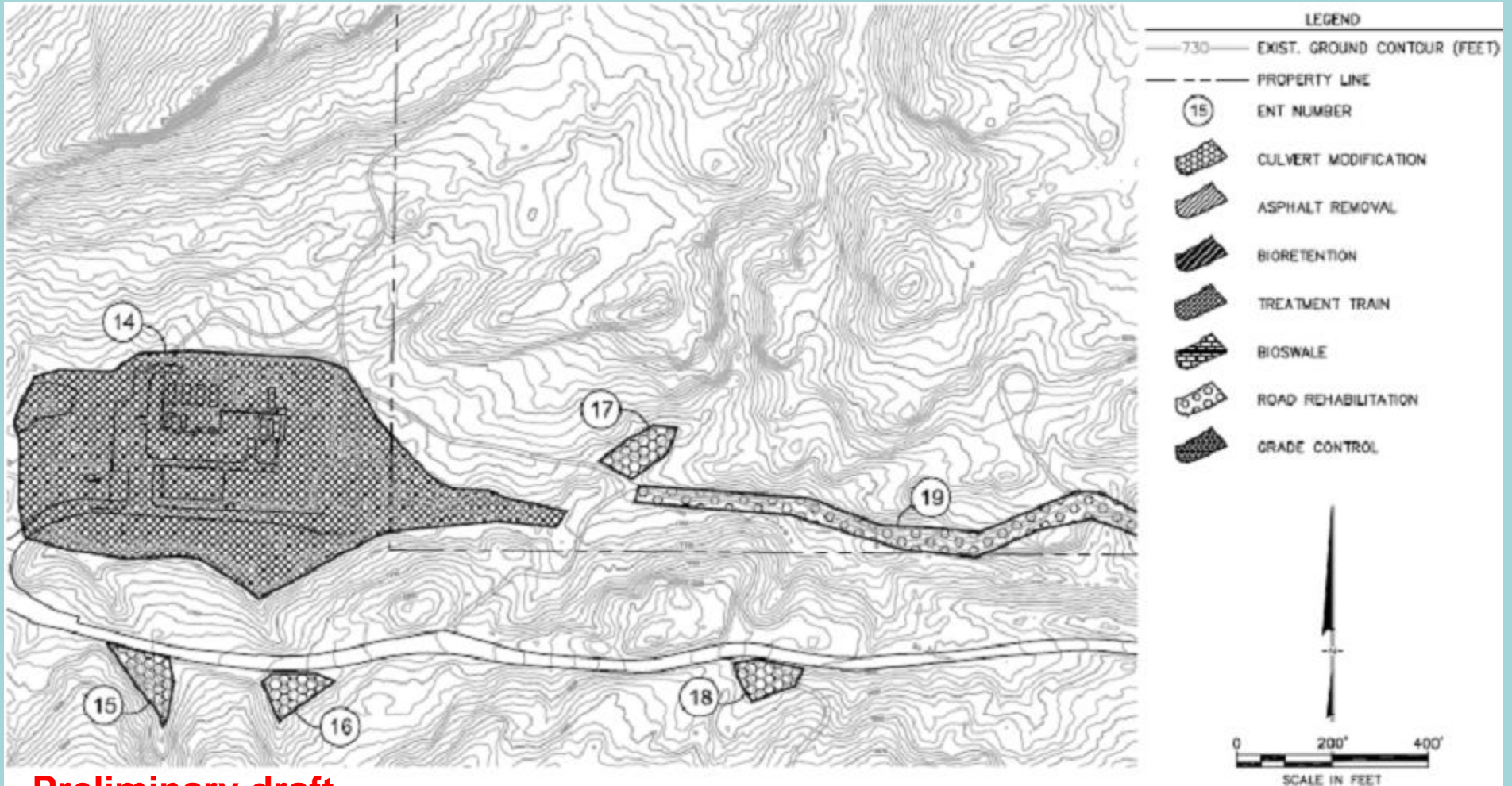

**Preliminary draft
Subject to change**

G4 – 009 East (Partial Sage Ranch Property)

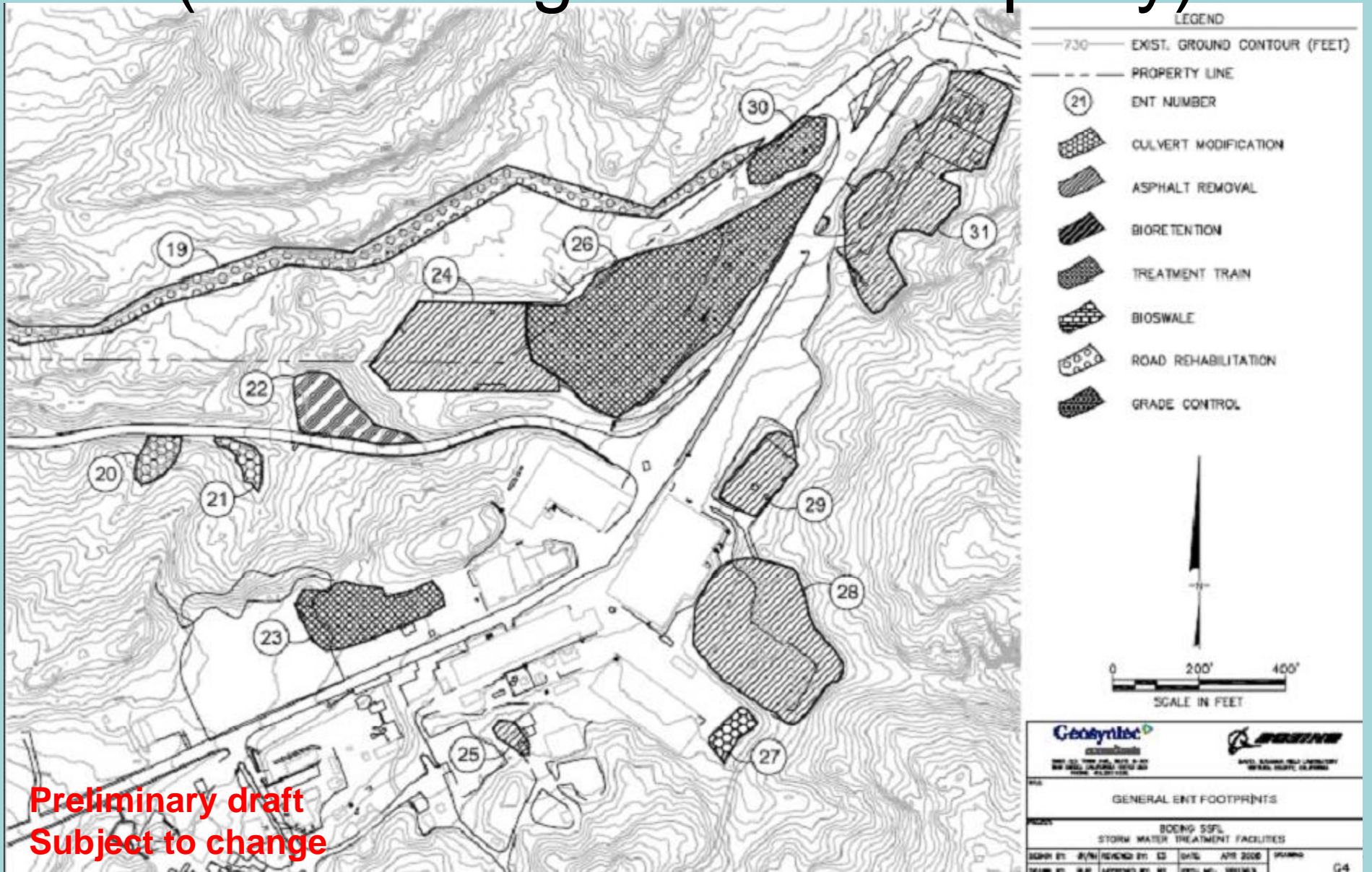

**Preliminary draft
Subject to change**

G5 – 008 Watershed

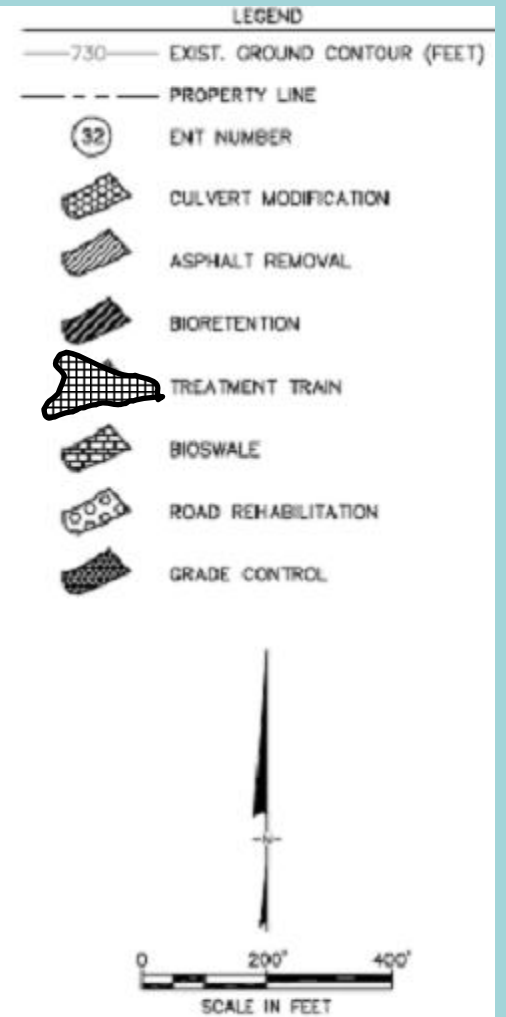
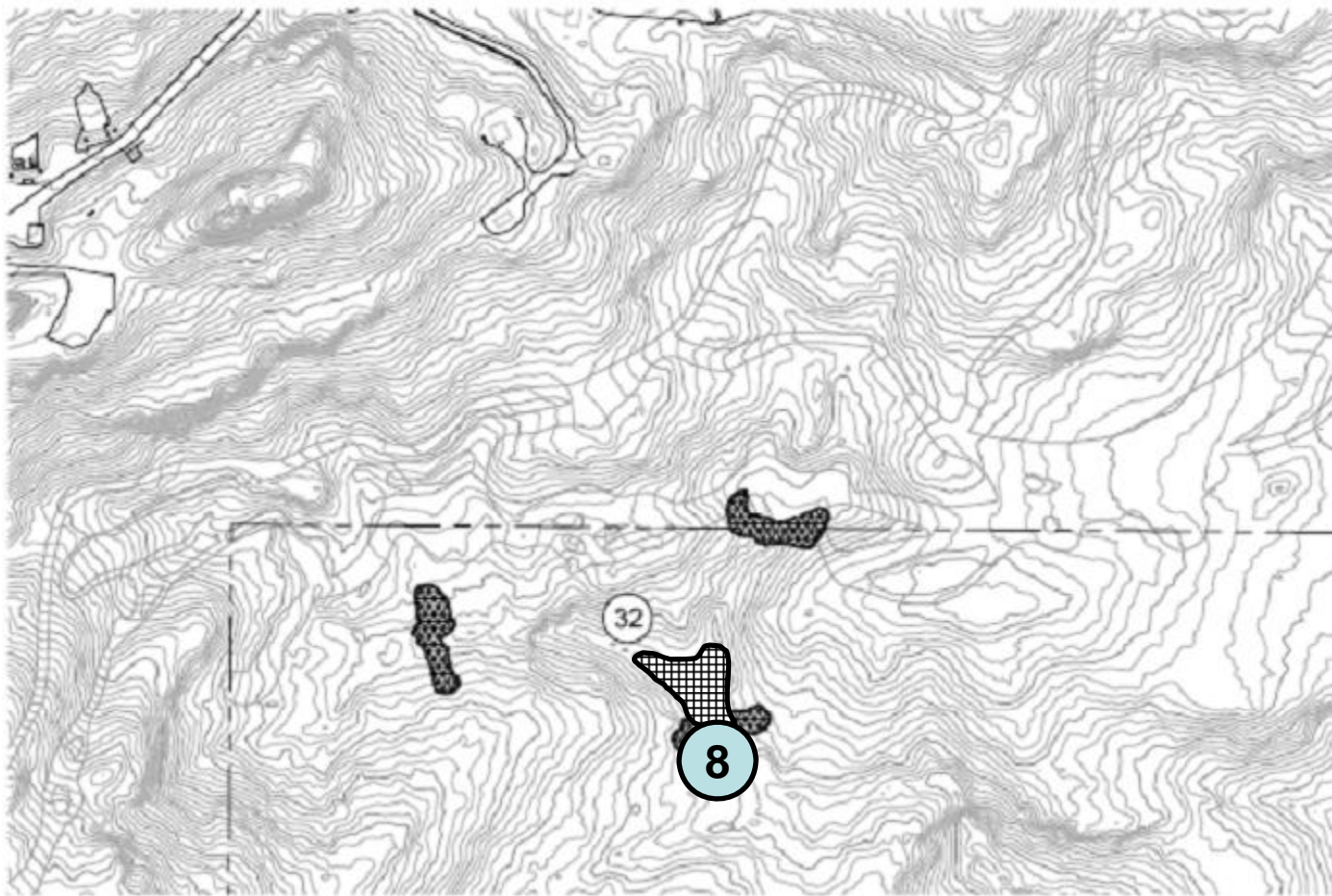

Preliminary draft
Subject to change

Asphalt Removal Detail

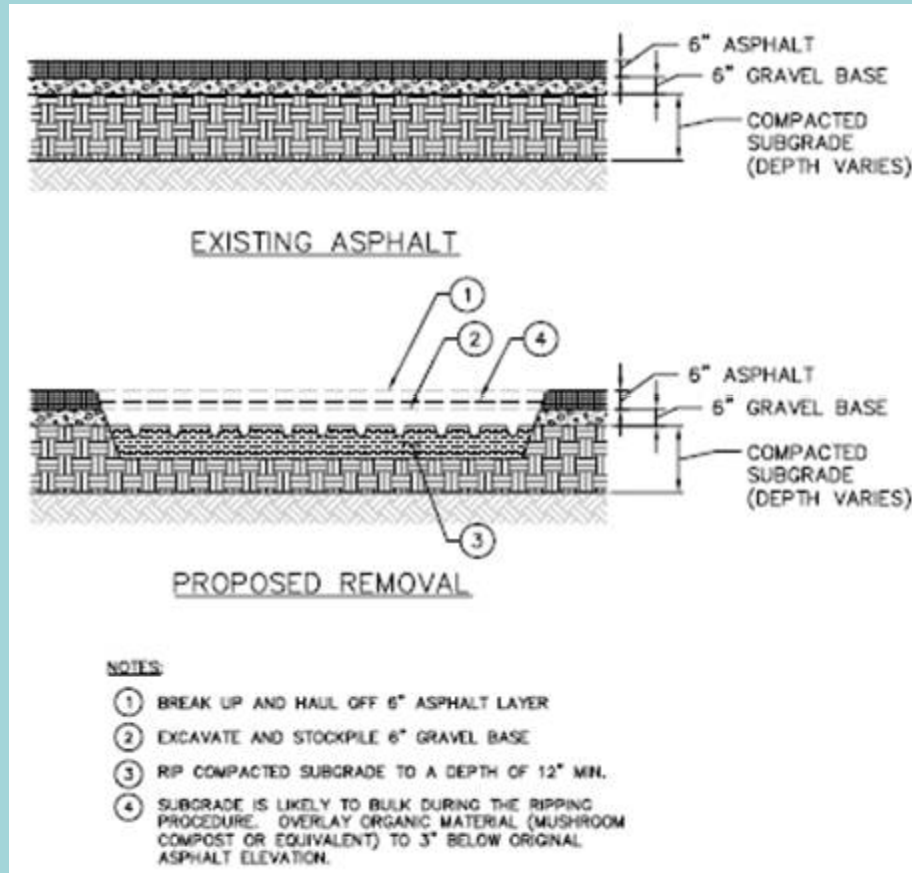

Incidental infiltration allowed

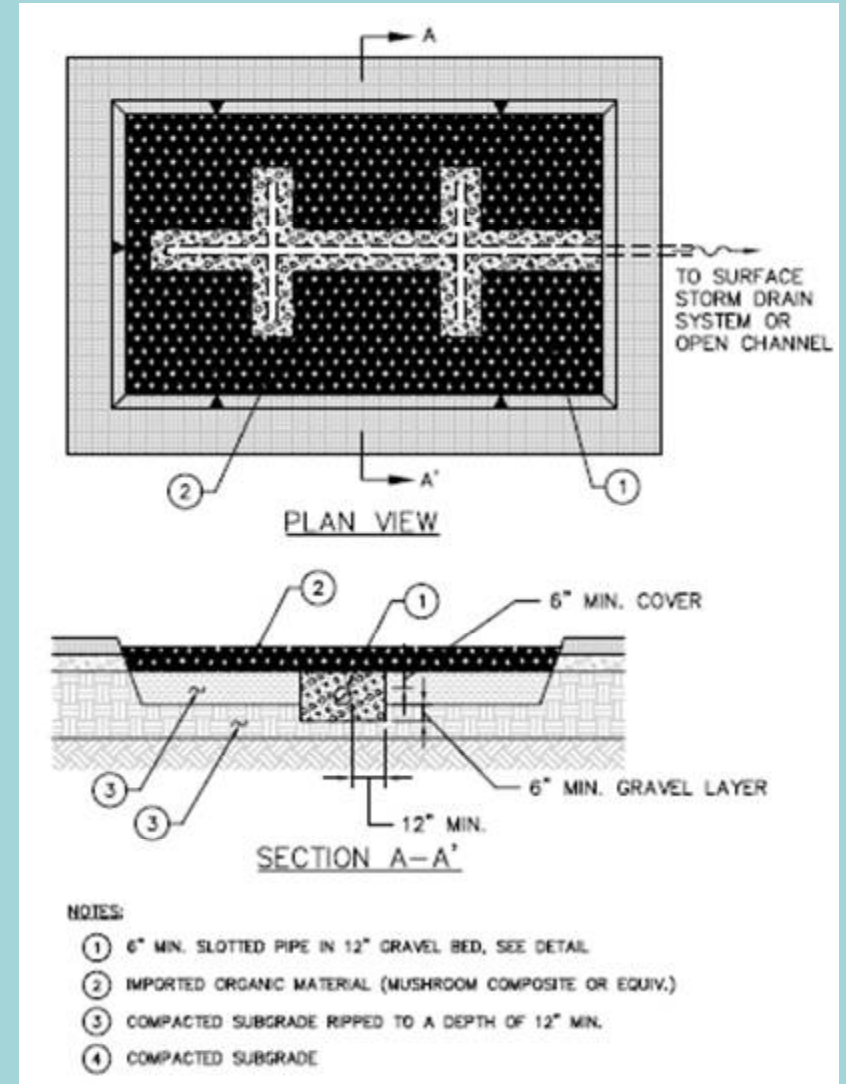

No infiltration allowed

Culvert Maintenance Detail

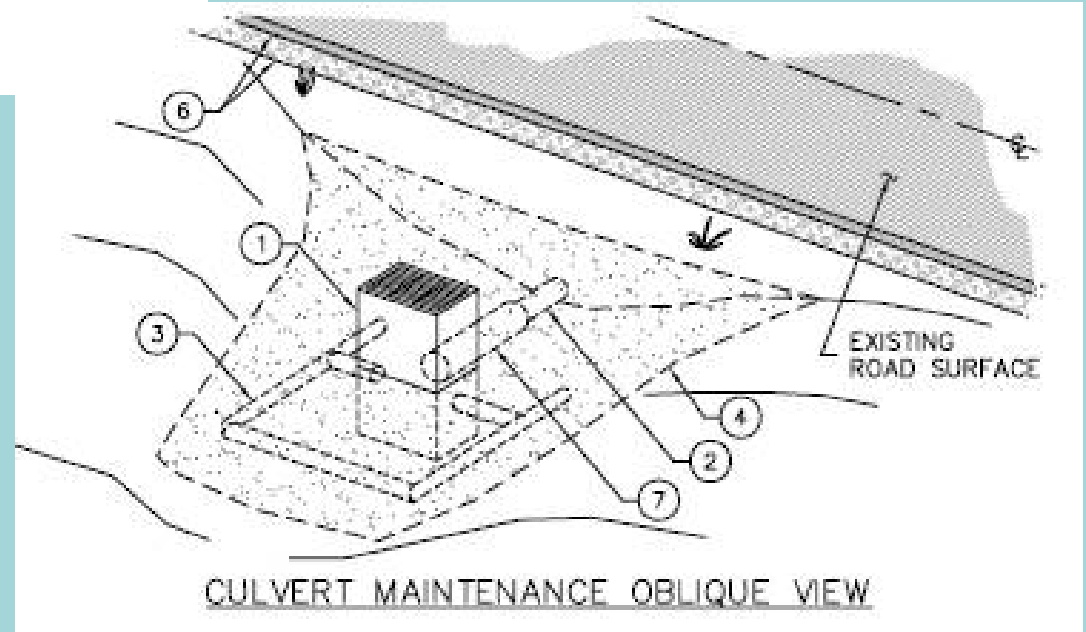
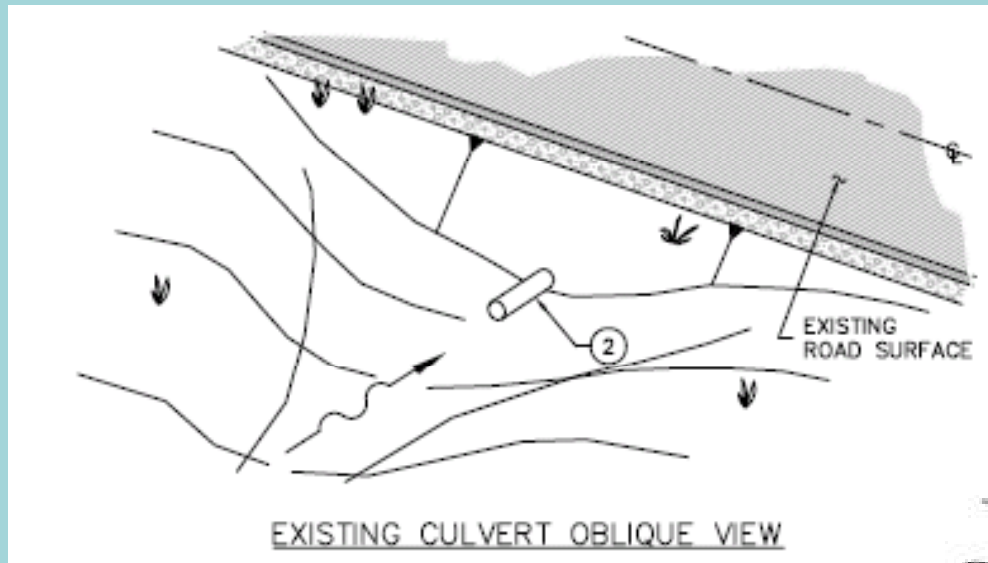

Culvert Maintenance Detail

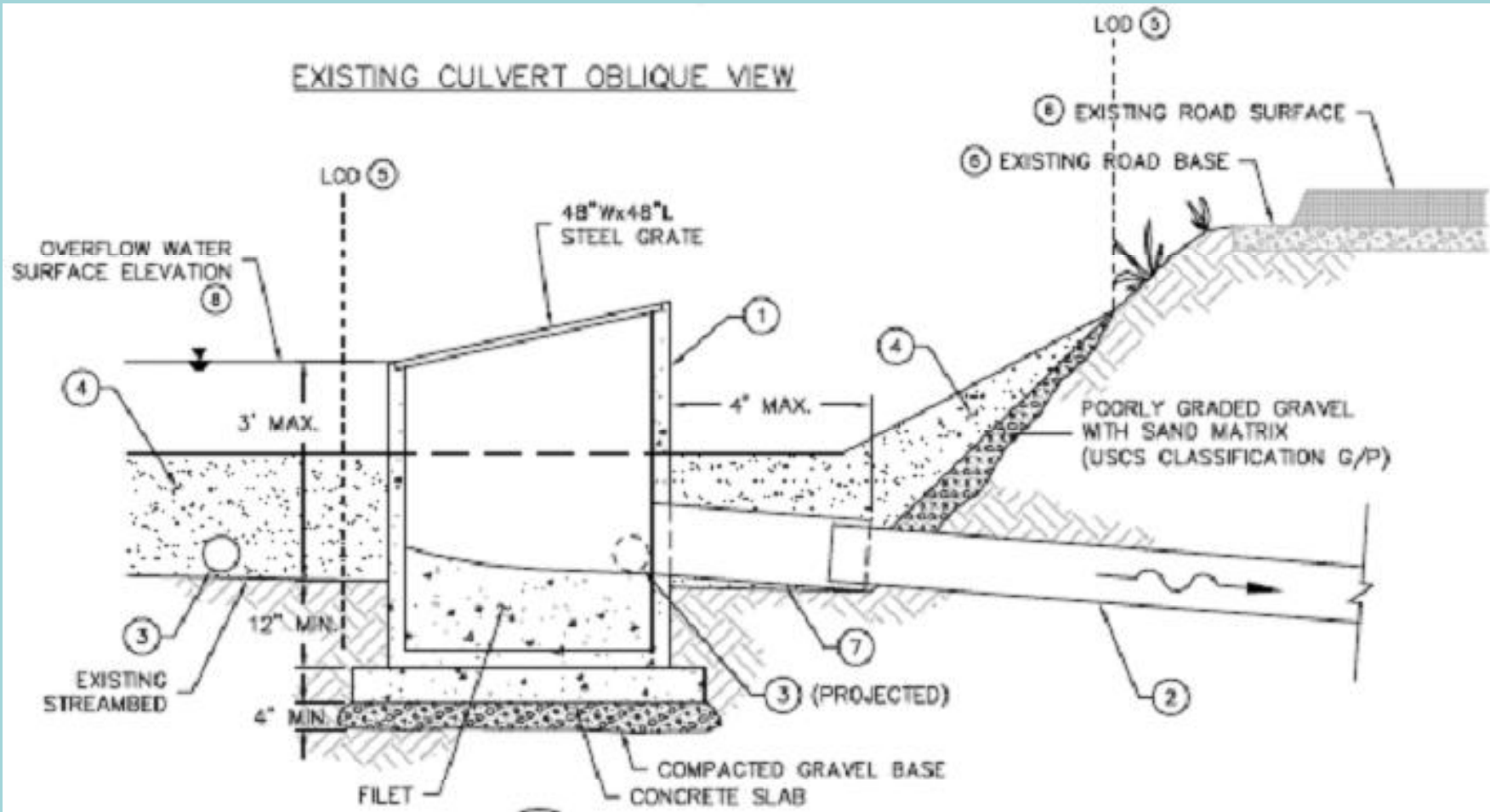

Sedimentation Basin Detail

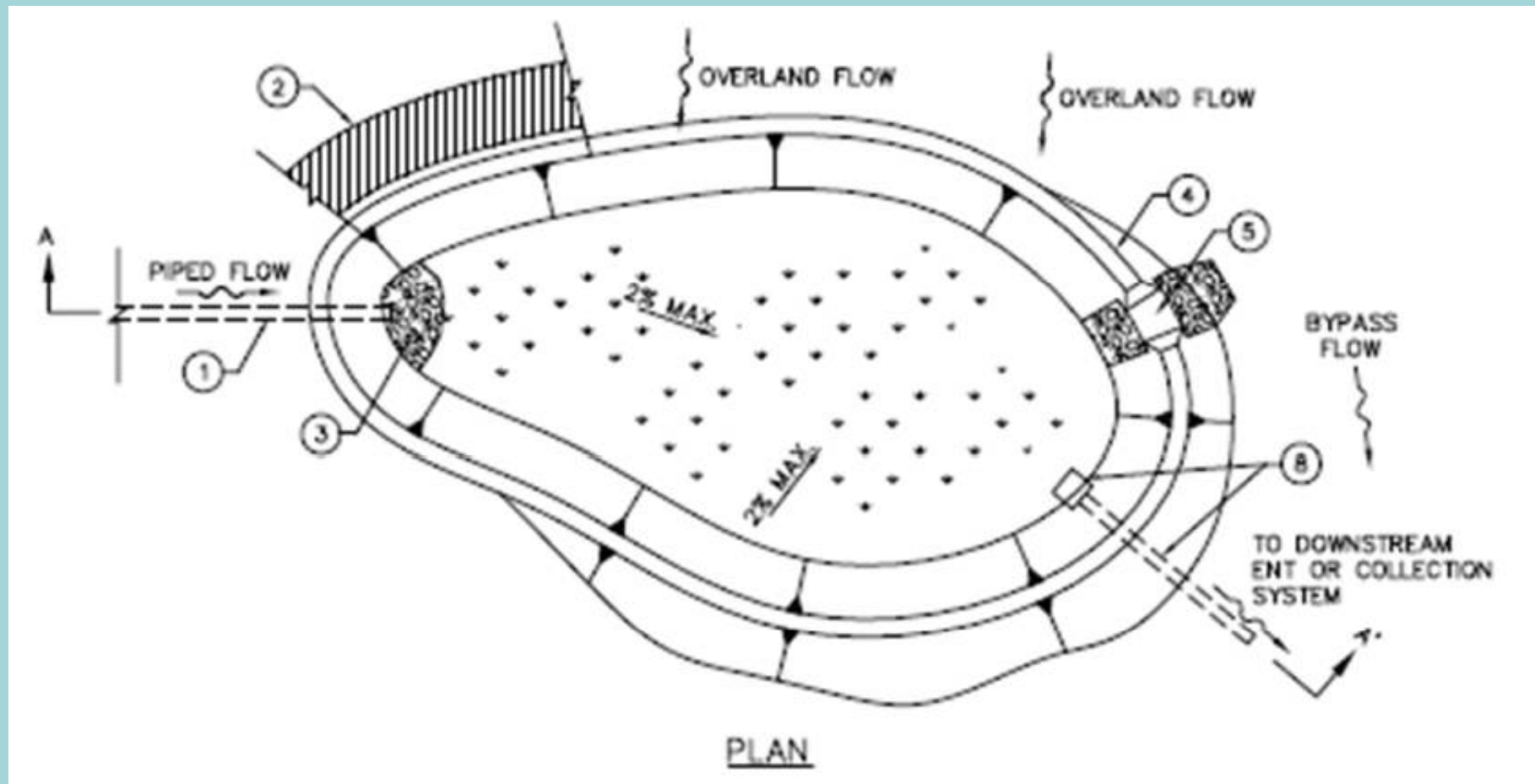

Sedimentation Basin Detail

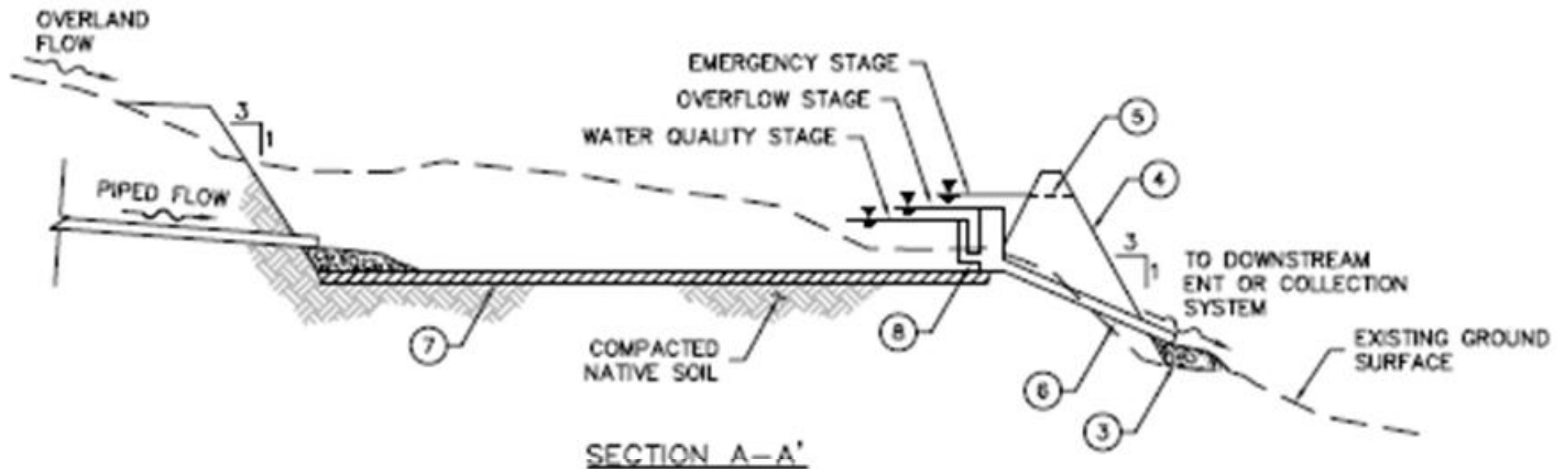

Bioretention Detail

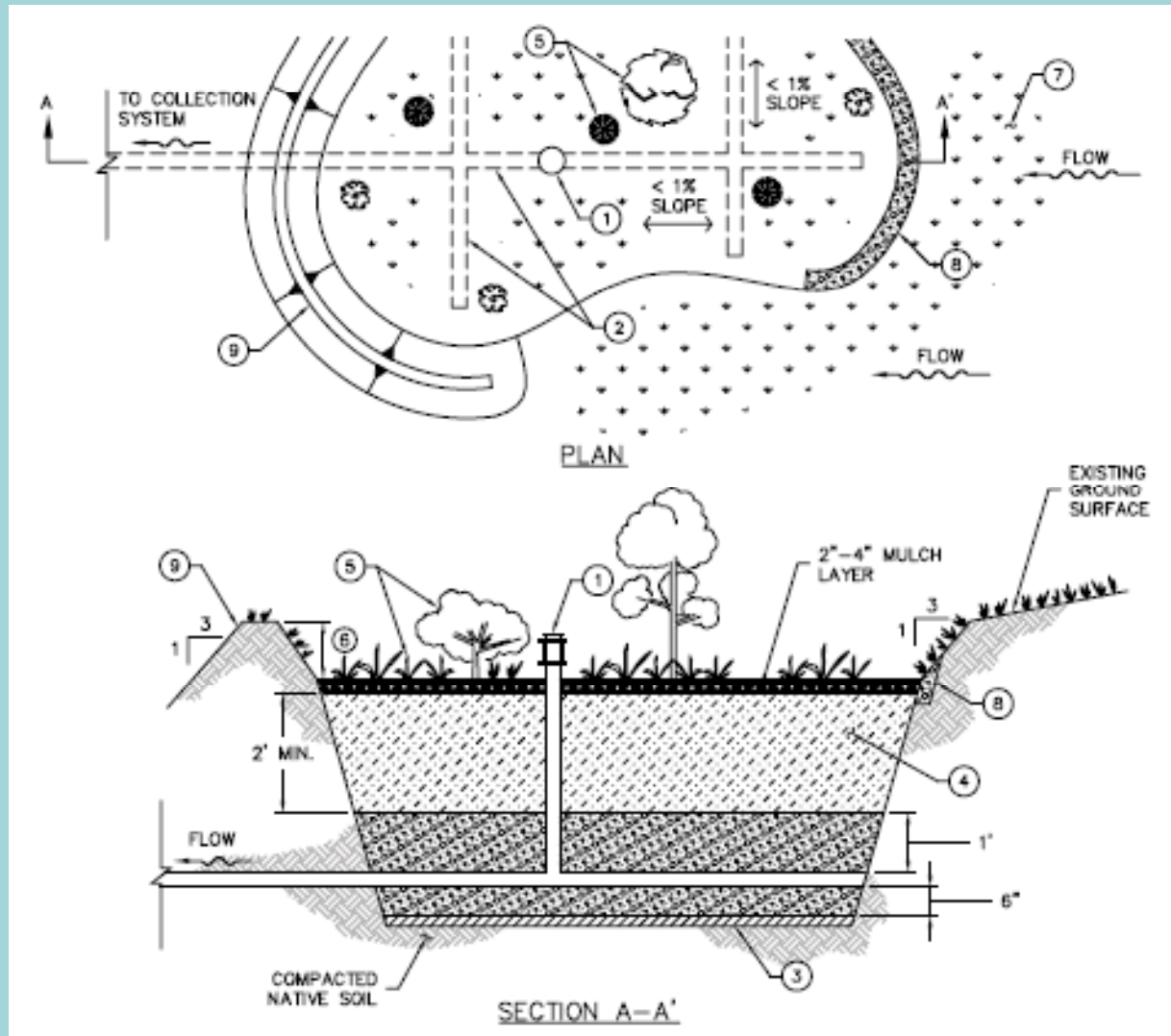

Draft LOX Concept

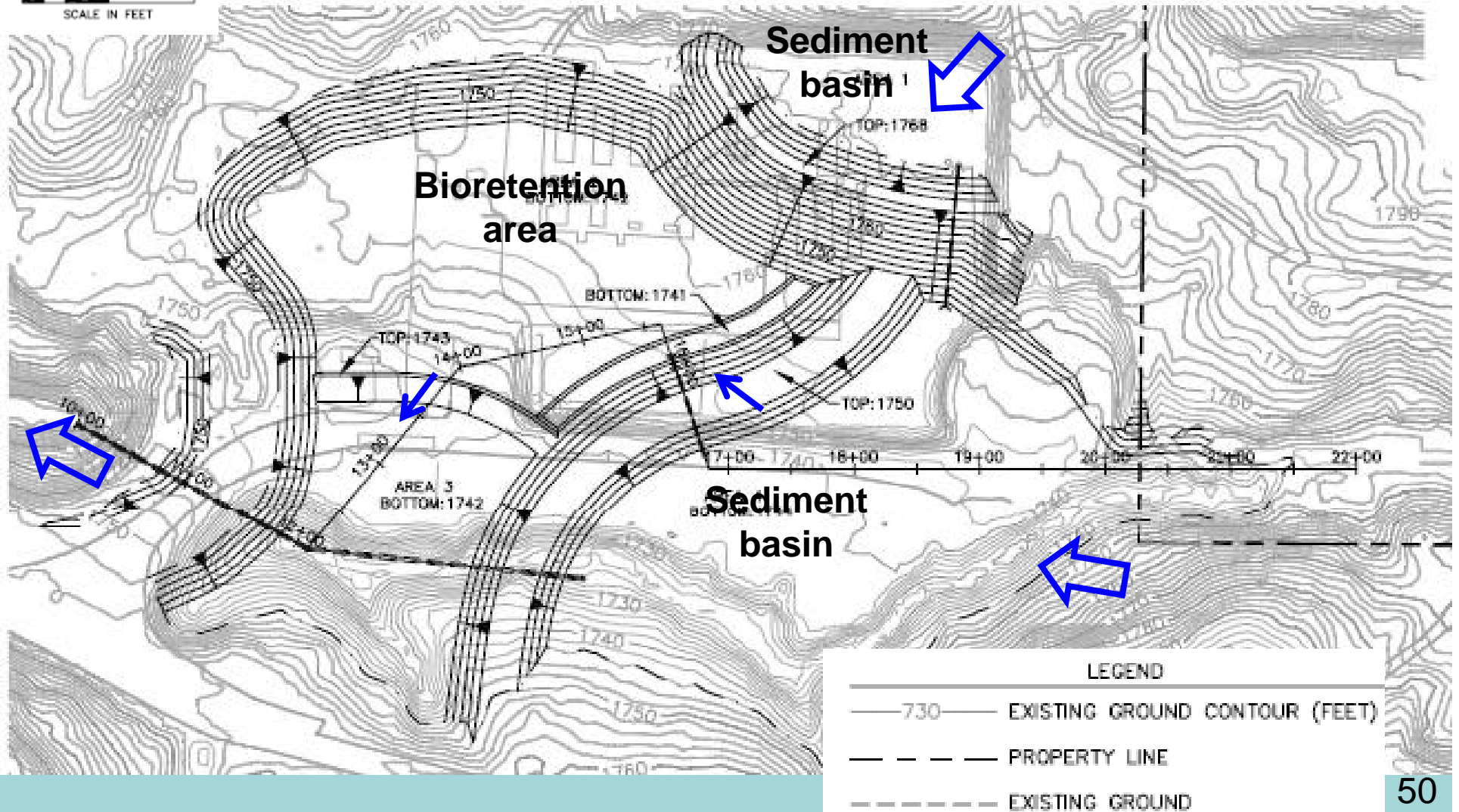
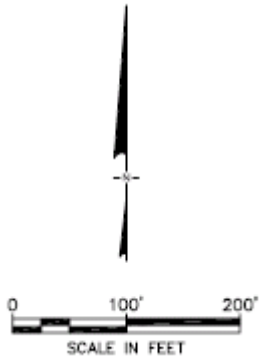

Preliminary Plan for ENTS Construction at or Near Cleanup Areas

- Some ENTS construction will be done in contaminated areas
- Construction will require:
 - Current sampling to satisfy data gaps
 - Additional sampling at time of construction
 - Removal of contaminated soils below and around ENTS footprints
 - Avoiding infiltration from ENTS to groundwater plumes
 - Avoiding interference with future vapor treatment plans

Existing soil characterization data -- Additional characterization has been proposed by panel to fill data gaps in areas of ENTS construction

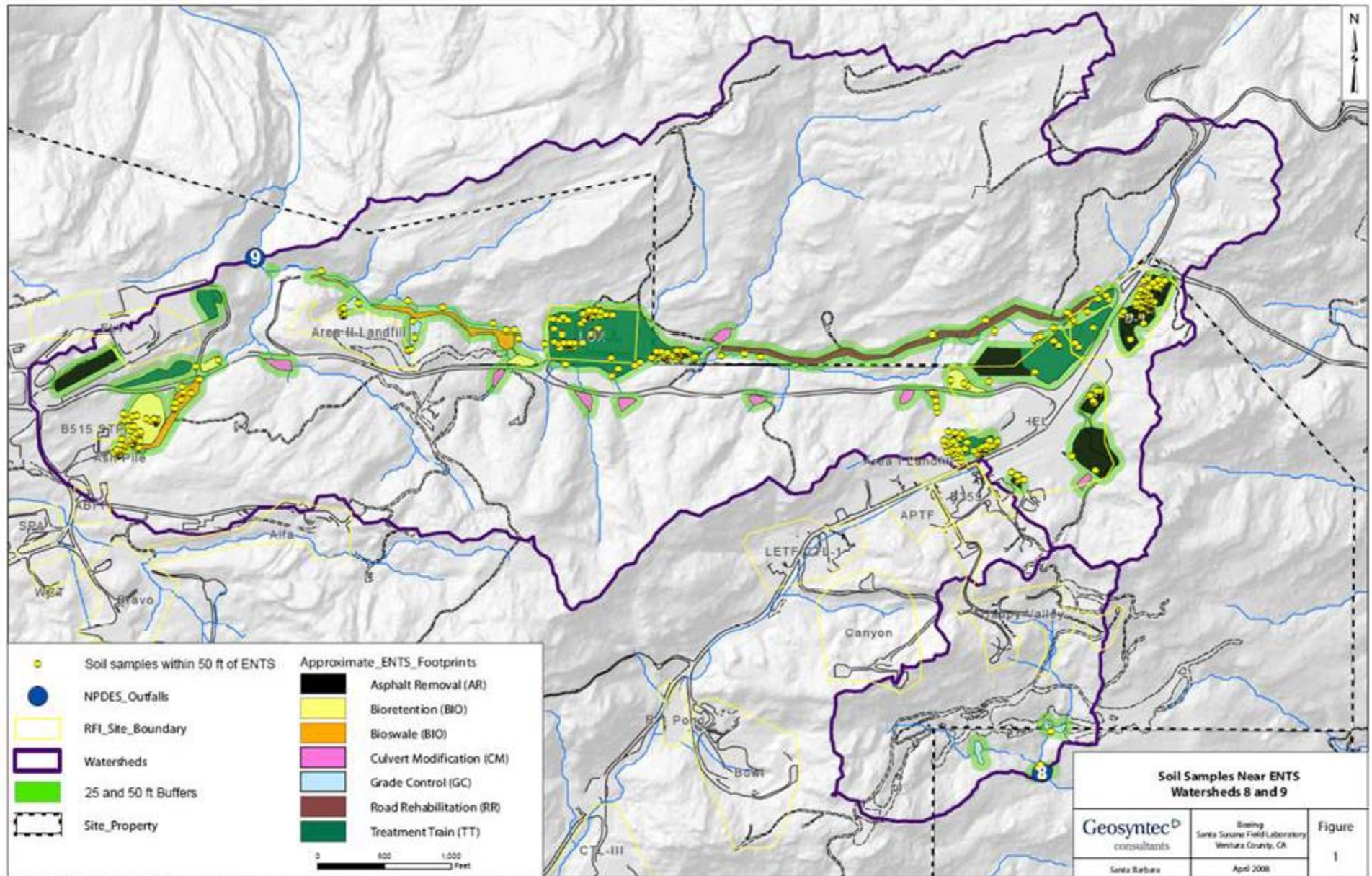

Public Recommendations to Panel

- ENTS recommendations received from CleanupRocketdyne.org approximately 3 weeks ago
- Expert Panel appreciates all input and is reviewing these recommendations
- General responses:
 - Additional ELV drainage being routed to helipad ENTS
 - Skyline, SPA, Alfa, Bravo RFI areas do not drain to outfall 009, but receive treatment at outfall 018
 - Proposed ENTS locations have been strategically located near or downstream of areas of historic activity or known surface soil contamination
 - Public recommendations in many cases are consistent with these strategic ENTS locations proposed by the Panel

Example Agency Coordination

Agency/Group	Action	Status
LARWQCB	Progress reports at Board hearings	Dr Stenstrom spoke at March & April hearings
	Permit reopener to incorporate design storm	Tentatively planned for Fall '08
	401 Certification	Pending
DTSC	Approval for ENTS construction plan	Initial comments received; held initial meeting to discuss preliminary approach for dealing with contamination around ENTS areas
Ventura County	CEQA lead agency; CUP modification & zoning clearance; grading permit; oak tree permits	Held initial meetings to discuss application/submittal process; developing application now
Santa Monica Mountains Conservancy	Approval for ENTS projects on Sage Ranch	Held initial meeting to discuss proposed plans
NASA/GSA	Approval for ENTS projects on NASA property	Held initial meetings to discuss proposed plans, submitted previous presentation slides
CDFG	Approval/SAA for ENTS projects in jurisdictional drainages	Held initial meeting & site visit April 10
ACOE	Jurisdictional Determination	Initial meeting planned

Questions on ENTS Conceptual Designs?

Meeting Agenda

- Pre-meeting Panel/Team/Public Informal Discussions
- Expert Panel
 - Panel members/scope/schedule
 - ENTS/design storm/site overview
- Public Meeting/Field Trip Recaps
- Respond to questions/comments from March public meeting
- Draft ENTS conceptual designs
 - Presented recommended ENTS conceptual designs
 - Discuss cleanuprocketdyne.org recommendations
- **Design Storm Recommendation**
- Wrap-up and Future Efforts

What is a Site-Specific Design Storm?

- Storm depth or rain intensity to use for assessing compliance and therefore driving selection and design/sizing of controls:
 - e.g. natural treatment systems for 008 and 009
 - Other treatment controls for other outfalls

Design Storm/ENTS

The Panel's Goal is a system of ENTS and other controls and a design storm that:

- Maximize the probability of attaining numeric effluent limits
- Minimize the potential impacts to downstream residents and the environment
- Protect the natural site conditions and is feasible given the site's constraints

Site Specific Design Storm Preliminary Recommendation

- The Panel recommends that the 1-year return interval storm event be used as the single site-wide design storm:
 - Either a 24-hour storm (2.5 inches) or
 - 0.6 inches per houras measured at an onsite rain gage
- About 95 percent of all storms would be smaller

Design Storm Volume Comparison

ENTS Volume (ac-ft) vs Design Storm (24-hr depth)

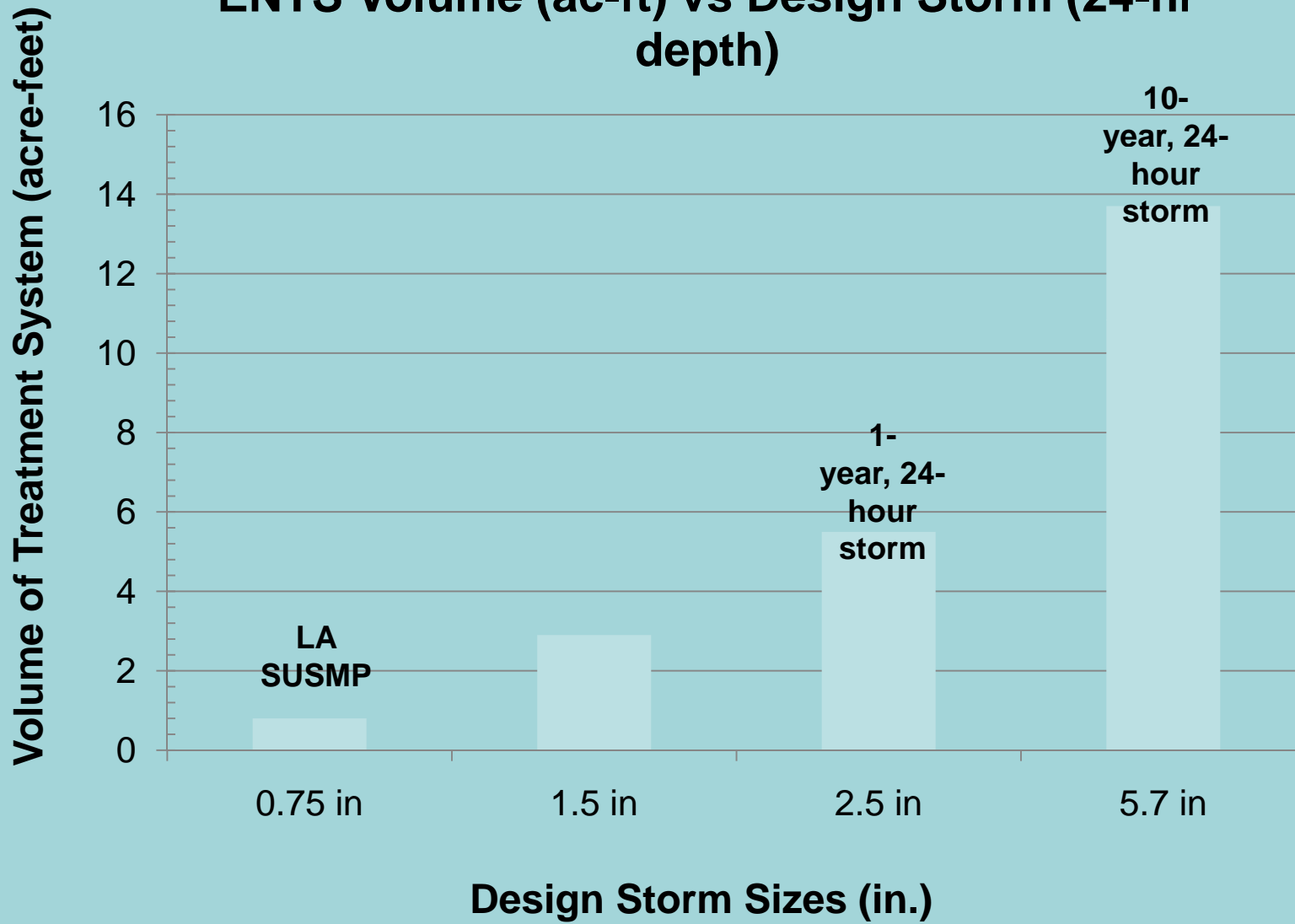

Percent of Storms Treated at SSFL Using 1-Year Design Storm

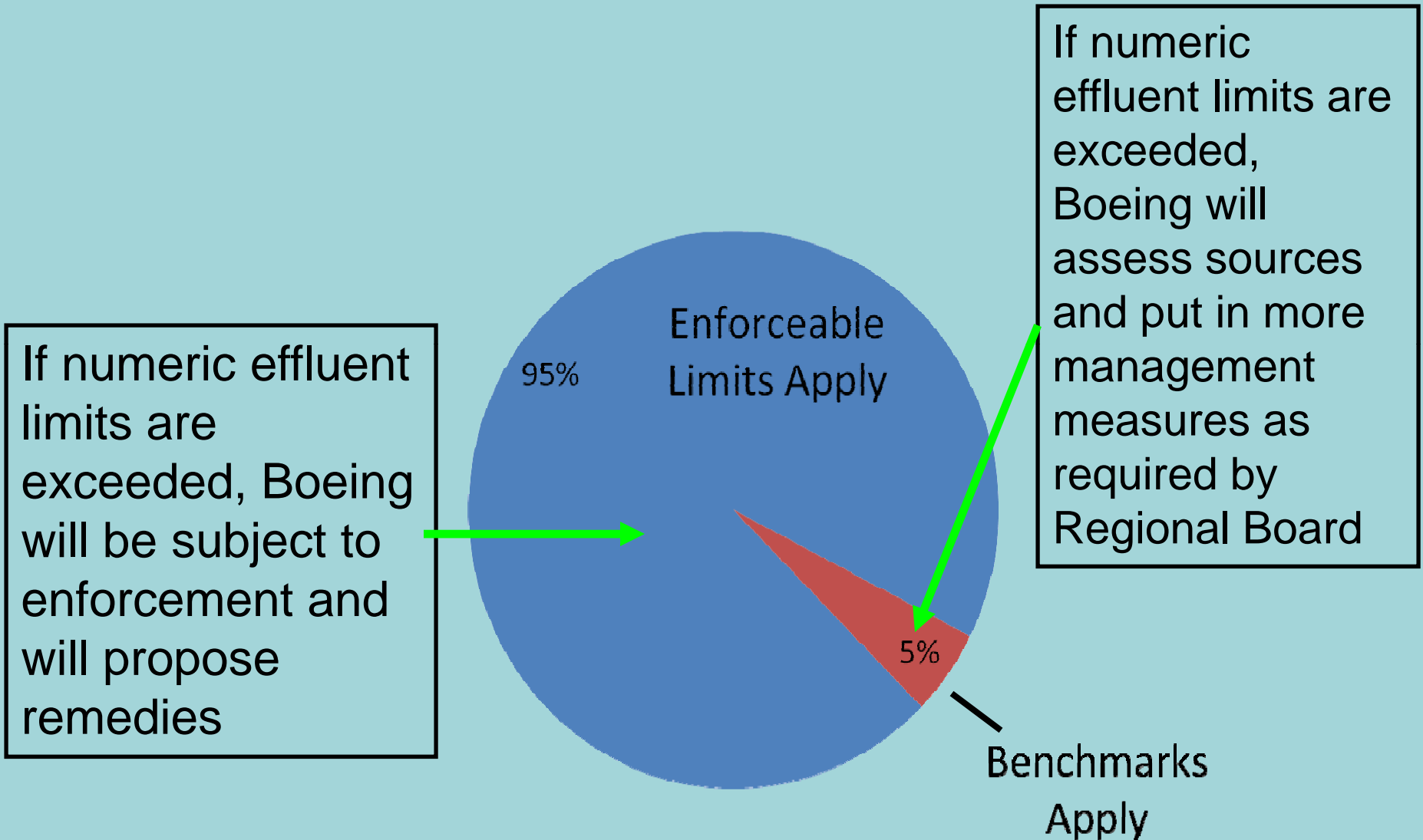

If numeric effluent limits are exceeded, Boeing will be subject to enforcement and will propose remedies

If numeric effluent limits are exceeded, Boeing will assess sources and put in more management measures as required by Regional Board

ENTS sizing curve for a hypothetical volume-based system implemented at outfall 008

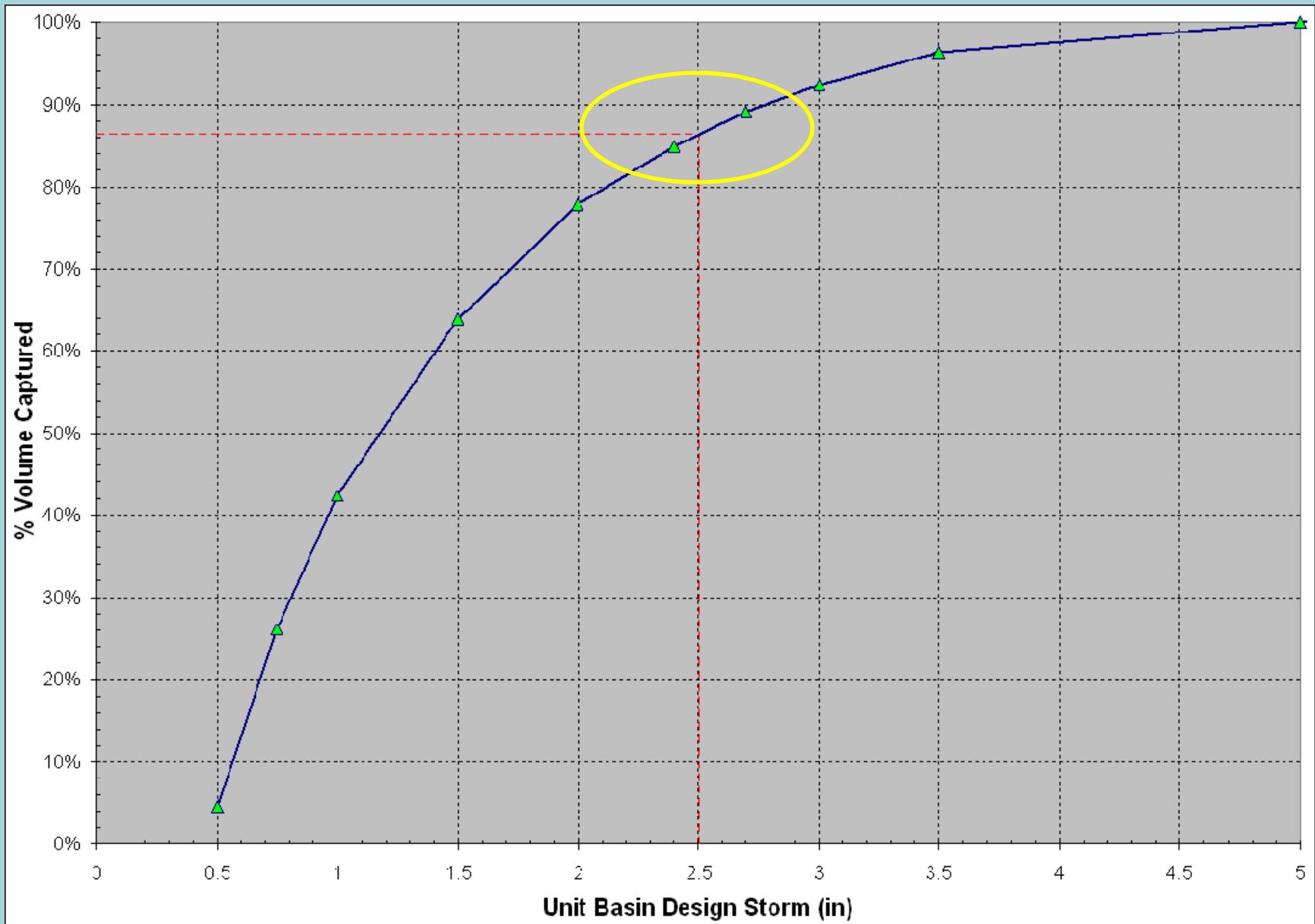

Questions Regarding Preliminary Design Storm Recommendation?

Panel Future Efforts

- Finalize Design Storm Recommendation
- Finalize conceptual ENTS designs
- Review preliminary & final ENTS designs
- Review ENTS operations and maintenance plan
- Review ENTS effectiveness & impact monitoring program:
 - Pollutant removal
 - Maintenance/cleanout triggers

THANK YOU FOR YOUR TIME

For questions or comments, contact:
Mark Schultheis, Geosyntec Consultants
800-293-4136
mschultheis@geosyntec.com