

717 SERIES

FLAMMABLE MATERIAL LOCATIONS

CAUTION: Rescue crews wearing full PPE to include SCBA's must use caution when moving across sections of aircraft that have been exposed to fatigue or fire as the result of an accident. Crews need to verify the integrity of the surface area before moving their weight and equipment across it. Signs could include but are not limited to deformity of structure, visual signs of flame impingement or uneven surfaces. Surface integrity can be checked with a pike pole, axe or any instrument used to sound surfaces for integrity.

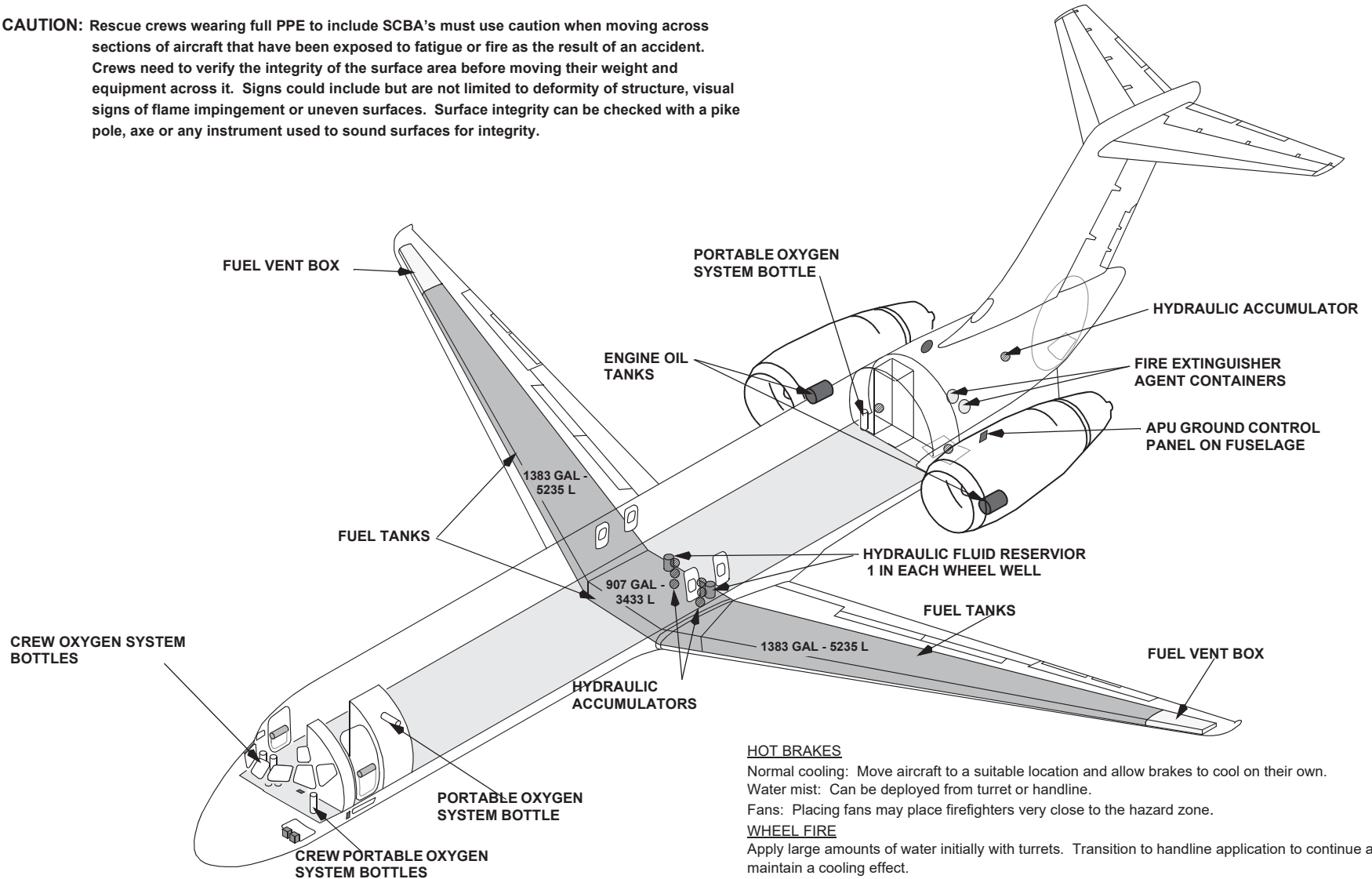

HOT BRAKES

Normal cooling: Move aircraft to a suitable location and allow brakes to cool on their own.
 Water mist: Can be deployed from turret or handline.

Fans: Placing fans may place firefighters very close to the hazard zone.

WHEEL FIRE

Apply large amounts of water initially with turrets. Transition to handline application to continue and maintain a cooling effect.

Wheels are equipped with fusible plugs designed to melt and deflate the tire when the temperature is excessive.

WARNING: Approach landing gear trucks from forward or aft at a 45 degree angle when approaching hot brakes or fighting a wheel fire, as rims and tires may pose a fragmentation hazard.

717 SERIES

EMERGENCY RESCUE ACCESS-1

1 PASSENGER AND SERVICE DOORS

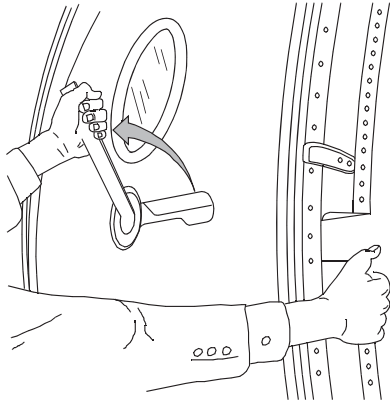

- TO OPEN DOOR:**
1. PULL HANDLE FROM RECESS.
 2. ROTATE HANDLE AFT.
 3. PULL DOOR OPEN.

2 OVERWING EMERGENCY EXITS



- TO OPEN DOOR:**
1. PUSH HANDLE RELEASE.
 2. PULL THE HANDLE AND, AT THE SAME TIME, PUSH IN TOP OF DOOR FORCIBLY.

3 TAIL CONE JETTISON LATCH

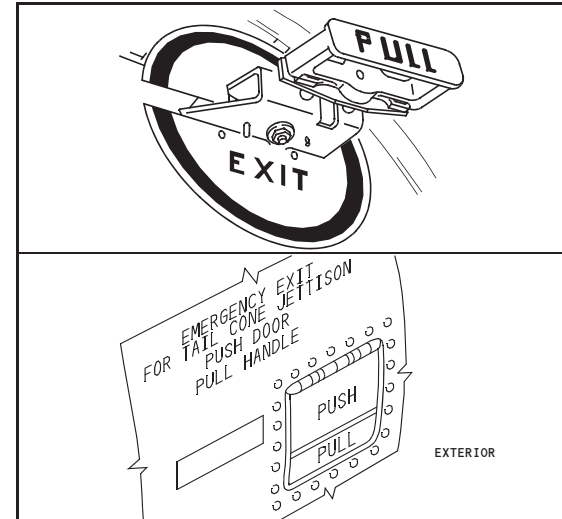

4 CUT-IN AREAS

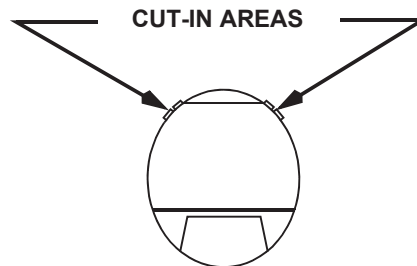

NOTE: CUT-IN AREAS REQUIRE METAL CUTTING PORTABLE POWER EQUIPMENT. BECAUSE OF TYPE OF STRUCTURE AND POSSIBLE INJURY TO PERSONNEL WITHIN, IT IS RECOMMENDED THAT MAJOR EFFORT TO GAIN ACCESS BE DIRECTED TO HATCHES AND DOORS. URGENCY OF SITUATION WILL DICTATE THE NECESSITY FOR A CUT-IN.

717 SERIES

EMERGENCY RESCUE ACCESS-2

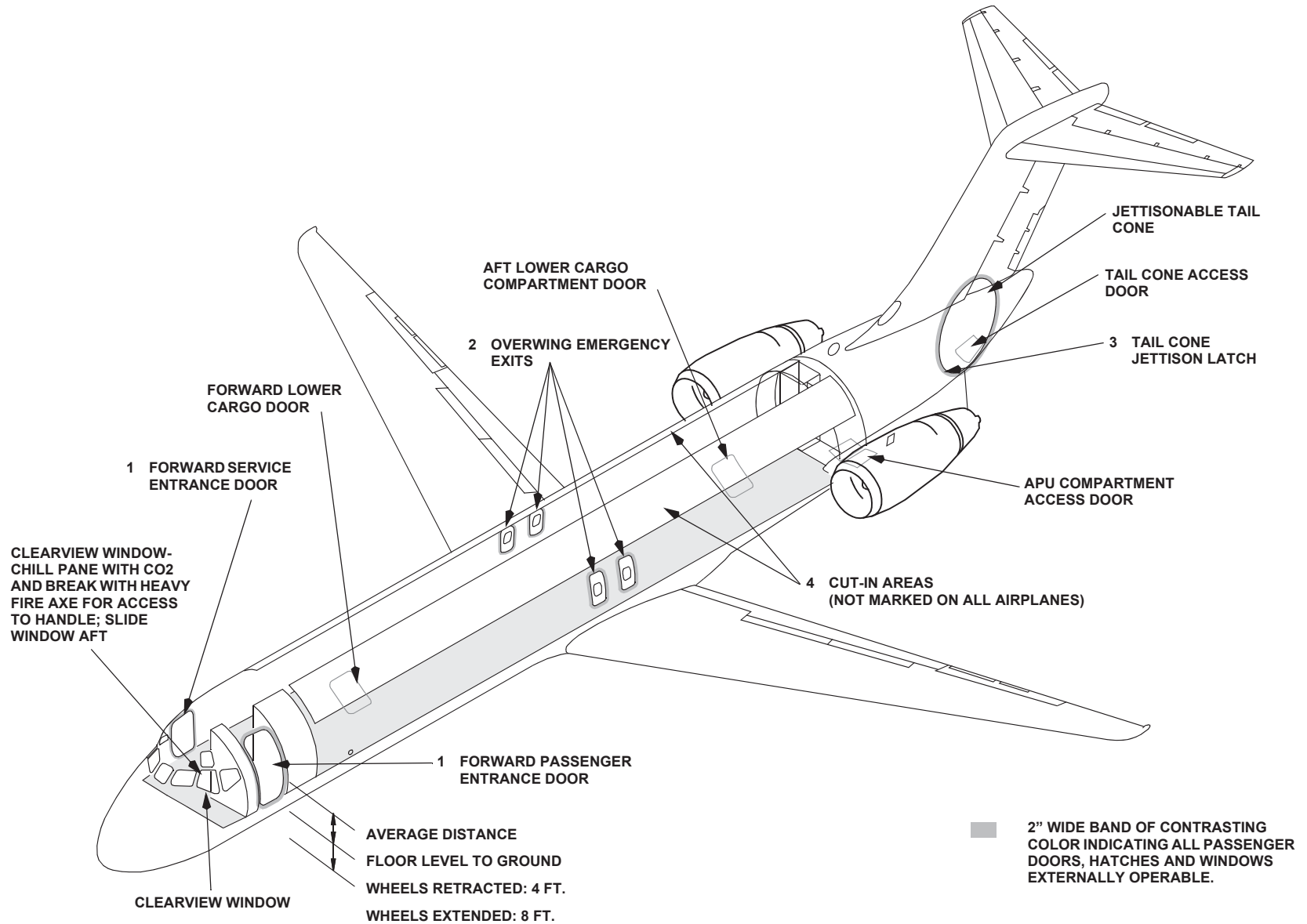

Copyright © Boeing. See title page for details.

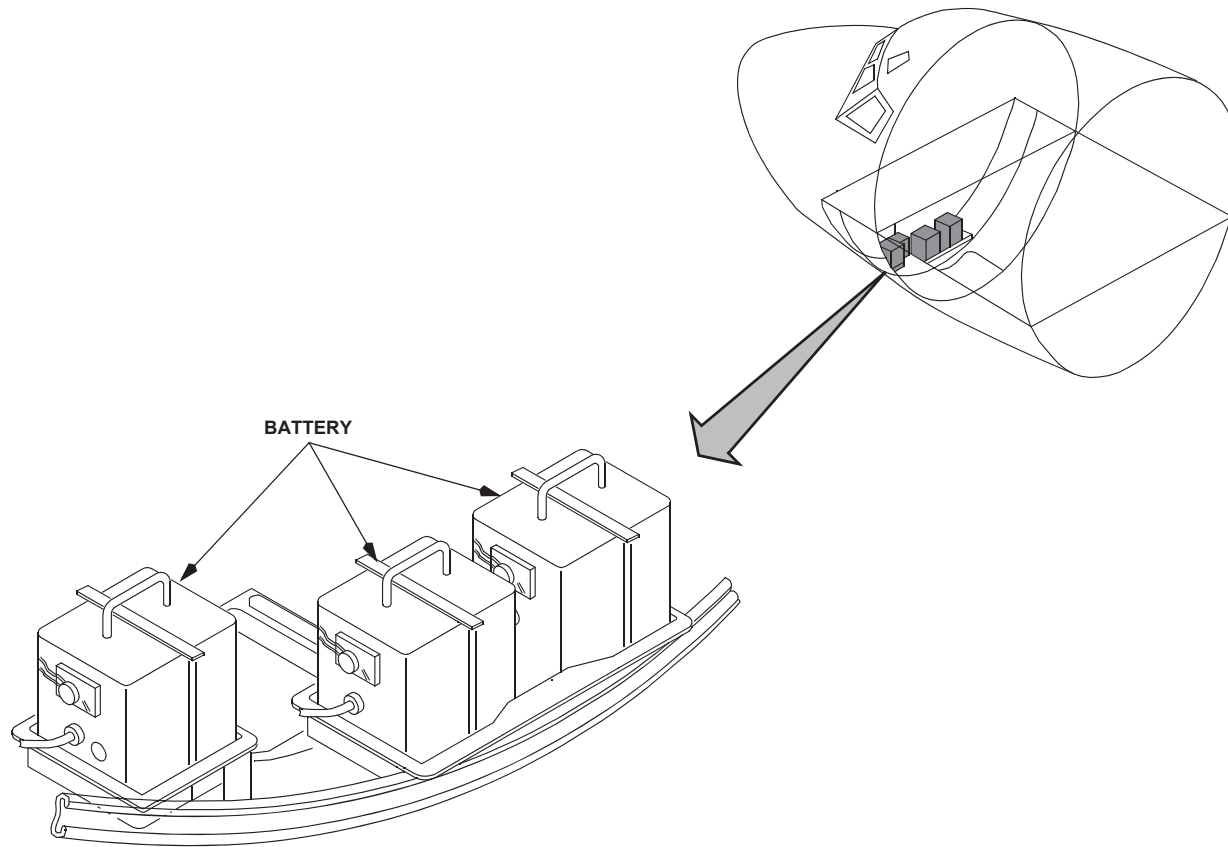

717 SERIES

FLIGHT DECK CONTROL SWITCH LOCATIONS

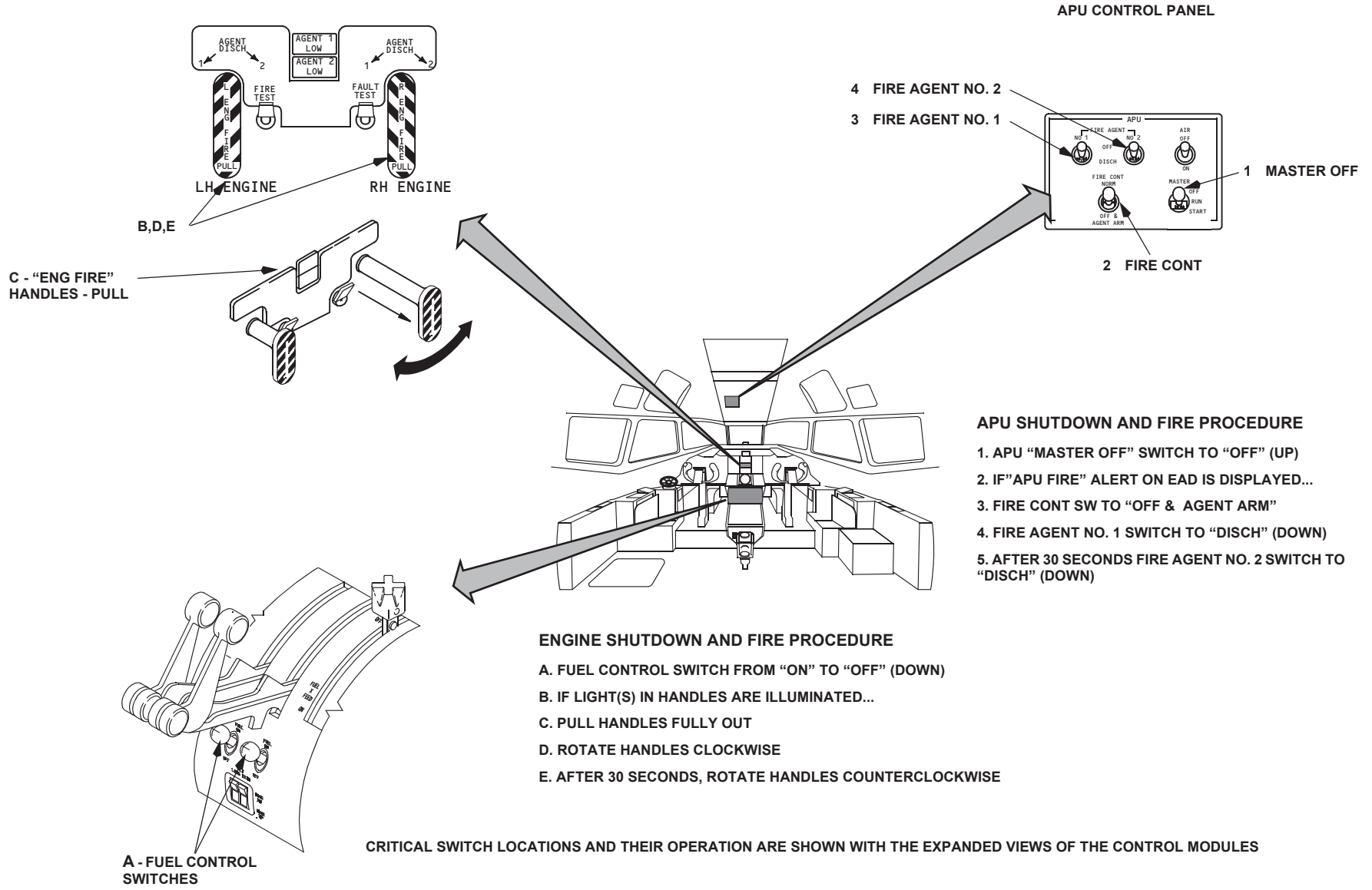

APU SHUTDOWN AND FIRE PROCEDURE

1. APU "MASTER OFF" SWITCH TO "OFF" (UP)
2. IF "APU FIRE" ALERT ON EAD IS DISPLAYED...
3. FIRE CONT SW TO "OFF & AGENT ARM"
4. FIRE AGENT NO. 1 SWITCH TO "DISCH" (DOWN)
5. AFTER 30 SECONDS FIRE AGENT NO. 2 SWITCH TO "DISCH" (DOWN)

ENGINE SHUTDOWN AND FIRE PROCEDURE

- A. FUEL CONTROL SWITCH FROM "ON" TO "OFF" (DOWN)
- B. IF LIGHT(S) IN HANDLES ARE ILLUMINATED...
- C. PULL HANDLES FULLY OUT
- D. ROTATE HANDLES CLOCKWISE
- E. AFTER 30 SECONDS, ROTATE HANDLES COUNTERCLOCKWISE

CRITICAL SWITCH LOCATIONS AND THEIR OPERATION ARE SHOWN WITH THE EXPANDED VIEWS OF THE CONTROL MODULES

Copyright © Boeing. See title page for details.

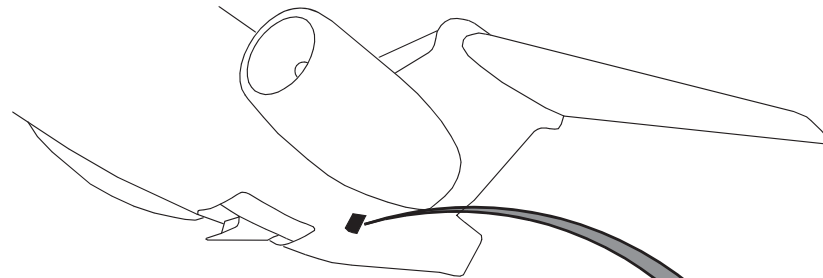

2 FIRE LIGHT

APU SHUTDOWN AND FIRE PROCEDURE

1. "APU SHUT OFF" SWITCH TO "SHUT OFF" (UP)
2. IF "FIRE" LIGHT IS ILLUMINATED...
3. FIRE AGENT 1 SWITCH TO "DISCHARGE" (UP)
4. AFTER 30 SECONDS, FIRE AGENT NO 2 SWITCH TO "DISCHARGE" (UP)

1 APU SHUT OFF SWITCH

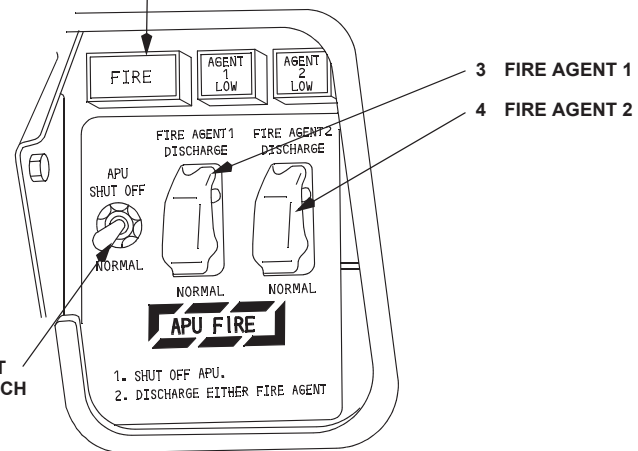

3 FIRE AGENT 1

4 FIRE AGENT 2

717 SERIES

COMPOSITE MATERIALS LOCATIONS

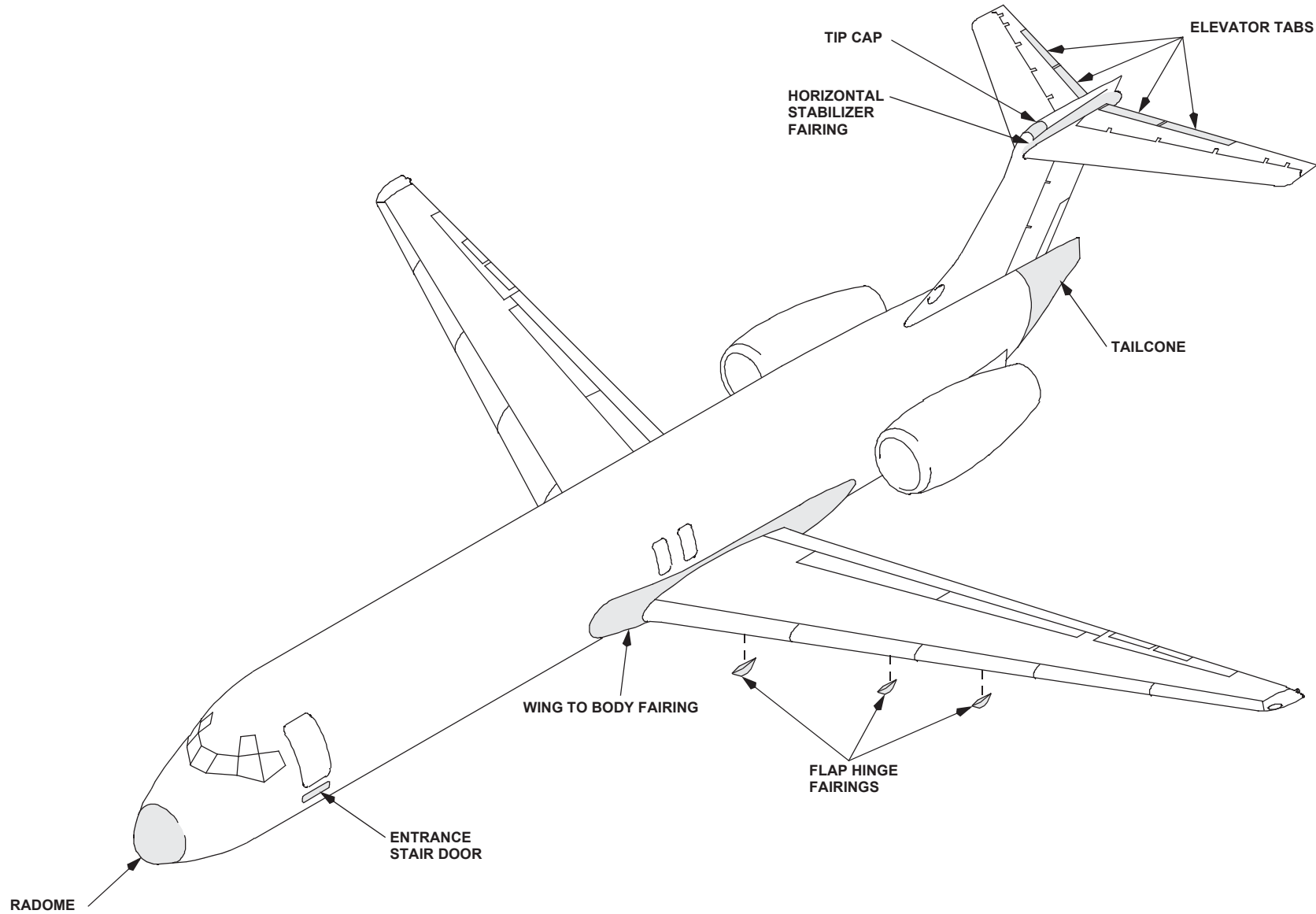



717 SERIES

Intentionally Blank