

# 720 & 720B SERIES

# FLAMMABLE MATERIAL LOCATIONS

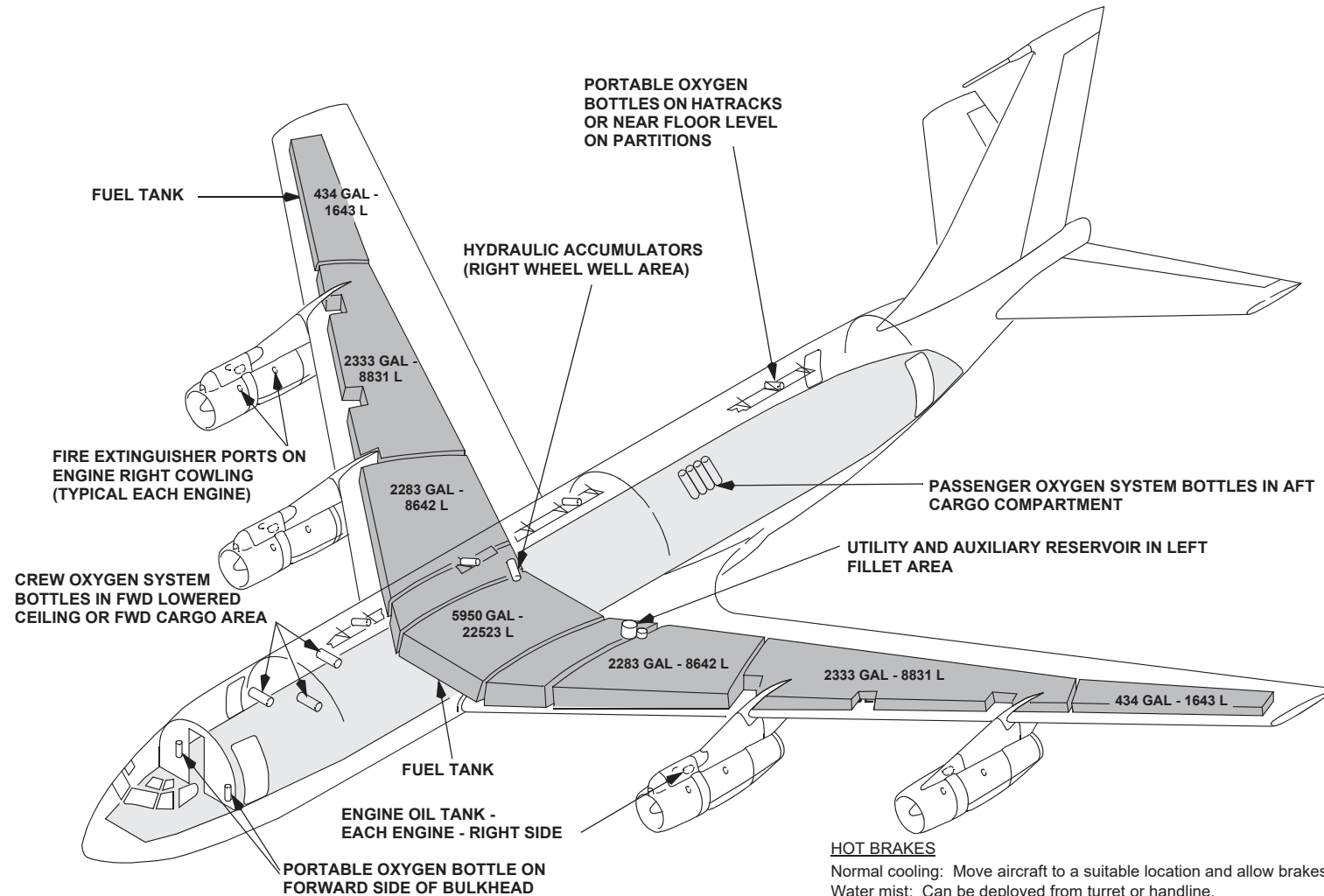

**CAUTION:** Rescue crews wearing full PPE to include SCBA's must use caution when moving across sections of aircraft that have been exposed to fatigue or fire as the result of an accident. Crews need to verify the integrity of the surface area before moving their weight and equipment across it. Signs could include but are not limited to deformity of structure, visual signs of flame impingement or uneven surfaces. Surface integrity can be checked with a pike pole, axe or any instrument used to sound surfaces for integrity.

**HOT BRAKES**  
 Normal cooling: Move aircraft to a suitable location and allow brakes to cool on their own.  
 Water mist: Can be deployed from turret or handline.  
 Fans: Placing fans may place firefighters very close to the hazard zone.

**WHEEL FIRE**  
 Apply large amounts of water initially with turrets. Transition to handline application to continue and maintain a cooling effect.  
 Wheels are equipped with fusible plugs designed to melt and deflate the tire when the temperature is excessive.

**WARNING:** Approach landing gear trucks from forward or aft at a 45 degree angle when approaching hot brakes or fighting a wheel fire, as rims and tires may pose a fragmentation hazard.

# 720 & 720B SERIES

# EMERGENCY RESCUE ACCESS-1

## 1 ENTRY DOOR EXTERNAL HANDLE

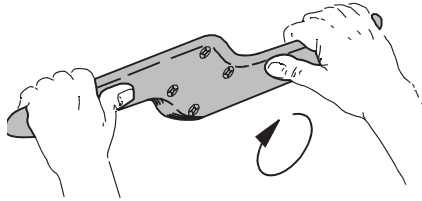

- TO OPEN DOOR:
1. PULL HANDLE OUTWARD.
  2. ROTATE CLOCKWISE.
  3. PULL DOOR OUTWARD.

## 2 GALLEY DOOR EXTERNAL HANDLE

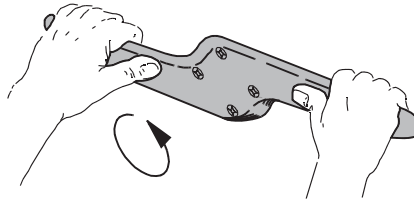

- TO OPEN DOOR:
1. PULL HANDLE OUTWARD.
  2. ROTATE COUNTERCLOCKWISE.
  3. PULL DOOR OUTWARD.

## 3 EMERGENCY OVERWING EXIT HATCHES PUSH PANEL

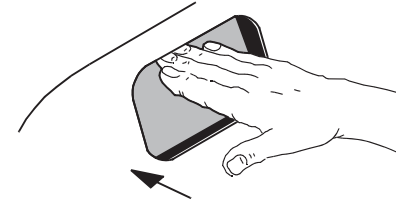

- TO OPEN HATCH:
1. PUSH IN PANEL.
  2. PUSH HATCH INWARD.

WARNING: PASSENGER AND SERVICE DOORS, SLIDE MAY AUTOMATICALLY DEPLOY WHEN DOORS ARE OPENED FROM OUTSIDE.

## 4 CUT-IN AREAS

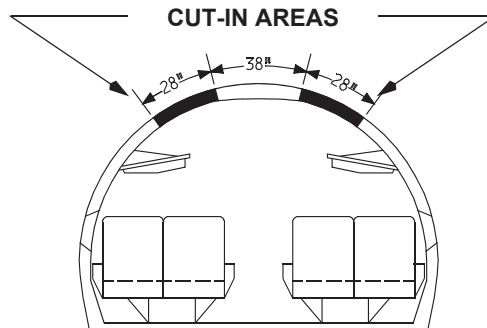

NOTE: CUT-IN AREAS REQUIRE METAL CUTTING PORTABLE POWER EQUIPMENT. BECAUSE OF TYPE OF STRUCTURE AND POSSIBLE INJURY TO PERSONNEL WITHIN, IT IS RECOMMENDED THAT MAJOR EFFORT TO GAIN ACCESS BE DIRECTED TO HATCHES AND DOORS. URGENCY OF SITUATION WILL DICTATE THE NECESSITY FOR A CUT-IN.

# 720 & 720B SERIES

# EMERGENCY RESCUE ACCESS-2

■ 2" WIDE BAND OF CONTRASTING COLOR INDICATING ALL PASSENGER DOORS, HATCHES AND WINDOWS EXTERNALLY OPERABLE.

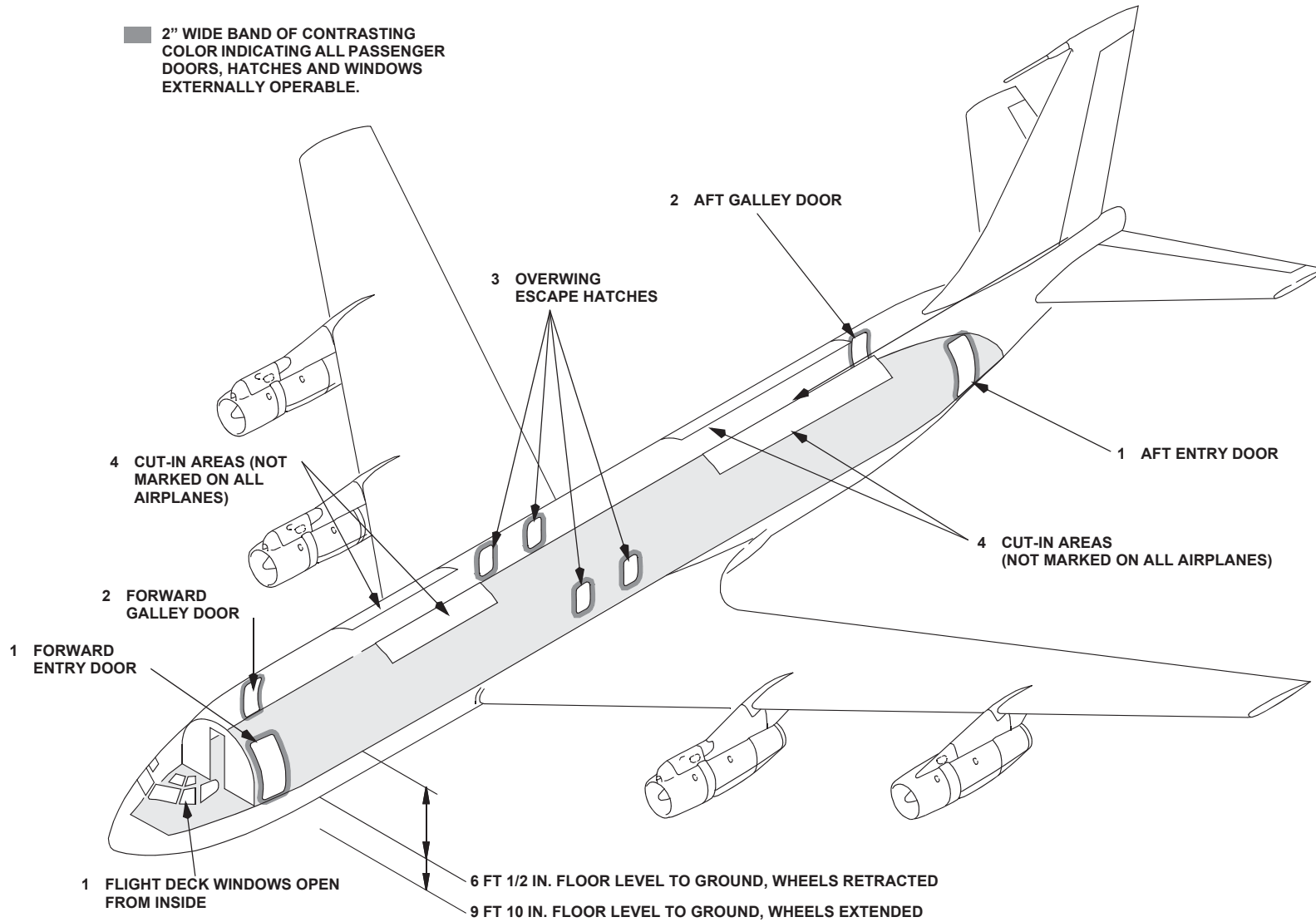

**720 & 720B SERIES**

**BATTERY LOCATIONS**

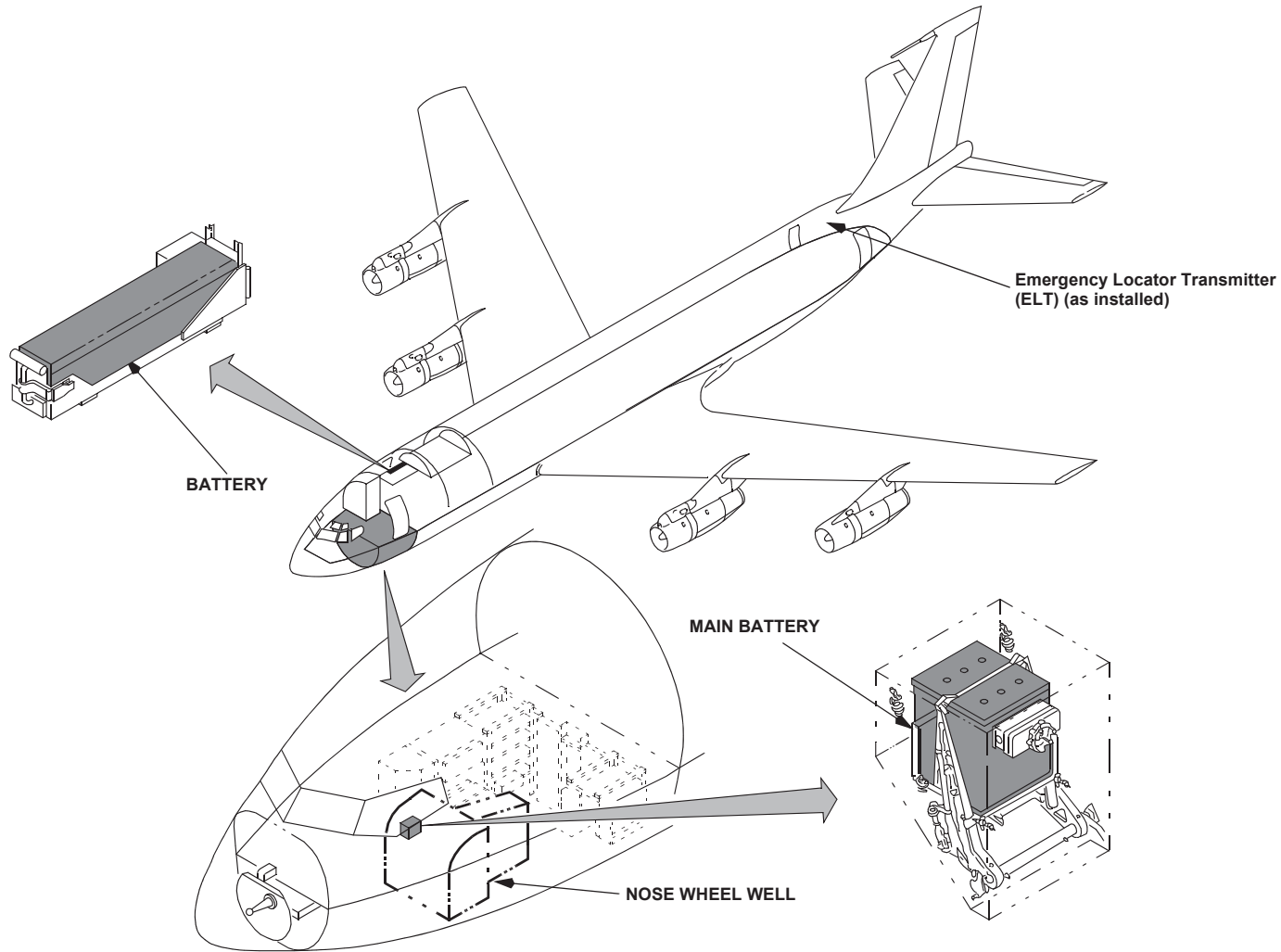

# 720 & 720B SERIES

# FLIGHT DECK CONTROL SWITCH LOCATIONS

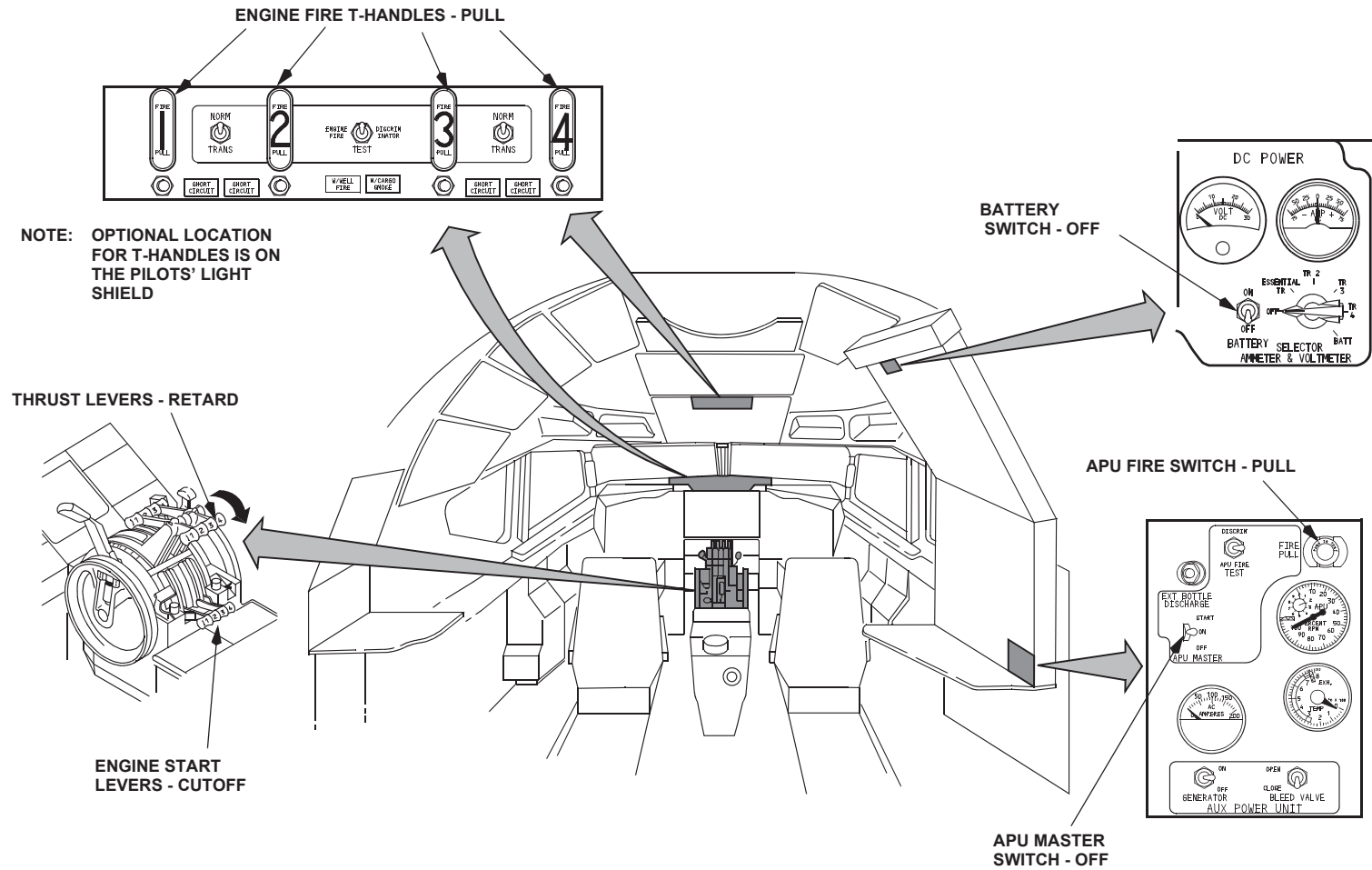

CRITICAL SWITCH LOCATIONS AND THEIR OPERATION ARE SHOWN WITH THE EXPANDED VIEWS OF THE CONTROL MODULES



**720 & 720B SERIES**

**Intentionally Blank**